

Bell Holder w/ Permanent Gasket 40L & 40LBLACK

Features

- Lampholder constructed of weatherproof, corrosion-proof die-cast aluminum. Equipped with a locked-in three part aluminum/silicone rubber/fiberglass "Cushion Seal" lamp gasket.
- High temperature glazed porcelain socket and fully enclosed leads extended for easy splicing.
- Arm is constructed of die-cast aluminum with threaded male end for 1/2" NPT; fully adjustable with degree marked aiming quadrant, serrated gripping teeth and heavy locknut.
- Comes with 1 year limited warranty.

CSA Approved

cUL Listed for Wet Locations



Dimensions

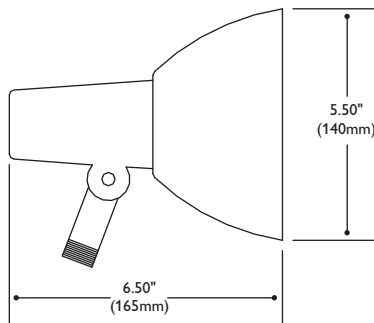

Ordering information

Catalogue Number	Wattage	Finish	Lamp
40L	75-300W	Aluminum	Par 38, R40, QPar 38
40LBLACK	75-300W	Black	Par 38, R40, QPar 38

- Accessory – Guard: Catalogue #207

Job Information

Type:

Job Name:

Cat. No.:

Lamp(s):

Notes: