

BSC2H

The SmartCart®

2 Wheel Heavy Duty Cart

The SmartCart® is a versatile wire management system consisting of 2 wheeled carts, various modular wire racks for carrying spools of wire and wall storage units to organize and store racks with wire when not in use. The SmartCart® wire management system will assist the electrical contractor with wire installations, improves wire storage, and saves time and labor.

Heavy duty carts are rated for 600 lbs. capacity.

The SmartCart® is provided with a 1-year limited warranty.

Features and Benefits

- Order as standard configuration or customize to your needs with various size racks
- Two holders provided for up to 1" conduit benders
- Built-in tray to hold fish tapes and tools
- Handles are pre-dimpled for mounting material tool boxes (MTB and MTX)
- Cart base plate is pre-punched to accommodate mounting of the extension base plate with built-in wire guide
- Spools are easily changed by placing rack on its side, removing hitch pin and shaft, roll-out and roll-in desired new spool
- Motionless vise attached to the back of cart for cutting 1/2", 3/4" and 1" conduit



BSC2H

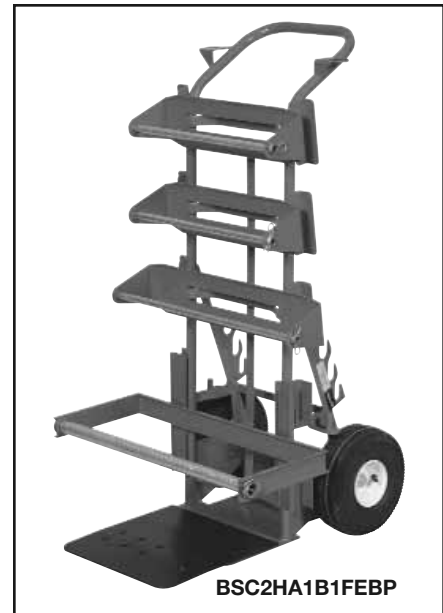

BSC2H2A1B1FEBP

Catalog Number	Description	Weight
BSC2H	2-Wheel Heavy Duty without racks	37 lbs.
BSC2H5A	2-Wheel Heavy Duty with (5) R17A racks	62 lbs.
BSC2H3A2B	2-Wheel Heavy Duty with (3) R17A racks and (2) R22B racks	64 lbs.
BSC2H5B	2-Wheel Heavy Duty with (5) R22B racks	67 lbs.
BSC2H1C2DEBP	2-Wheel Heavy Duty with (1) R17C rack, (2) R25D racks and (1) EBP	86 lbs.
BSC2H2C1DEBP	2-Wheel Heavy Duty with (2) R17C racks, (1) R25D rack and (1) EBP	82 lbs.
BSC2H2A1B1FEBP	2-Wheel Heavy Duty with (2) R17A racks (1) R22B rack (1) R24F rack and (1) EBP	81 lbs.

ACCESSORIES

- EBP** Extension Base Plate with built-in wire guide
- MTB** Material Tool Box
11" L x 6" W x 5" D
- MTX** Material Tool Box (MTB) with Dividers 6-Pockets:
3-5/8" L x 3" W x 3" D
- R17A** 17" wide rack for 7-1/2" diameter spools with 1/2" EMT spindles
- R22B** 22" wide rack for 7-1/2" diameter spools with 1/2" EMT spindles
- R17C*** 17" wide rack for 12" diameter spools with 1" EMT spindles
- R25D*** 25" wide rack for 12" diameter spools with 1" EMT spindles
- R24F*** 24" wide rack for 2-16" diameter reels with 1" EMT spindles
- BSCWS40** 40" Wall Wire Reel Storage System
- BSCWS80** 80" Wall Wire Reel Storage System

*Note: The R17C, R25D, and R24F racks are designed for oversized reels. The Extension Base Plate (EBP) is required when used on The SmartCart®.

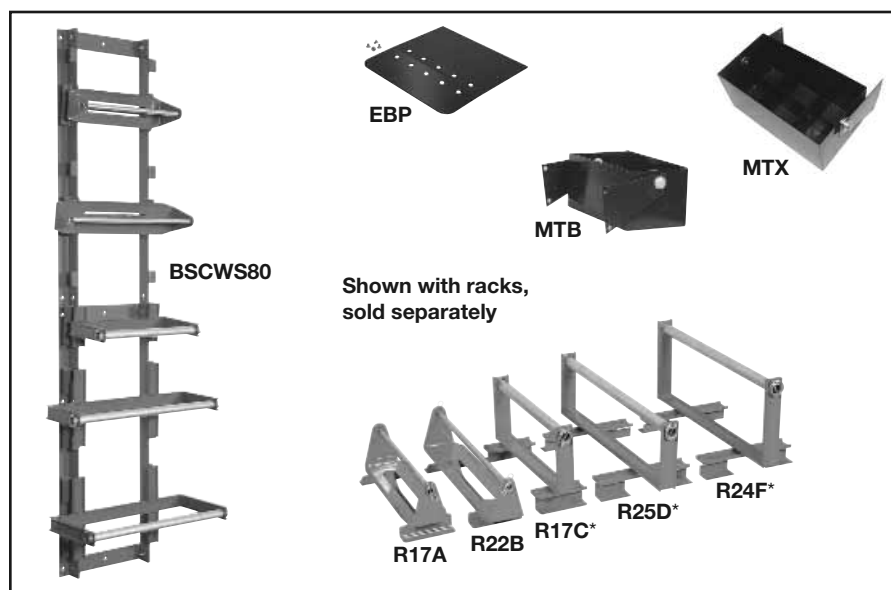

BSC2L

The SmartCart®

2 Wheel Light Duty Cart

The SmartCart® is a versatile wire management system consisting of 2 wheeled carts, various modular wire racks for carrying spools of wire and wall storage units to organize and store racks with wire when not in use. The SmartCart® wire management system will assist the electrical contractor with wire installations, improves wire storage, and saves time and labor.

Light duty carts are rated for 300 lbs capacity.

The SmartCart® is provided with a 1-year limited warranty.

Features and Benefits

- Order as standard configuration or customize to your needs with various size racks
- Two holders provided for up to 1" conduit benders
- Built-in tray to hold fish tapes and tools
- Handles are pre-dimpled for mounting material tool boxes (MTB and MTX)
- Cart base plate is pre-punched to accommodate mounting of the extension base plate with built-in wire guide
- Spools are easily changed by placing rack on its side, removing hitch pin and shaft, roll-out and roll-in desired new spool
- Motionless vise attached to the back of cart for cutting 1/2", 3/4" and 1" conduit



BSC2L

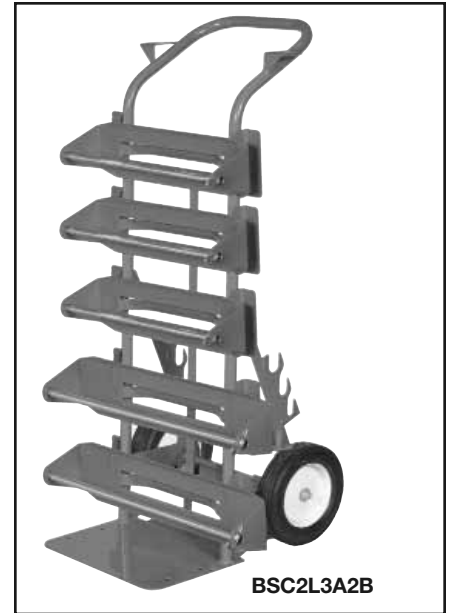

BSC2L3A2B

Catalog Number	Description	Weight
BSC2L	2-Wheel Light Duty without racks	37 lbs.
BSC2L5A	2-Wheel Light Duty with (5) R17A racks	62 lbs.
BSC2L3A2B	2-Wheel Light Duty with (3) R17A racks and (2) R22B racks	64 lbs.
BSC2L5B	2-Wheel Light Duty with (5) R22B racks	67 lbs.
BSC2L1C2DEBP	2-Wheel Light Duty with (1) R17C rack, (2) R25D racks and (1) EBP	86 lbs.
BSC2L2C1DEBP	2-Wheel Light Duty with (2) R17C racks, (1) R25D rack and (1) EBP	82 lbs.

ACCESSORIES

- EBP** Extension Base Plate with built-in wire guide
- MTB** Material Tool Box
11" L x 6" W x 5" D
- MTX** Material Tool Box (MTB) with Dividers 6-Pockets:
3-5/8" L x 3" W x 3" D
- R17A** 17" wide rack for 7-1/2" diameter spools with 1/2" EMT spindles
- R22B** 22" wide rack for 7-1/2" diameter spools with 1/2" EMT spindles
- R17C *** 17" wide rack for 12" diameter spools with 1" EMT spindles
- R25D *** 25" wide rack for 12" diameter spools with 1" EMT spindles
- R24F *** 24" wide rack for 2-16" diameter reels with 1" EMT spindles
- BSCWS40** 40" Wall Wire Reel Storage System
- BSCWS80** 80" Wall Wire Reel Storage System

*Note: The R17C, R25D, and R24F racks are designed for oversized reels. The Extension Base Plate (EBP) is required when used on The SmartCart®.

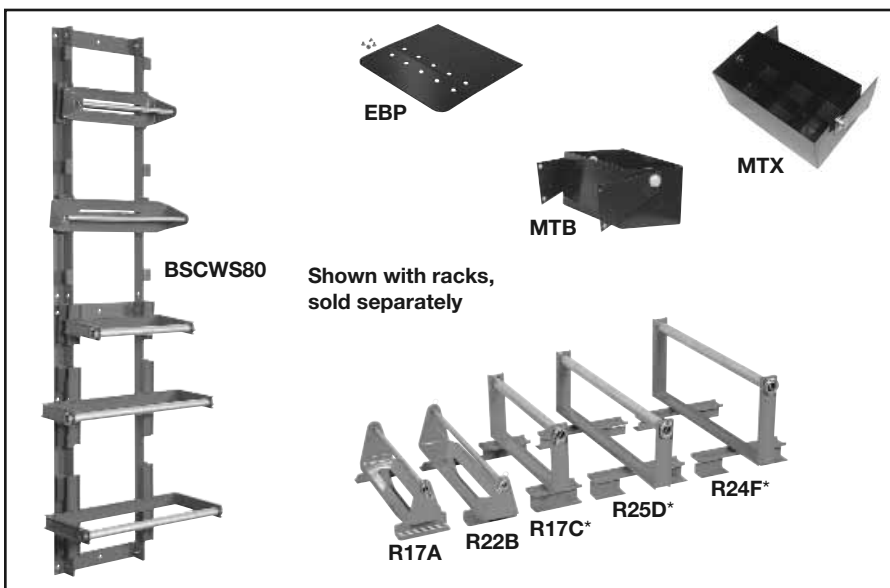

BSCWS80

Shown with racks, sold separately