



HL500Q QUARTZ FLOOD

The HL500Q is a general use security quartz flood. Ideal for use on houses, barns, small commercial properties and cottages. For outdoor use only.

HOUSING Precision die-cast aluminum housing, with a powder coat paint finish.

REFLECTOR Semi-specular anodized aluminum.

LENS FRAME Cast aluminum frame with hinged bottom, held in place by a stainless steel clip.

LENS 5mm thick, tempered glass lens with one piece molded silicone gasket.

LENS GASKET High temperature silicone gasket.

LAMP All units come complete with a 500 watt 120 volt quartz lamp. Lamp packed with protective cushion for easy installation.

ARM Precision die-cast aluminum arm with locking teeth that tighten securely.



SOCKET Double ended porcelain RSC base socket with spring loaded centre contacts.

MOUNTING 1/2" threaded NPS arm with lock nut. Fits all standard mounting plates.

FINISH Standard colours are bronze and white.

www.rabdesign.ca

Catalog Code

HL500Q

BZ - BRONZE

WH - WHITE

FINISH

RAB

DESIGN

LAMP INCLUDED

Dimensions

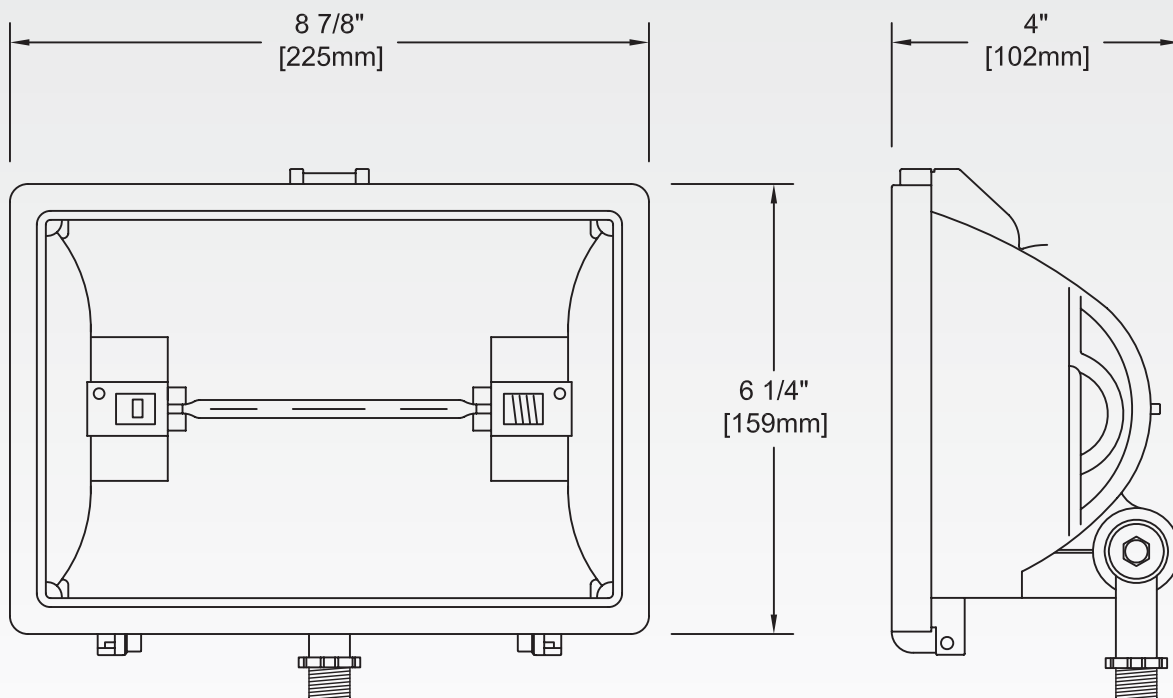

1009

www.rabdesign.ca