



MS-LED-1H-180

LED

The MS-LED-1H-180 has a 180 degree sensor and comes with one LED flood and mounting plate. The MS-LED-1H-180 is equivalent to a 300 watt quartz unit with a total of 1800 lumens out of the fixture. Whenever the motion sensor detects motion the floodlight automatically turn on. The sensor is adjustable and can turn the light on from 5 seconds to 12 minutes. Unit can be wired in parallel. Tested at -40°C start temperature. Available in black or white.

PHOTO ELECTRIC CONTROL

Deactivates lights during daylight. Fully adjustable for 24 hour operation or custom applications.

POWER CONSUMPTION 27 watts.

TIME ADJUSTMENTS 5 seconds to 7 minutes.

LED FLOOD Extruded aluminum with clear lens. Unit has nine LEDs providing 1800 lumens out of the fixture.

MOUNTING PLATE Cast aluminum.

DETECTION 180 degrees.

VOLTAGE 120 volts AC 60 Hertz.



MOUNTING Fits over a standard octagon box.

LUMENS 1800

OPERATING TEMPERATURE -40°C TO 50°C

RATING IP55

WARRANTY 5 year warranty.

cCSAus Approved

Catalog Code

MS-LED-1H-180

BLK - BLACK
WH - WHITE

FINISH

Dimensions

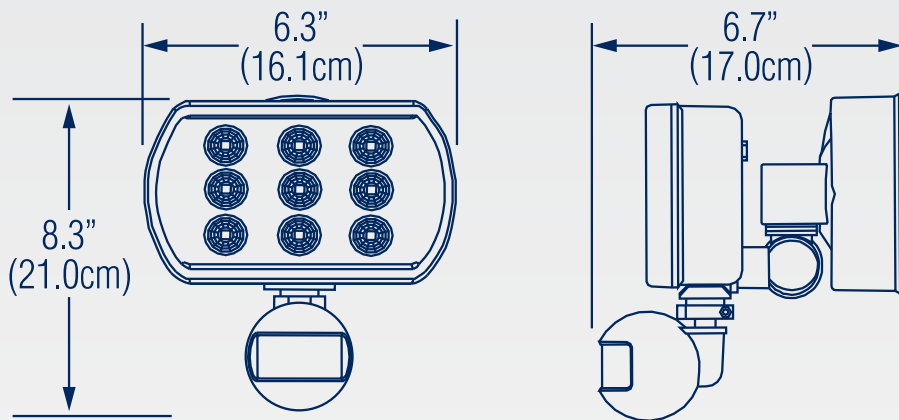

Detection Pattern

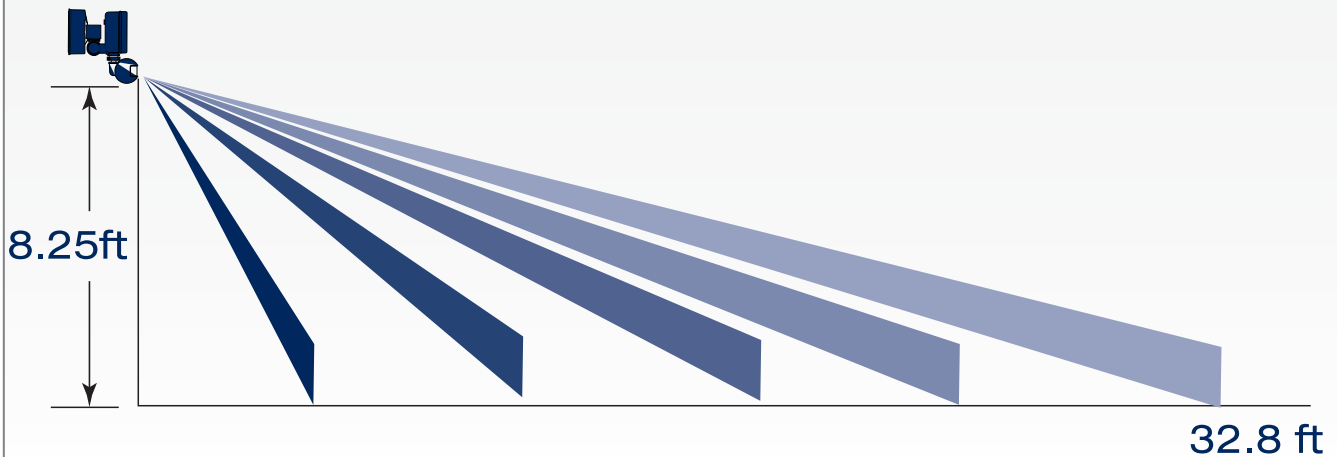

www.rabdesign.ca