

**CONCEPT™ EMC, TYPE 4X**

**INDUSTRY STANDARDS**

Mounting brackets required to meet UL/CSA external mounting requirements.

UL 508A Listed; Type 4, 4X, 12; File No. E61997  
 cUL Listed per CSA C22.2 No 94; Type 4, 4X, 12; File No. E61997

NEMA/EMAC Type 4, 4X, 12, 13  
 CSA File No. 42186: Type 4, 4X, 12  
 VDE IP66  
 IEC 60529, IP66

**APPLICATION**

Use stylish CONCEPT™ EMC Enclosures with their convenient quarter-turn latches in corrosive indoor or outdoor applications to contain stray electromagnetic interference (EMI) signals produced by internal components and to shield those components from external EMI/RFI interference.

**SPECIFICATIONS**

- Manufactured from 18, 16 and 14 gauge Type 304 stainless steel
- Seams continuously welded and ground smooth
- Minimum-width body flange provides maximum body opening
- External formed 90-degree body flange
- Panel mounting studs fit optional CONCEPT panels and other accessories
- Mounting holes in back of body for direct mounting or for optional external mounting brackets
- Stainless steel hidden hinges
- Easy-to-remove clip-style hinge pins
- Removable corner formed door
- Seamless foam-in-place gasket adjacent to spring finger EMC gasket
- Quarter-turn latches with flush slotted insert
- Self-grounding latch system with double seal
- Integral body grounding stud
- Furnished hardware kit includes panel mounting nuts, grounding hardware and sealing washers for wall-mounting holes
- Installation instructions

**FINISH**

Cover and body have smooth brushed #4 finish.

**ACCESSORIES**

See also *Accessories*.

Industrial Corrosion Inhibitors

CONCEPT™ Panels

Handles

Lock Inserts

**BULLETIN: CWSEM**
**Standard Product**

Catalog Number	AxBxC in./mm	Door Gauge	Body Gauge	Panel	Conductive Panel	Panel Size D x E in./mm	Mounting G x H in./mm	Latches Qty.	J in./mm
CSD12126EMCSS	12.00 x 12.00 x 6.00 305 x 305 x 152	16	18	CP1212	CP1212G	10.20 x 10.20 259 x 259	10.50 x 10.50 267 x 267	1	6.00 152
CSD16126EMCSS	16.00 x 12.00 x 6.00 406 x 305 x 152	16	18	CP1612	CP1612G	14.20 x 10.20 361 x 259	14.50 x 10.50 368 x 267	1	8.00 203
CSD16166EMCSS	16.00 x 16.00 x 6.00 406 x 406 x 152	16	18	CP1616	CP1616G	14.20 x 14.20 361 x 361	14.50 x 14.50 368 x 368	1	8.00 203
CSD20166EMCSS	20.00 x 16.00 x 6.00 508 x 406 x 152	16	18	CP2016	CP2016G	18.20 x 14.50 462 x 361	18.50 x 14.50 470 x 368	1	10.00 254
CSD16208EMCSS	16.00 x 20.00 x 8.00 406 x 508 x 203	16	18	CP2016	CP2016G	18.20 x 14.20 462 x 361	14.50 x 18.50 368 x 470	1	8.00 203
CSD24208EMCSS	24.00 x 20.00 x 8.00 610 x 508 x 203	16	18	CP2420	CP2420G	22.20 x 18.20 564 x 462	22.50 x 18.50 572 x 470	1	12.00 305
CSD24248EMCSS	24.00 x 24.00 x 8.00 610 x 610 x 305	14	16	CP2424	CP2424G	22.20 x 22.20 564 x 564	22.50 x 22.50 572 x 572	2	5.00 127
CSD30248EMCSS	30.00 x 24.00 x 8.00 762 x 610 x 203	14	16	CP3024	CP3024G	28.20 x 22.20 716 x 564	28.50 x 22.50 724 x 572	2	5.00 127
CSD36308EMCSS	36.00 x 30.00 x 8.00 914 x 762 x 203	14	16	CP3630	CP3630G	34.20 x 28.20 869 x 716	34.50 x 28.50 876 x 724	2	5.00 127
CSD242412EMCSS	24.00 x 24.00 x 12.00 610 x 610 x 305	14	16	CP2424	CP2424G	22.20 x 22.20 564 x 564	22.50 x 22.50 572 x 572	2	5.00 127
CSD362412EMCSS	36.00 x 24.00 x 12.00 914 x 610 x 305	14	16	CP3624	CP3624G	34.20 x 22.20 869 x 564	34.50 x 22.50 876 x 572	2	5.00 127

Purchase panels separately.

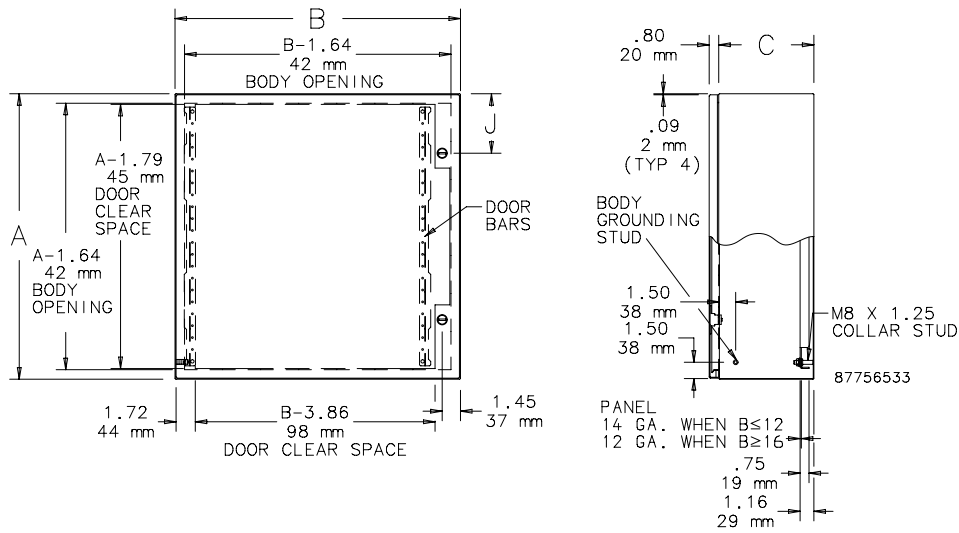

CONCEPT™ Stainless Steel Cabinet Shielding Effectiveness  
CSD20166EMCSS Shielded Cabinet Compared to CSD20166SS Standard Cabinet

