

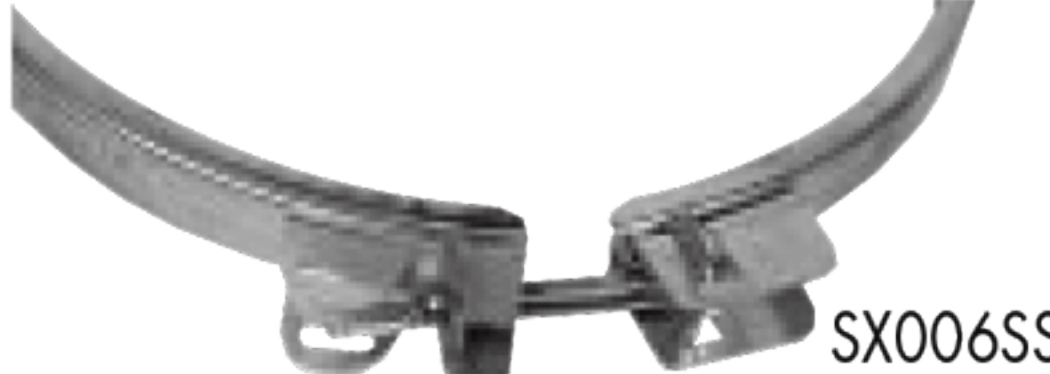



Meter Socket Sealing Rings

CATALOGUE #	DESCRIPTION	WEIGHT	
SX001M	Slip Lock Type	15 lbs./100	 <p>SX001M</p>
SX002M	Latch Type or Buckle Type (Meter Sealing Ring)	17 lbs./100	
SX006M	Adjustable Screw Type - Aluminum	17 lbs./100	
SX006SS	Stainless Steel Screw Type Tamperproof Acrylic (Peerless)	25 lbs./100	 <p>SX006SS</p>
SX008M		25 lbs./100	

Meter Opening Cover Plates

CATALOGUE #	DESCRIPTION	WEIGHT	
SX087MD	Hard Plastic	12 lbs./100	 <p>SX087MD</p>
SX087MC	Clear Lexan	12 lbs./100	
SX087CB	Clear Bladed Lexan	13 lbs./100	
SX025P	Plastic (temporary) - Throw Away	1 lb./100	
SX087S	Steel	1 lb.	
SX087SMC-5	Meter Protector 5" Depth – Entire Front Lifts	3 lbs.	 <p>SX087SMC-1</p> <p>SX087SMC-5</p>
SX087SMC-9	Meter Protector 9" Depth – Entire Front Lifts	5 lbs.	
SX087PG	Meter Puller (Polycarbonate Plastic)	3 lbs.	
SX087SMC-1	Glass Meter Protector 5" Depth Screwless installation	3 lbs.	