

Thermostats

Defender® Explosion-Proof Thermostats

XT-311 and XT-312 Defender® Thermostat

Ruffneck™ Defender® XT-311 and XT-312 explosion-proof heavy-duty thermostats are the smallest, lightest and most durable thermostats available. These thermostats are designed to control heating only, cooling only, or ventilation systems in demanding industrial applications. These include oil refineries, petrochemical plants, pulp and paper mills, coal mines, grain elevators, hazardous waste storage facilities, and other hazardous locations where specific explosive gases or dusts are present.



For hazardous-location temperature controls, rely on Defender® thermostats for the most dependable and trouble-free service available. Ruffneck™ Defender® XT-311 and XT-312 thermostat's unique and highly engineered design offers outstanding features and benefits.

More Features ... More Benefits:

- all-aluminum exterior
- no breakable external plastic parts
- no exposed copper or brass
- corrosion resistant, suitable for H₂S environments
- compact & lightweight
- more competitively priced
- CFC & mercury free
- environmentally safe, no leveling required
- 3-year warranty: longest trouble-free warranty in the industry
- precision die-cast components
- greater consistency, better quality
- bimetal sensing element
- fast-acting, reliable, unaffected by altitude
- no delicate coils or bellows
- rugged reliability
- 480 VAC maximum
- wider range of applications

Specifications

Temperature range: 36°F to 82°F (2°C to 28°C)
Temperature differential: 2.5 F° (1.5 C°)
Net weight: 2.1 lbs (0.95 kg)
Switching: Snap acting
Conduit opening: 3/4" - 14 NPT



Electrical Rating

22 amps Res., 480 VAC Max.;
1/2 HP @ 125 VAC, 1 HP @ 250 VAC

Class I, Divisions 1 & 2, Groups C & D;
Class II, Division 1, Groups E, F, & G;
Class II, Division 2, Groups F & G; Class III;
Class I, Zones 1 & 2, Groups IIA & IIB

Patents

Pat. 08/583,929 USA
Pat. Pending 2,151,641 CAN
Des. Pat. 376,109 USA; Rd. 1996, 78975 CDN

Available in Two Models

XT-311 (Feed-Through, Single Pole, Single Throw)
For heating-only applications.

XT-312 (Feed-Through, Single Pole, Double Throw)
For heating or cooling / ventilation applications.

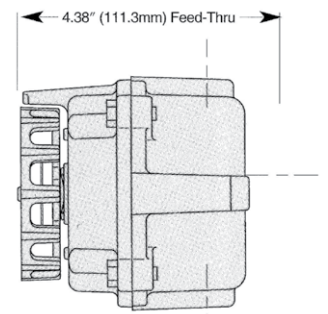
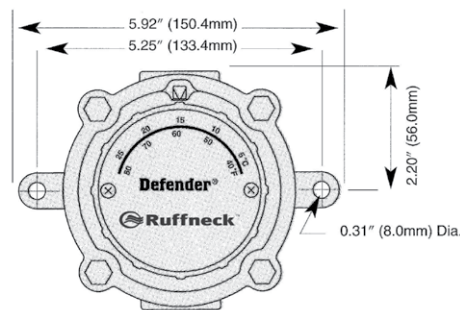

XT-311, XT-312 Defender®