

**Defender®**  
Explosion-Proof Thermostats

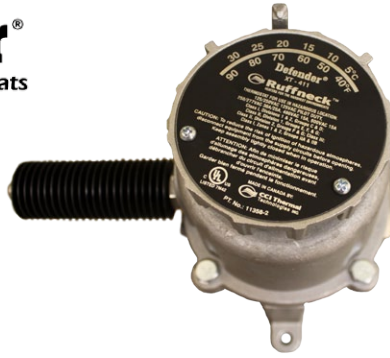

### XT-411 Defender® Thermostat

Ruffneck™ Defender® XT-411 is engineered for use in the most demanding applications such as drilling rigs, utilidors and compression stations where high vibration, dirt, moisture, fluctuating power and high impact conditions exist. It is considered the most robust and trouble-free thermostat in the market due to its solid construction.

The Ruffneck™ Defender® XT-411 thermostat is for heating only and is suitable for ventilation systems in demanding industrial applications. It is designed for use in hazardous locations where specific explosive gases or dusts are present. The Ruffneck™ Defender® XT-411 thermostat is the only available explosion-proof thermostat for line voltage or pilot duty for up to 600 VAC.

### More Features ... More Benefits:

- all aluminum exterior
- no breakable external plastic parts
- no exposed copper or brass
- corrosion resistant, suitable for H2S environments
- CFC & mercury free, no leveling required
- precision die cast components
- sensing bulb is protected by a sturdy thermowell
- suitable for high vibration installations
- suitable for dirty environments and high humidity environments
- impact resistant and will not lose its calibration set-point
- 600 VAC maximum
- compact and light-weight
- comes pre-wired for easy installation
- compatible with all previous and current Defender® thermostat housings
- compatible with all Ruffneck™ FX4 and FX5 heaters

### Specifications

**Temperature range:** 40°F to 90°F (5°C to 30°C)

**Temperature differential:** 6.5°F (3.6°C)

**Net weight:** 3.1 lbs (1.41 kg)

**Switching:** Snap acting

**Conduit opening:** 3/4" - 14 NPT

### Electrical Rating

600 VAC Max. (Canada) / 480 VAC Max. (US);

240V/30A (Canada and US)

480V/15A (Canada and US)

600V/15A (Canada Only)

Class I, Divisions 1 & 2, Groups C & D;  
Class II, Division 1, Groups E, F & G;  
Class II, Division 2, Groups F & G; Class III;  
Class I, Zones 1 & 2, Groups IIA & IIB

### Part Number

XT-411L

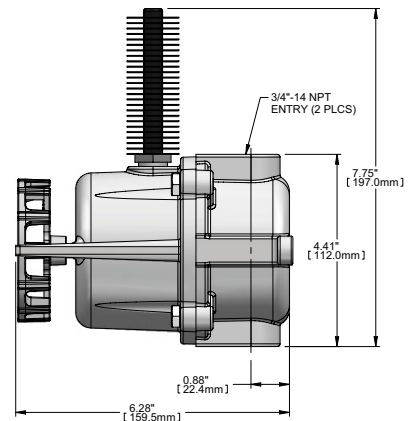
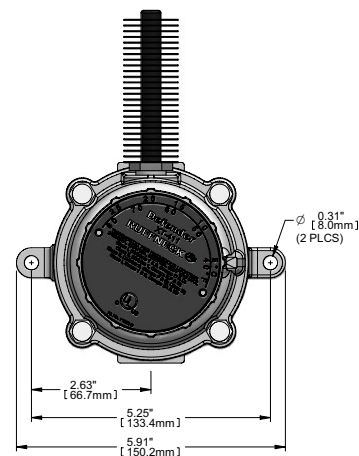

XT-411 Defender®