



# METER CABINETS TYPE 3R

## FEATURES AND BENEFITS

- EEMAC/CEMA Type 3R Enclosure (Weatherproof)
- Gasketed hinged cover c/w padlockable hasps
- Driphood
- White steel backpan
- Wall-mounting ears top and bottom
- Galvanized steel construction
- Industry standard ASA-61 grey industrial powder coat finish



Model #	Description
WMC 27	27"H x 13"W x 10"D Single Door
WMC 30	30"H x 30"W x 10"D Single Door
WMC 36	36"H x 36"W x 12"D Single Door
WMC 48	48"H x 48"W x 12"D Double Door c/w Three Point Lock

# TELEPHONE CABINETS TYPE 3R

## FEATURES AND BENEFITS

- EEMAC/CEMA Type 3R Enclosure (Weatherproof)
- Gasketed hinged cover c/w keyed L-Handle
- Dripshield
- Plywood backpan
- Wall-mounting ears top and bottom
- Mild steel construction
- Industry standard ASA-61 grey industrial powder coat finish



Model #	Description
WPT 18124	18"H x 12"W x 4"D
WPT 18126	18"H x 12"W x 6"D
WPT 24184	24"H x 18"W x 4"D
WPT 24186	24"H x 18"W x 6"D
WPT 24244	24"H x 24"W x 4"D
WPT 24246	24"H x 24"W x 6"D
WPT 36244	36"H x 24"W x 4"D
WPT 36246	36"H x 24"W x 6"D



# SPLITTER BOXES TYPE 3R

## FEATURES AND BENEFITS

- EEMAC/CEMA Type 3R Enclosure (Weatherproof)
- Lift-off cover
- Cu/Al lugging with main and six secondaries
- Designed for pole or wall mounting
- Rural service box
- Galvanized steel construction
- Non-painted finish
- Higher amperage available
- Custom sizes available (consult factory)

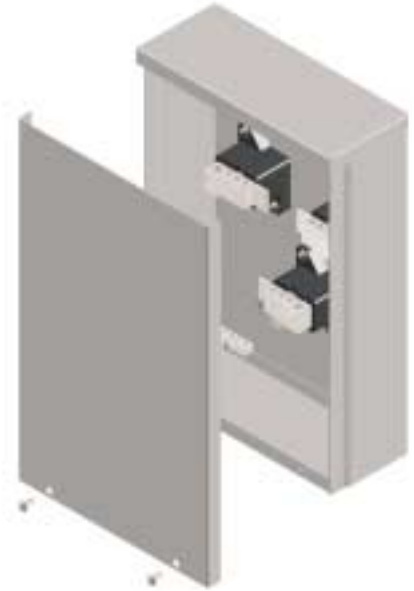

Model #	Amp	Mains	Secondaries	Description
APS 100	125	(1) #14 to 1/0	#14 to #2	14"H x 9"W x 3 1/2"D
APS 100-4W	125	(1) #14 to 1/0	#14 to #2	18 1/4"H x 9"W x 3 1/2"D
APS 200	225	(1) #6 to 300 MCM	#14 to 2/0	14"H x 11"W x 5 1/2"D
APS 200-4W	225	(1) #6 to 300 MCM	#14 to 2/0	18 1/4"H x 11"W x 5 1/2"D
APS 200M	225	(2) #6 to 300 MCM	#14 to 2/0	14"H x 11"W x 5 1/2"D
APS 200-OS	225	(1) #6 to 300 MCM	#14 to 2/0	18 1/4"H x 11"W x 5 1/2"D

## TRAILER SPLITTER BOXES

- same as above except padlockable

Model #	Amp	Mains	Secondaries	Description
APST 125	125	(1) #14 to 1/0	#14 to #2	14"H x 9"W x 3 1/2"D
APST 225	225	(1) #6 to 300 MCM	#14 to 2/0	14"H x 11"W x 5 1/2"D

## ALUMINUM TRAILER SPLITTER BOXES

- same as above except aluminum construction and non-painted finish

Model #	Amp	Mains	Secondaries	Description
APSTA 125	125	(1) #14 to 1/0	#14 to #2	14"H x 9"W x 3 1/2"D
APSTA 225	225	(1) #6 to 300 MCM	#14 to 2/0	14"H x 11"W x 5 1/2"D





# SPLITTER TROUGHS TYPE 3R (3 WIRE)

## FEATURES AND BENEFITS

- EEMAC/CEMA Type 3R Enclosure (Weatherproof)
- Gasketed lift-off cover
- Cu/Al lugging with main and six secondaries
- Wall mounting
- Mild steel construction
- Industry standard ASA-61 grey industrial powder coat finish
- Custom sizes available (consult factory)

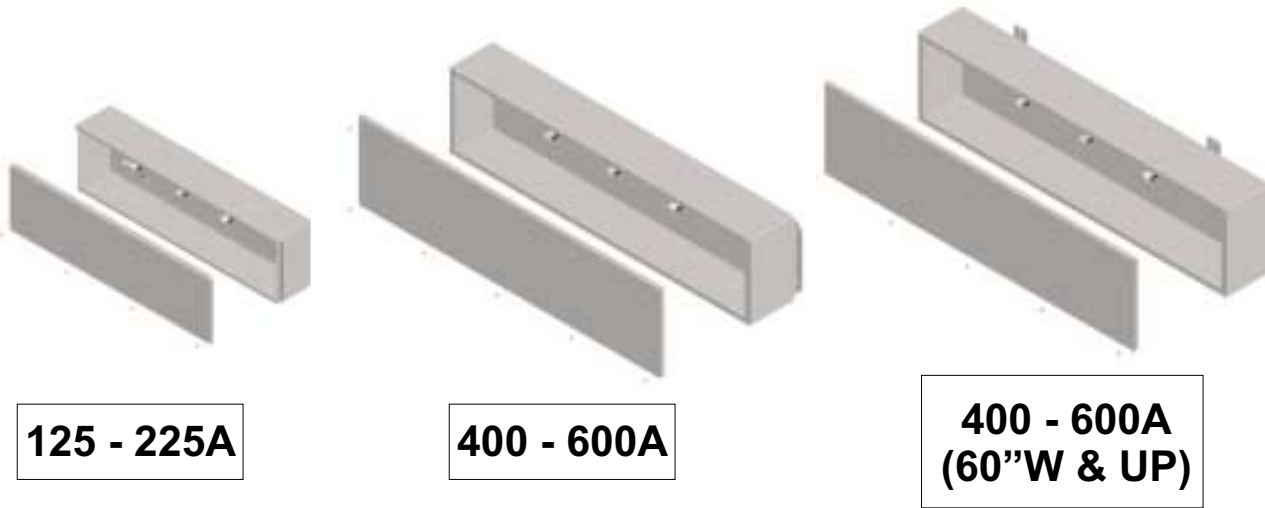

Model #	Amp	Mains	Secondaries	Description
3S-100-24-3W	125	#14 to 1/0	#14 to #2	24"H x 9"W x 6"D
3S-100-36-3W	125	#14 to 1/0	#14 to #2	36"H x 10"W x 6"D
3S-100-48-3W	125	#14 to 1/0	#14 to #2	48"H x 10"W x 6"D
3S-225-24-3W	225	#6 to 300 MCM	#14 to 2/0	24"H x 9"W x 6"D
3S-225-36-3W	225	#6 to 300 MCM	#14 to 2/0	36"H x 10"W x 6"D
3S-225-48-3W	225	#6 to 300 MCM	#14 to 2/0	48"H x 10"W x 6"D
3S-400-24-3W	400	(1) #4 to 600 MCM or (2) 1/0 to 250 MCM	#6 to 3/0	24"H x 10"W x 6"D
3S-400-36-3W	400	(1) #4 to 600 MCM or (2) 1/0 to 250 MCM	#6 to 3/0	36"H x 10"W x 6"D
3S-400-48-3W	400	(1) #4 to 600 MCM or (2) 1/0 to 250 MCM	#6 to 3/0	48"H x 10"W x 6"D
3S-400-60-3W	400	(1) #4 to 600 MCM or (2) 1/0 to 250 MCM	#6 to 3/0	60"H x 10"W x 6"D
3S-400-72-3W	400	(1) #4 to 600 MCM or (2) 1/0 to 250 MCM	#6 to 3/0	72"H x 10"W x 6"D
3S-600-48-3W	600	(2) #6 to 600 MCM	#6 to 3/0	48"H x 12"W x 7"D
3S-600-60-3W	600	(2) #6 to 600 MCM	#6 to 3/0	60"H x 12"W x 7"D

QUALITY IS OUR STRENGTH



# SPLITTER TROUGHS TYPE 3R (4 WIRE)

## FEATURES AND BENEFITS

- EEMAC/CEMA 3R Type Enclosure (Weatherproof)
- Gasketed lift-off cover
- Cu/Al lugging with main and six secondaries
- Wall mounting
- Mild steel construction
- Industry standard ASA-61 grey industrial powder coat finish
- Custom sizes available (consult factory)

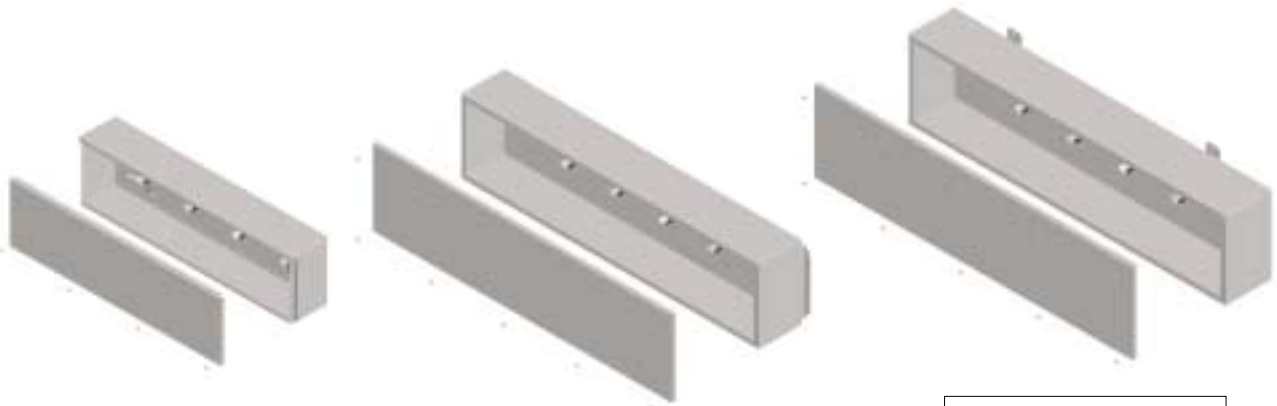

**125 - 225A**

**400 - 600A**

**400 - 600A  
(60"W & UP)**

Model #	Amp	Mains	Secondaries	Description
3S-100-36-4W	125	#14 to 1/0	#14 to #2	36"H x 10"W x 6"D
3S-100-48-4W	125	#14 to 1/0	#14 to #2	48"H x 10"W x 6"D
3S-125-60-4W	125	#14 to 1/0	#14 to #2	60"H x 10"W x 6"D
3S-100-72-4W	125	#14 to 1/0	#14 to #2	72"H x 10"W x 6"D
3S-225-36-4W	225	#14 to 1/0	#6 to 3/0	36"H x 10"W x 6"D
3S-225-48-4W	225	#6 to 300 MCM	#6 to 3/0	48"H x 10"W x 6"D
3S-225-60-4W	225	#6 to 300 MCM	#6 to 3/0	60"H x 10"W x 6"D
3S-225-72-4W	225	#6 to 300 MCM	#6 to 3/0	72"H x 10"W x 6"D
3S-400-48-4W	400	(1) #4 to 600 MCM or (2) 1/0 to 250 MCM	#6 to 3/0	48"H x 10"W x 6"D
3S-400-60-4W	400	(1) #4 to 600 MCM or (2) 1/0 to 250 MCM	#6 to 3/0	60"H x 10"W x 6"D
3S-400-72-4W	400	(1) #4 to 600 MCM or (2) 1/0 to 250 MCM	#6 to 3/0	72"H x 10"W x 6"D
3S-600-48-4W	600	(2) #4 to 600 MCM	#6 to 3/0	48"H x 12"W x 7"D
3S-600-60-4W	600	(2) #4 to 600 MCM	#6 to 3/0	60"H x 12"W x 7"D
3S-600-72-4W	600	(2) #4 to 600 MCM	#6 to 3/0	72"H x 12"W x 7"D