

Specification Submittal Data / Panasonic Ventilation Fan

Description

Ventilating fan shall be low noise ceiling mount type rated for continuous operation. Fan shall be ENERGY STAR rated and certified by the Home Ventilating Institute (HVI). Fan shall include energy efficient compact fluorescent lighting. Evaluated by Underwriters Laboratories and conform to both UL and cUL safety standards.

Motor/Blower:

- Four-pole totally enclosed condenser motor rated for continuous use.
- Power rating shall be 120 volts and 60 Hz.
- Fan shall be UL and cUL listed for tub/shower enclosure when used with a GFCI branch circuit wiring and use in insulated ceiling (TYPE I.C.)
- Motor equipped with thermal-cut-off fuse.
- Permanently lubricated plug-in motor.

Housing:

- Rust proof paint, galvanized steel body.
- Detachable dual 4" or 6" diameter duct adaptor.
- Built in backdraft damper.
- Double hanger bar system allowing for ideal positioning.
- Expandable extension bracket up to 24".

Grille:

- Attractive design using PP material.
- Attaches directly to housing with torsion springs.

Light:

- One 32-Watt compact fluorescent lamp with electronic ballast included.
- One 4-Watt night-light included.
- FCC Part 18 compliant.

Warranty:

3-Year limited warranty. Compact Fluorescent Lamp (CFL): 10,000 hours. No warranty on night-light.

Architectural Specifications:

Ventilation fan shall be ceiling mount, ENERGY STAR rated, with no less than 110 CFM and no more than 0.7 sone at 0.1 static pressure in inches water gauge (w.g.) and no less than 89 CFM and no more than 0.7 sone as certified by HVI at 0.25" w.g. Power consumption shall be no greater than 26.0 Watts at 0.1" w.g. and 25.7 Watts at 0.25" w.g. with energy efficiency of no less than 4.3 CFM/Watt at 0.1" w.g. and 3.5 CFM/Watt at 0.25" w.g. The motor shall be totally enclosed, four pole condenser type engineered to run continuously. Power rating shall be 120v/60Hz. Included is a detachable dual 4" or 6" diameter duct adaptor. Dual motion and humidity sensors with adjustable delay off timer that can be set from 30 seconds to 60 minutes. Humidity sensor is the rapid rise in relative humidity (RH) type with user-adjusted set points between ~30% to ~80% RH. Fan shall be UL and cUL listed for tub/shower enclosure when used with GFCI branch circuit wiring. Fan shall be ASHRAE 62.2, LEED, ENERGY STAR IAP, EarthCraft, California Title-24, WA Ventilation Code and **CALGreen compliant**. Lamps shall utilize no less than one 32-watt energy efficient, compact fluorescent bulb with high efficiency electronic ballast. Night-light feature shall be included.

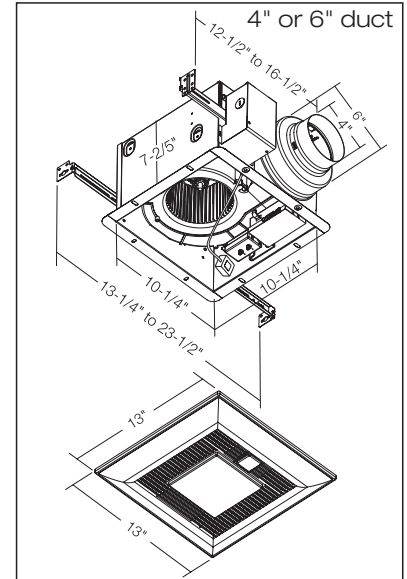

FV-11VQCL5

Specifications: WhisperSense-Lite FV-11VQCL5		4" or 6" Duct (Standard)	
Ventilation Fan Characteristics (HVI tested data)	Static Pressure in inches w.g.	0.1	0.25
	Air Volume (CFM)	110	89
	Noise (sones)	0.7	0.7
	Power Consumption (watts)	26.0	25.7
	Energy Efficiency (CFM/Watt)	4.3	3.5
	Speed (RPM)	1017	1202
	Current (amps)	0.23	0.22
	Power Rating (V/Hz)	120/60	
	ENERGY STAR rated	YES	

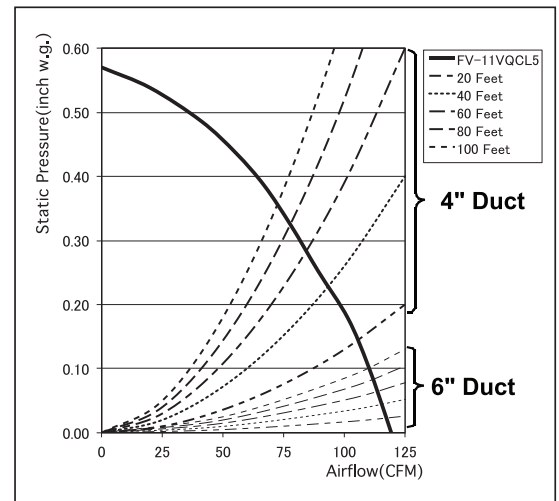

For complete Installation Instructions visit www.panasonic.com/building

Model	Quantity	Comments	Project:
			Location:
			Architect:
			Engineer:
			Contractor:
			Submitted by:
			Date:

Panasonic Home and Environment Company
Division of Panasonic Corporation of North America
One Panasonic Way
Secaucus, NJ 07094

www.panasonic.com/building



Panasonic ideas for life