

ORDERING INFORMATION

Order code: 10036
 Description: BHPS1000/QUADTAP/C/CWA/H/K/STD
 UPC: 69549100367

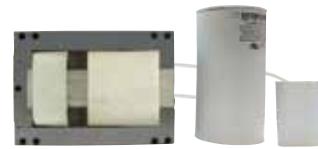

SPECIFICATIONS

Ballast type: Magnetic high pressure sodium
 Ballast style: Core and coil
 Circuit type: CWA
 ANSI code: S52
 Input voltage (V): 120/208/240/277
 Input frequency (Hz): 60
 Line volt regulation: $\pm 10\%$
 Line watt regulation: Within trapezoid
 Insulation class: H (180°)

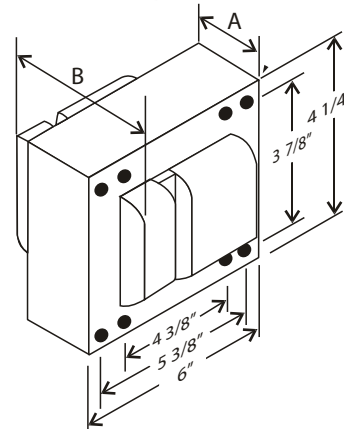

4 1/4" x 6" Core



Input voltage (V)	Operating current (A)	Open circuit current (A)	Starting current (A)	Rated lamp watts (W)	Input watts (W)	OCV (V)	Dropout voltage (V)	UL 1029 code	Fuse rating (A)	Input current (A)	Power factor	Starting temperature
120	9.50	4.81	7.60	1 000	1 100	435	90	D	25	6.00 - 8.00	0.90	-40°F / -40°C
208	5.50	3.00	4.30	1 000	1 100	435	155	C	15	3.40 - 4.70	0.90	-40°F / -40°C
240	4.80	2.60	3.75	1 000	1 100	435	180	D	10	2.90 - 4.00	0.90	-40°F / -40°C
277	4.10	2.20	3.27	1 000	1 100	435	208	D	10	2.5 - 3.45	0.90	-40°F / -40°C

HIGH POTENTIAL TEST (V)

1 minute:	2 000
2 seconds:	2 500
OCV test:	400 - 475
Short circuit:	6.70 - 7.50

BALLAST DIMENSIONS

Dimension A:	3.81"
Dimension B:	6.00"
Lead Lengths:	12.00"
Weight (lbs):	29.00

WIRING DIAGRAM

Ground ballast core

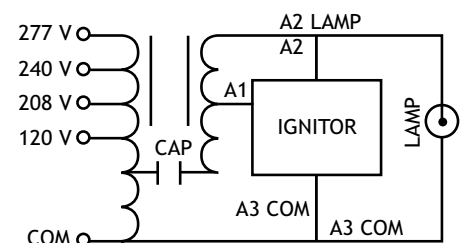

BRACKET

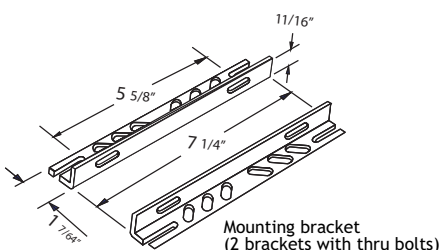

CAPACITOR

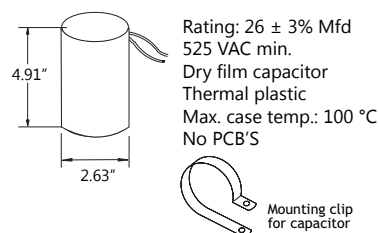

IGNITOR

