



MARCUS

Marcus Transformer LTD
 Phone: 1-800-267-7376
 Fax: 1-866-205-7526
 Email: Info@marcustransformer.com

TECHNICAL DATA MODEL:AMTH 75A1

3-PHASE ISOLATING

DESCRIPTION	
Type	DRY TYPE DISTRIBUTION (ANN)
KVA	75
Primary (Volts)	600
Secondary (Volts)	208Y / 120
Phase	3
Enclosure	NEMA 3R
Impedance (%z)	4.2
Insulation Class	220°C
Temperature Rise	150°C
Frequency	60Hz
Weight (LBS/KG)	550 / 250
Connection	Dyn1
BIL.	10KV
Primary connectors per phase : 1 X 2/0-6	
Secondary connectors per phase: 1 X 350 MCM	

PERFORMANCE	
No load loss	197W
Load loss 100%	1490W
Noise level	50dB

EFFICIENCY			
35%			Efficiency = 98.6% (As per NRCAN 2019 and DOE 2016)

WIRING CONNECTION:

Primary:	H1,H2,H3	
Voltage	% Tap	Jumpers To:
630	105.0	1-1-1
615	102.5	2-2-2
600	100.0	3-3-3
585	97.5	4-4-4
570	95.0	5-5-5

Secondary:		
Voltage	Phase	connect Loads To:
208	3	X1-X2-X3
120	1	X0-X1, X0-X2 and/or X0-X3

VECTOR GROUP:

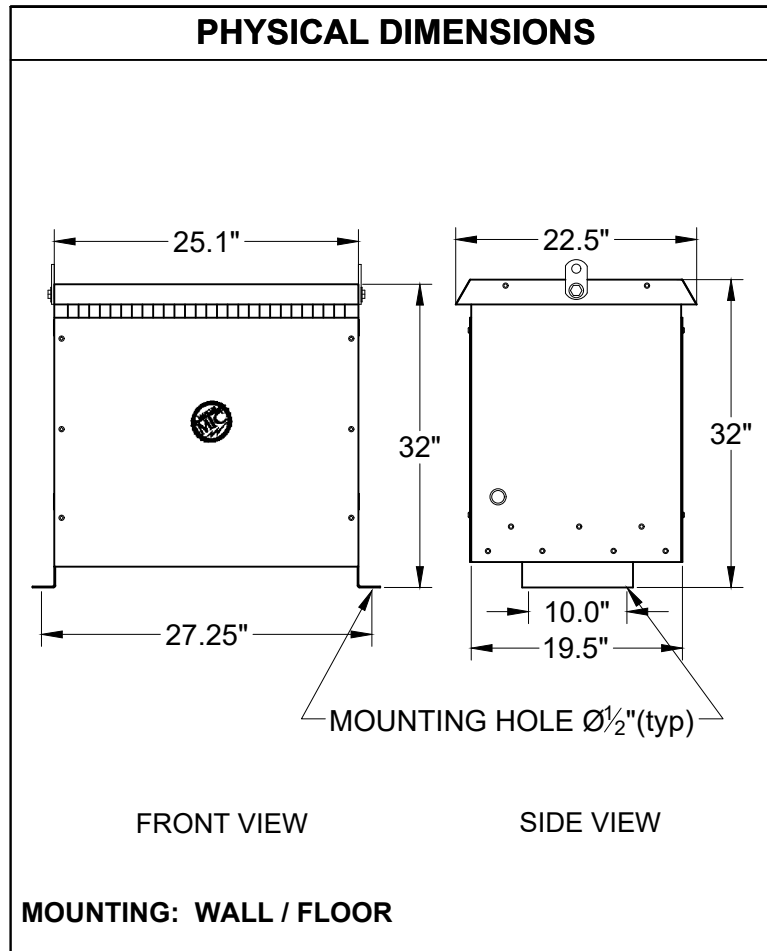
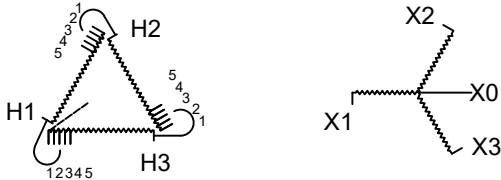

FEATURES:

- Anti-vibration pads installed between the core/coil and the enclosure
- Ground lug provided
- Leads brought-up and solidly positioned into separate terminal boards
- CSA enclosure: ventilated painted ASA 61gray
- Transformer meets the premium efficiency values as per NRCAN 2019/DOE 2016
- Copper ground strap between core/coil and enclosure
- CSA certified
- Aluminium windings

Project	
Engineer	
Revision Date	

COMMENTS