



# MARCUS

Marcus Transformer LTD  
 Phone: 1-800-267-7376  
 Fax: 1-866-205-7526  
 Email: Info@marcustransformer.com

MODEL:AMTH 45A1 **3-PHASE ISOLATING**

## DRAWING FOR APPROVAL

### DESCRIPTION

Type	DRY TYPE DISTRIBUTION (ANN)
KVA	45
Primary (Volts)	600
Secondary (Volts)	208Y / 120
Phase	3
Enclosure	NEMA 3R
Impedance (%Z)	4.8
Insulation Class	220°C
Temperature Rise	150°C
Frequency	60Hz
Weight (LBS/KG)	405 / 184
Connection	Dyn1
BIL.	10KV
Primary connectors per phase : 1 x 2/0-6	
Secondary connectors per phase: 1 x 250 MCM	

### PERFORMANCE

No load loss	106W
Load loss 100%	1272W
Noise level	45dB

### EFFICIENCY

35%			Efficiency = 98.40% (As per NRCAN 2019)

### PHYSICAL DIMENSIONS

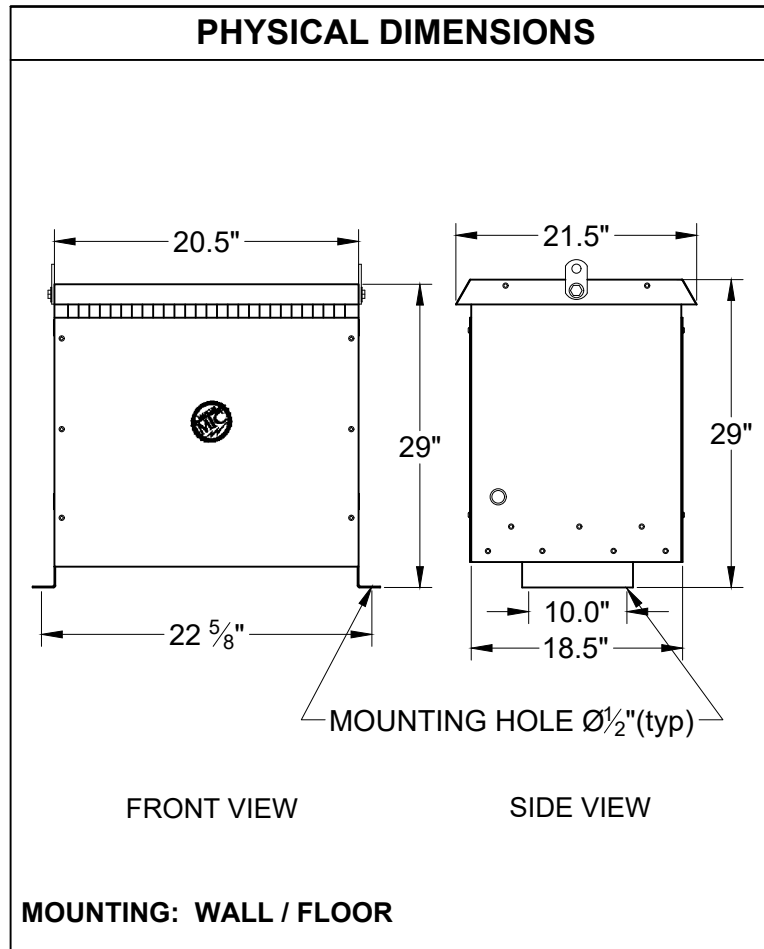

### WIRING CONNECTION:

Primary: H1,H2,H3

Voltage	% Tap	Jumpers To:
630	105.0	1-1-1
615	102.5	2-2-2
600	100.0	3-3-3
585	97.5	4-4-4
570	95.0	5-5-5

Secondary:

Voltage	Phase	connect Loads To:
208	3	X1-X2-X3
120	1	X0-X1, X0-X2 and/or X0-X3

### VECTOR GROUP:

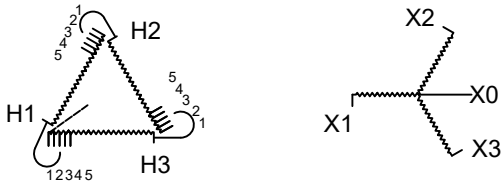

### FEATURES:

- Anti-vibration pads installed between the core/coil and the enclosure
- Ground lug provided
- Leads brought-up and solidly positioned into separate terminal boards
- CSA enclosure: ventilated painted ASA 61gray
- Transformer meets the efficiency values as per NRCAN 2019 / DOE 2016 (File 10 CFR Part 431)
- Copper ground strap between core/coil and enclosure
- CSA certified
- Aluminium windings

Project	
Engineer	
Revision Date	

### COMMENTS

--