

MINIATURE PUSHBUTTONS

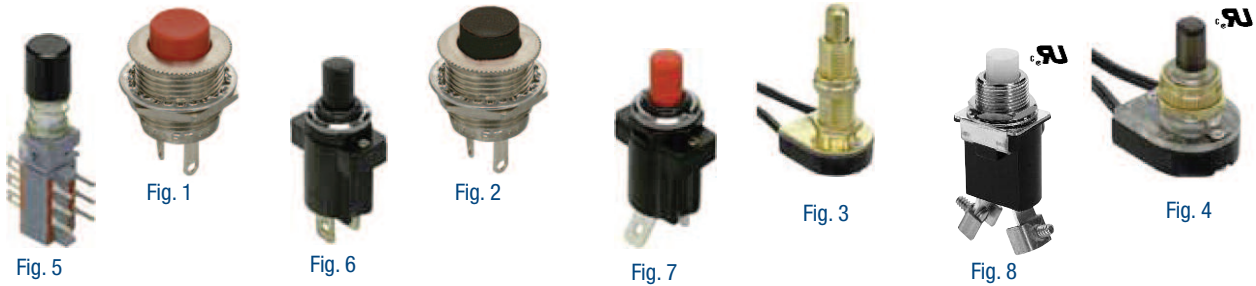

Retail Part No.	Bulk Part No.	Figure No.	Circuit Function	Poles/Throws	AMPS 125VAC	30 Watts	Bushing Length	Actuator Length	Actuator Color	Actuator Style	Terminal Type	Mounting Hole	Hardware	Spec. Drawing Page No.
35-416	35-416-BU	1	On Off	SPDT	N/R	250mA	0.391"	0.110"	Red	RB	Sd Eyelet	0.469"	LN, LW	I-27 A
35-418	35-418-BU	2	On (Off)	SPDT	N/R	250mA	0.391"	0.110"	Black	RB	Sd Eyelet	0.469"	LN, LW	I-27 A
35-3460	35-3460-BU	3	On Off	SPST	6††		1.100"	0.360"	Brass	CB	6" WL	0.375"	N, KN	I-27 B
35-852	35-852-BU	4	On Off	SPST	6††		0.375"	0.344"	Black	CB	6" WL	0.375"	N, KN	I-27 C

Retail Part No.	Bulk Part No.	Figure No.	Circuit Function	Poles/Throws	AMPS 125VAC	Amps 250 VAC	Bushing Length	Actuator Length	Actuator Color	Actuator Style	Terminal Type	Mounting Hole	Hardware	Spec. Drawing Page No.
35-491	35-491-BU	5	On On	DPDT	0.50**	0.20		0.406"	Black	RmB	PCB/Sd Eye		N, LN	I-27 D

Retail Part No.	Bulk Part No.	Figure No.	Circuit Function	Poles/Throws	AMPS 125VAC	30 VAC	Bushing Length	Actuator Length	Actuator Color	Actuator Style	Terminal Type	Mounting Hole	Hardware	Spec. Drawing Page No.
35-475	35-475-BU	6	(On) Off	NO SPST	0.50	0.50	0.260"	0.500"	Red	RB	†††	0.500"	N, LN	I-27 E
35-476	35-476-BU	7	Off (On)	NO SPST	0.50		0.260"	0.500"	Black	RB	†††	0.500"	N, LN	I-27 E
35-3471	35-3471-BU	8	On (Off)	NO SPST	***		0.374"	0.244"	White	RB	Sc	0.500"	N, LW	I-27 F

Notes: (On)/(Off) = Momentary On/Off
 **Rated @100VAC
 ***Rated 2Amps @120VAC, 1A 277 VAC

†† = 3@250V AC
 ††† = 6.3mm Tab w/Eyelet
 35-491 is momentary on if the pin is removed
 CB = Canopy Button
 KN = Knurled Nut
 LN = Lock Nut

LW = Lock Washer
 N = Nut(s)
 NC = Normally Closed
 NO = Normally Open
 N/R = Not Rated

PCB = Printed Circuit Board
 RB = Round Button
 RmB = Removable Button

Sc = Screw
 Sd = Solder

STANDARD PUSHBUTTONS

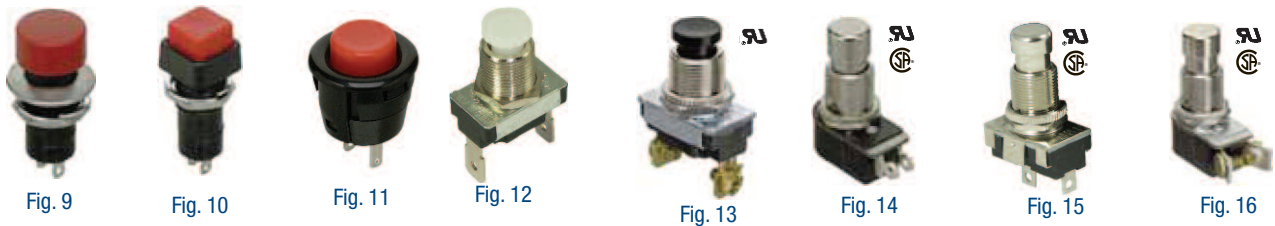

Retail Part No.	Bulk Part No.	Figure No.	Circuit Function	Poles/Throws	AMPS 125VAC	Amps 250 VAC	Bushing Length	Actuator Length	Actuator Color/Material	Frame/Bezel	Terminal Type	Mount Hole	Hardware	Spec. Drawing Page No.
35-420	35-420-BU	9	Off (On)	NO SPST		3	0.276"	0.354"	Red Plastic	Chrm. Ring	Sd Eyelet	0.500"	N, W	I-27 G
35-421	35-421-BU	10	Off (On)	NO SPST		3	0.390"	0.244"	Red Plastic	Black Square	Sd Eyelet	0.500"	N, W	I-27 H
35-422	35-422-BU	9	On Off	SPST		3	0.276"	0.354"	White Plastic	Chrm. Ring	Sd Eyelet	0.500"	N, W	I-27 G
35-423	35-423-BU	11	Off (On)	NO SPST	3	N/R	Snap-in	0.125"	Red Plastic	Black	Sd Eyelet	0.687"		I-27 I
35-3456	35-3456-BU	12	(On) Off	SPST	6	3	0.500"	0.212"	White		Q.C.	0.500"	N, KN	I-27 J
35-3457	35-3457-BU	13	Off (On)	NO SPST	6**	3**	0.500"	0.212"	Black Plastic		Sc	0.500"	N, KN, Sc	I-27 J
35-3458	35-3458-BU	13	(Off) On	NC SPST	***	***	0.490"	0.200"	Red Plastic		Sc	0.500"	N, KN, Sc	I-27 K
35-430	35-430-BU	14	Off (On)	NO SPST	6	3	0.562"	0.437"	Chrm. Metal		Sd Eyelet	0.500"	N, KN	I-27 L
35-432	35-432-BU	14	On (Off)	NC SPST	6	3	0.562"	0.437"	Chrm. Metal		Sd Eyelet	0.500"	N, KN	I-27 L
35-448	35-448-BU	15	On Off	SPST	6	3	0.561"	0.415"	Chrm. Metal		Sd Eyelet	0.500"	N, KN	I-27 L
35-449	35-449-BU	16	On Off	SPST	6	3	0.561"	0.437"	Chrm. Metal		Sc	0.500"	N, KN	I-27 M

Notes: (On)/(Off)/(SPDT) = Momentary Action
 *Rated 8Amps @125V DC, 4Amps @250V DC, 1/3 HP @125VAC;
 **Rated 6Amps @120VAC/3Amps @240VAC
 ***Rated 3Amps @120VAC/1.5Amps @277VAC
 ****Rated 25/15Amps @6/12VDC

† = Rated 1/2 HP @250VDC
 Chrm. = Chrome
 KN = Knurled Nut
 N = Nut(s)

NC = Normally Closed
 NO = Normally Open
 N/R = Not Rated
 QC = Quick Connect
 Sc = Screw

Sd = Solder
 W = Washer
 WL = Wire Lead

Note: All figures are for illustration purpose only, and the number/type of terminals may vary.

All quantities are single; BU's are packages of 25 Unless otherwise noted.

MINIATURE PUSHBUTTONS (Cont.)

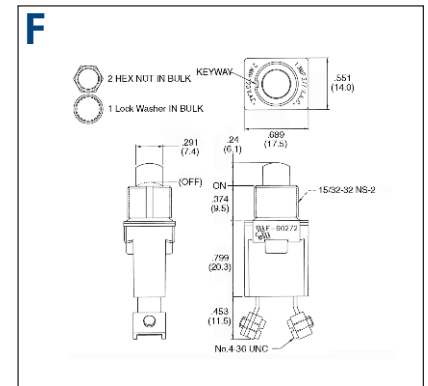
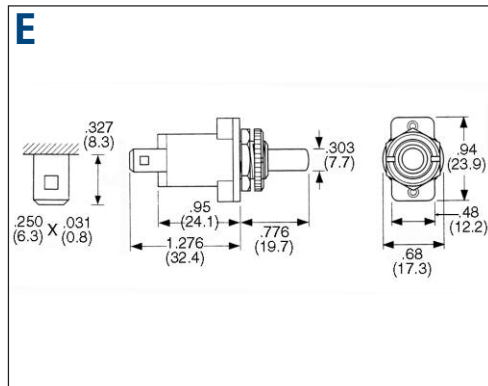
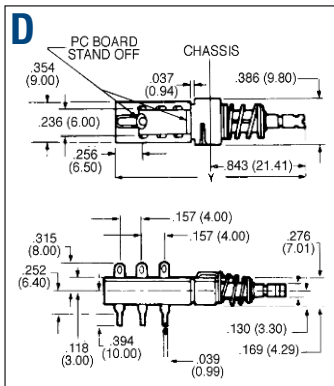
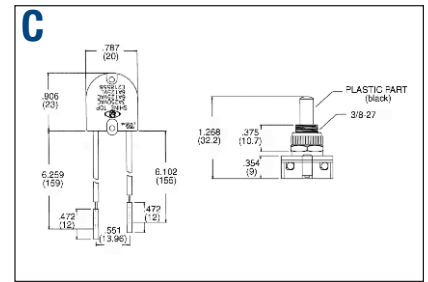
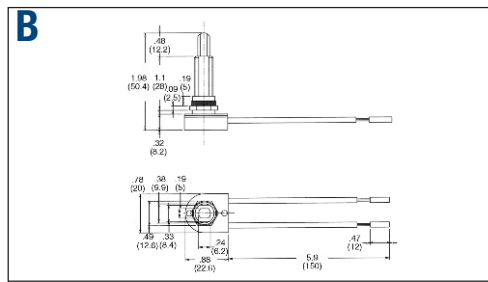
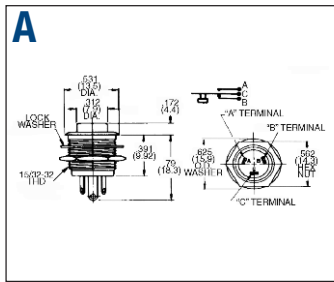

STANDARD PUSHBUTTONS (Cont.)

