

IPL Series

IP65 Linear Fluorescent Fixture

| |
|-------------------|
| Project/Location: |
| Contractor: |
| Date: |
| Prepared by: |
| Lumacell Model: |

FEATURES

- IP65 rated
- Polycarbonate enclosure and lens, vandal resistant and UV stabilized
- Rust-proof hardware
- Ceiling, surface or pendant mounting
- Low profile, less than 4 inch deep
- Ultra efficient specular reflector with optimized shape
- 32W T8 or 54W T5HO
- 90 minutes of emergency operation when installed with our RSFSP or AM inverters
- Emergency operation from external low voltage DC power source when installed with our RSF Series inverters
- Certified for AC or DC, 120V operation
- High efficiency and reliable electronic ballast, instant start or 3-step programmed rapid start
- 120VAC to 277VAC universal and 347VAC input voltage available
- CSA certified to CAN/CSA-E60598-1:02
- Certified for wet and Damp locations



DIMENSIONS

Dimensions are approximate and subject to change.

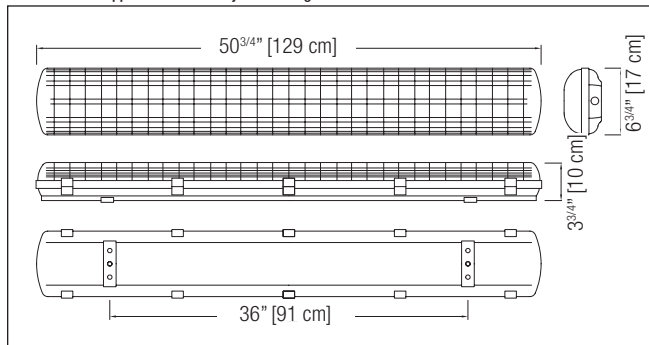

TYPICAL SPECIFICATIONS

Supply and install **Lumacell® IPL Series** of fluorescent fixtures as specified. The luminaire shall operate from 120VAC to 277VAC and use high quality instant start or 3-step programmed rapid start high efficiency electronic ballasts.

The housing and lens shall be constructed of UV- stabilized industrial grade vandal-resistant polycarbonate. A durable formed gasket shall be provided between the enclosure and the lens and shall be designed specifically for hostile environments. The reflector shall be made of highly specular material and formed to maximize light output efficiency. All parts shall be corrosion resistant. A metal plate used to retain the ballast and reflector also serves to dissipate heat, therefore lengthening ballast life.

Lamps shall be as specified, either T8 or T5 HO linear fluorescent lamps, 32W or 54W. The lamps shall not be supplied with the luminaire. Models with an inverter from the RSFSP/AM series and illuminate one or two lamps during emergency operation for at least 90 minutes upon AC failure. During power outage, dual voltage source (AC/DC) models with an inverter from RSF series, shall illuminate one lamp while the DC voltage is present.

The fixture shall be CSA approved and meet IP65 requirements.

Emergency fixture shall have one year warranty.

Non-emergency fixture shall have five year warranty

The inverters of RSF Series shall be CSA approved.

The inverters of RSFSP/AM Series shall be CSA or cUL approved.

The fixture shall be **Lumacell®** model: _____ .

WIRE GUARDS

| | |
|------------|-----------------------------|
| 460.0105-L | Wall Mount or Ceiling Mount |
|------------|-----------------------------|

POWER CONSUMPTION

| MODEL | | AC SPECS | |
|-------|------------|-------------|----------|
| IPL8 | 120/277VAC | 0.54/0.23A | PF > 0.9 |
| IPL83 | 347VAC | 0.19A | PF > 0.9 |
| IPL5 | 120/277VAC | 1.03/0.143A | PF > 0.9 |
| IPL53 | 347VAC | 0.35A | PF > 0.9 |

ORDERING INFORMATION

| SERIES | LAMP TYPE | AC VOLTAGE | ACCESSORIES |
|--|--|---|---|
| IPL= 48" (122cm) linear fluorescent | 8= 2x lamps 32W T8 5= 2x lamps 54W T5HO | Blank= AC only 120/277VAC 3= AC only 347VAC DC= 120/277VAC/VDC | Blank= no accessories Self-Powered, one lamp emergency AM32-L= inverter for IPL8 (complete code= IPL8AM32-L) RSFSP/U/1100= inverter for IPL83 (complete code= IPL8RSFSP/U/1100) AM12= inverter for IPL5 (complete code= IPL5AM12) |
| | Lamps not included Consult your sales representative for DC operation. | | Self-Powered, two lamps emergency AM7= inverter for IPL8 (complete code= IPL8AM7) RSFSP/U/1100= inverter for IPL83 (complete code= IPL8-3 RSFSP/U/1100) Two lamps model not available for T5 bulb (IPL5) AC/DC option, using a remote battery, one lamp only in emergency mode: RSF3200= 6V, 120VAC RSF3200ZD= 6V, 347VAC RSF123200= 12V, 120VAC RSF123200ZD= 12V, 347VAC RSF243200= 24V, 120VAC RSF243200ZD= 24V, 347VAC RSF323200= 32V, 120VAC RSF323200ZD= 32V, 347VAC RSF483200= 48V, 120VAC RSF483200ZD= 48V, 347VAC RSF1203200= 120V, 120VAC RSF2103200ZD= 120V, 347VAC |

EXAMPLE: IPL8