



Provider™ Series

6 Volts Compact Battery Unit
with Laser Option

High performance in a contemporary, compact decorator design

The **Provider™ Series** battery unit combines a sleek, low profile body design and transparent light shield with a complete package of high performance features and options. For the utmost in protection, add the Ruby laser option to point the way to safety. The **Provider™** is ideally suited for any commercial application requiring high performance in an attractive, modern package.

Features

- Injection-molded, impact-, scratch- and corrosion-resistant thermoplastic white housing (also available in black)
- Compact and versatile – unit measures only 11" x 5" and can be wall or ceiling mounted
- Fast and easy installation – AC quick connect plug, battery lockout feature and snap together design
- Tool less aiming and adjustment of lighting heads
- Maintenance-free, long-life sealed lead calcium battery
- 120/347Vac standard input
- Fully automatic, solid-state Pulse-Guard charger with low voltage battery disconnect, brownout protection, integral test switch and long-life LED AC-On pilot lights
- Charger is temperature compensated and reverse polarity protected
- Also available as a remote fixture; see Remote Fixtures section of this catalogue
- CSA C22.2 No. 141 certified





Project/Location:

Date:

Contractor:

Prepared by:

Provider™ Series

C A PM I LS

Typical Specification

The contractor will install the Emergi-lite **Provider™** battery unit. The emergency lighting system shall consist of fully automatic equipment with two (2) emergency lighting heads. The emergency lighting heads shall require no tools for adjusting or aiming. Each unit shall contain a fully automatic, solid-state charger with test switch and AC-on pilot lights. The unit shall contain a sealed transfer circuit and low-voltage disconnect circuit. The battery unit may come with laser option designed to guide

patrons through the path of egress. The battery shall be 6 volts with capacity of ___ watts for 30 minutes.

The unit shall be CSA C22.2 no 141.

The unit shall be Emergi-lite Model - _____.

Dimensions

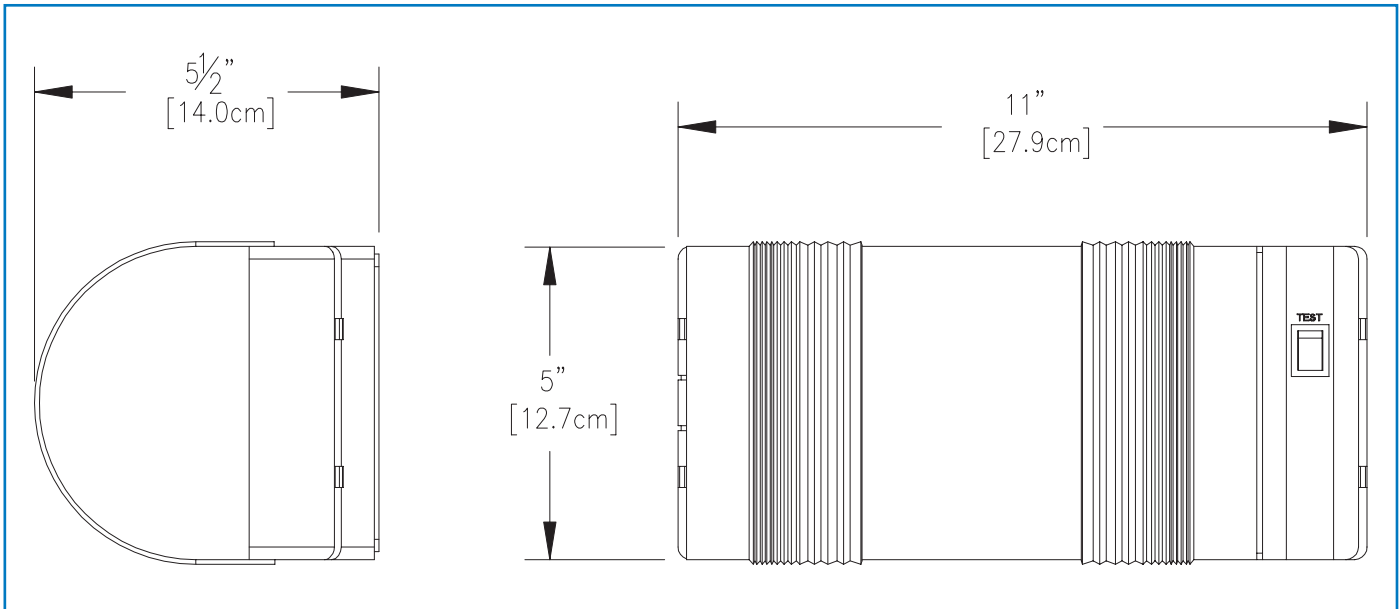

Ordering Information

Series	Special Options	Input Voltage	Colour	Options
CPRO-1= 6V, 18 watts	Blank= standard	Blank= 120/347Vac	Blank= factory white	-AD= auto-diagnostic
CPRO-2= 6V, 36 watts	VM= voltmeter	L= 120Vac c/w line cord	BK= black	-ADNA= auto-diagnostic, non-audible
	VR= vandal-resistant screws	Line cord kit supplied but not installed.		-LZ= laser

EXAMPLE: CPRO-2-L-LZ