

SLED5N RCL

Square LED Step Lights. Equivalent to 13 Watt CFL or 40 Watt incandescent. Applications for steps, decks, landscape and entries. Meets ADA requirements. 5 Year warranty.

Color: Bronze

Weight: 1.5 lbs

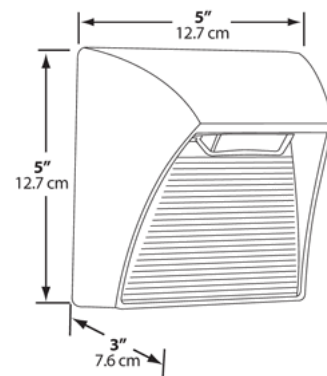

LED Info

Watts: 5W
 Color Temp: 4000K (Neutral)
 Color Accuracy: 85
 L70 Lifespan: 100000
 LM79 Lumens: 155
 Efficacy: 30 LPW

Driver Info

Type: Constant Current
 120V: 0.1A
 208V: 0.06A
 240V: 0.05A
 277V: N/A
 Input Watts: 5W
 Efficiency: 96%

Technical Specifications

cUL Listing:

Suitable for wet locations. Suitable for mounting within 4ft. of the ground.

Lifespan:

100,000-hour LED lifespan based on IES LM-80 results and TM-21 calculations.

Voltage:

100V - 240V.

Finish:

Our environmentally friendly polyester powder coatings are formulated for high-durability and long-lasting color, and contains no VOC or toxic heavy metals.

Driver:

4W high output long life LED. Driver Constant Current, Class 2, 50-60 Hz, 100-240 VAC 0.18 amps.

Thermal Management:

Integral cast aluminum mounting pad for optimum heat sinking to ensure cool operation with maximum LED life and light output.

Cold Weather Starting:

The minimum starting temperature is -40°F/-40°C.

Ambient Temperature:

Suitable for use in 40°C (104°F) ambient temperatures.

Green Technology:

Mercury, Arsenic and UV free.

Color Consistency:

3-step MacAdam Ellipse binning to achieve consistent fixture-to-fixture color.

Lumen Maintenance:

The LED will deliver 70% of its initial lumens at 100,000 hours of operation.

Housing:

Precision die cast aluminum housing and mounting plate (junction box not included).

Surge Protection:

1000 Volts.

IESNA LM-79 & IESNA LM-80 Testing:

RC LED luminaires have been tested by an independent laboratory in accordance with IESNA LM-79 and 80, and have received the Department of Energy "Lighting Facts" label.

Gasket:

High temperature silicone.

Color Temperature (Nominal CCT):

4000K

Equivalency:

The SLED5 is Equivalent in delivered lumens to a 13W CFL or 60W incandescent step light.

HID Replacement Range:

The SLED5 can be used to replace 13-26W CFL or 13-60W incandescent step lights based on delivered lumens.

Patents:

The design of the SLED Lights are protected by U.S. Pat. 612,975, Canada Pat. 133101, and China Pat. ZL201030129140.1.

SLED5N RCL - continued

GSA Schedule:

This product is suitable for listing on the GSA Schedule of the US General Services in accordance with FAR Subpart 25.4.



Tech Help Line: 888 722-1000

Email: sales@rclighting.ca

On the web at: www.rclighting.ca