

ORDERING INFORMATION

Order code: 62921
 Description: BHPS0150/120/C/R/K/STD
 UPC: 69549629219

SPECIFICATIONS

Ballast type: Magnetic high pressure sodium
 Ballast style: Core and coil
 Circuit type: R-NPF/R-HPF
 ANSI code: S55
 Input voltage (V): 120
 Input frequency (Hz): 60
 Line volt regulation: 5 %
 Line watt regulation: Within trapezoid
 Insulation class: H (180)

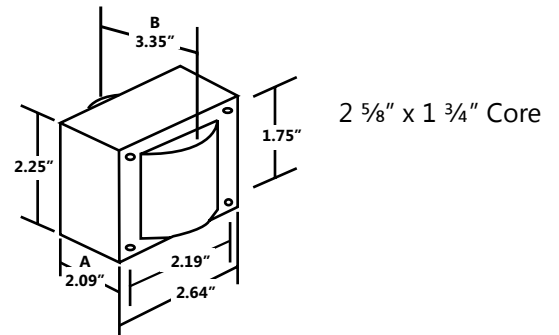

	Input voltage (V)	Operating current (A)	Open circuit current (A)	Starting current (A)	Rated lamp watts (W)	Input watts (W)	OCV (V)	Dropout voltage (V)	UL 1029 code	Fuse rating (A)	Input current (A)	Power factor	Starting temperature
NPF	120	3.12	S.O.	4.30	150	170	120	86	A	8	3.65 - 5.55	0.45	-40°F / -40°C
HPF	120	1.43	2.50	1.94	150	170	120	86	A	5	1.65 - 2.75	0.90	-40°F / -40°C

HIGH POTENTIAL TEST (V)

1 minute:	2 000
2 seconds:	2 500
OCV test:	114 - 126
Short circuit:	3.65 - 5.55

BALLAST DIMENSIONS

Dimension A:	2.09"
Dimension B:	3.35"
Lead lengths:	12" - 14"
Weight (lbs) :	3.31

WIRING DIAGRAM

Ground ballast core

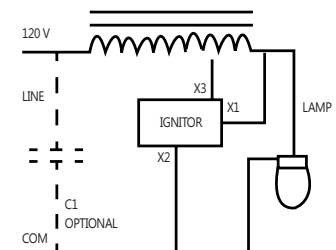

BRACKET

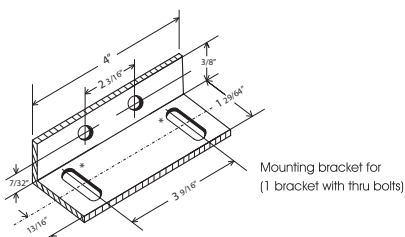

IGNITOR

