

HWB-DIM-EDC-24V-25W

25W Dimmable Electronic LED Hardwire Box, 24V Cabinet, Cove & Display

Job Information		
Project Name		Type
Location		
Quantity		Date
Contact/Phone		
Notes		

Features

Construction

Black painted aluminum enclosure with mounting tabs. IP20 rated for indoor use. Six 7/8" knockouts to enable easy installation that complies with electrical code requirements.

AC Input Details

- Voltage range: 100-130V
- Current: 0.5A
- Frequency range: 50/60Hz
- No load power consumption: <2W
- Leakage current: 0.70mA/110VAC

DC Output Details

- Voltage: 24V
- Current: 1.05A
- Working efficiency: 83%

Environmental Requirements

-40°C~50°C (-40°F~122°F)

Circuit Protection

Open and short circuit protection. Auto-reset functionality automatically reset

once the condition is resolved.

Dimming

Compatible with forward phase, ELV and TRIAC dimmers. See page 2 for compatible dimmers.

Connectivity

18AWG input/output leads. Input side equipped with push-in connectors, while output side is equipped with bloc connector.

Compatibility

Compatible with all DazzLED 24 volt LED lighting fixtures.

Approvals

- Class 2
- cETLus Listed

SPECIFICATIONS	
Application	Undercabinet
Approved Location	Dry / Damp
Certification	cETLus
Classification	Class II
Colour1	BK
Dimming	Yes
Dimming Tech.	Forward phase / ELV / TRIAC
Frequency	50/60 Hz
Input Current	0.5A
Link Connector	Hard Wire
Max. Op. Temp. °C	50°C (122°F)
Min. Start Temp. °C	-40°C (-40°F)
Output Current	1.05A
Power Factor	0.65 @ full load
Power Supply Type	Constant Voltage
Primary Voltage	100-130V AC
Secondary Voltage	24V DC
Warranty	5 Years
Wattage	25W



Description

The HWB-DIM-EDC-24V-25W is a 25W dimmable electronic LED hardwire box. All enclosed in a coated aluminum box that includes 6 knockouts to enable easy installation.

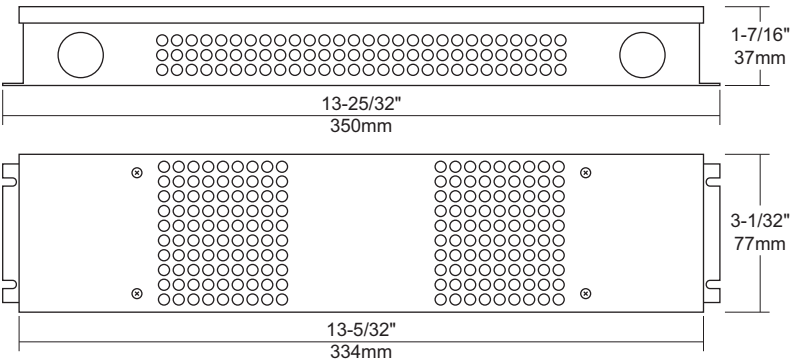

Notes: Accessories should be ordered separately. For additional options please consult your Liteline representative. Due to our continued efforts to improve our products, product specifications are subject to change without notice.

Ordering Guide

- HWB-DIM-EDC-24V-25W**
25W dimmable class 2 power supply, 24V.

Compatible Dimmers

Brand	Series
Lutron®	SCL-153PR
	DVCL-153PR
	DVWCL-153PH
	CTCL-153PDH
	TGCL-153PR
	TGCL-153PH
	MACL-153MH
	CT-600PR
	CT-603PGH
	CT-103PR
	DV-600PR
	DVW-603PGH
	TG-600PR
	TG-10PR
	S-600PR
Leviton®	VPI06-1LZ
	TTI06-1LZ
	IPL06
	6672
	TBL03
	6602
6683	

Wiring Diagrams for Triac Dimmers

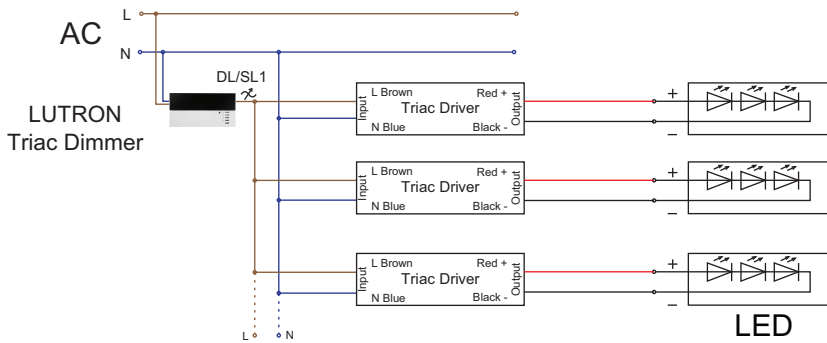
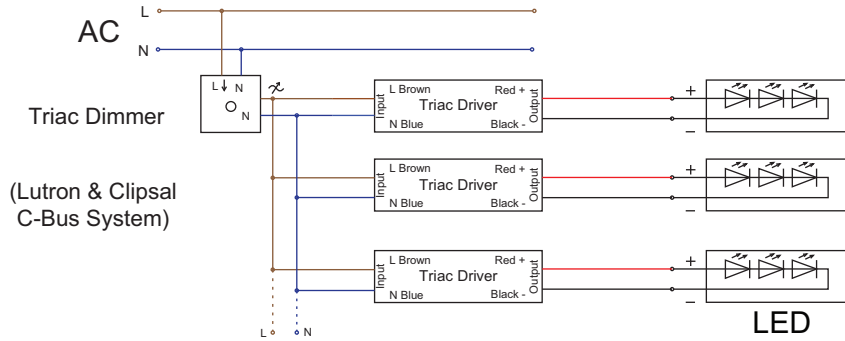
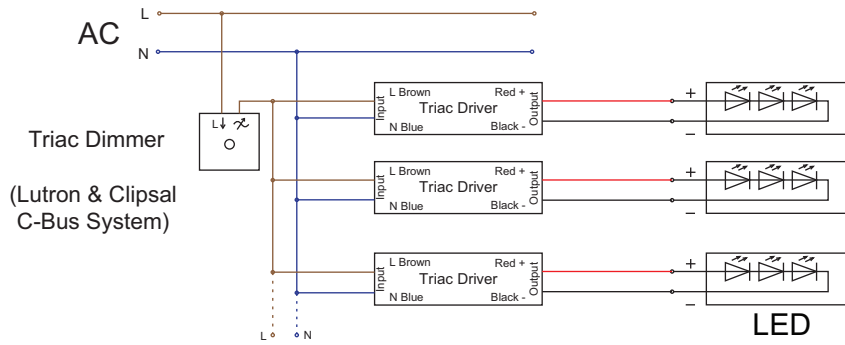

Suggested maximum distance between driver and fixtures (at maximum load)

Max. Distance (m)		
18AWG	14AWG	12AWG
10-10.5	26.5-27	42-43