

Discrete Output Module

IC670MDL331

GFK-1135E
June 1997

120 VAC Isolated, 2A Output Module

The 120 VAC Isolated Output Module (IC670MDL331) provides eight outputs arranged as four groups of 2. Each group is isolated from the others.

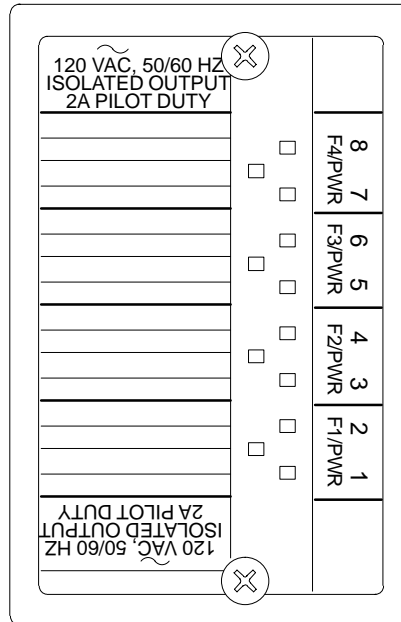

46388

Power Sources

The power that runs the module itself comes from the power supply in the Bus Interface Unit. An external source of AC power must be provided to power the loads.

LEDs

Individual LEDs (logic side), visible through the transparent portion of the module top, indicate the on/off status of each output. The abbreviations F1/PWR, F2/PWR, F3/PWR, and F4/PWR refer to the Fuse OK LED for each of the four groups.

Host Interface

Intelligent processing for this module is performed by the Bus Interface Unit or elsewhere in the system. This includes configuring features such as output default and fault reporting. The module has 8 bits (one byte) of discrete output data. A Bus Interface Unit is required to obtain this output data from the host and/or local processor.

Module Operation

After checking the Board ID and verifying that the module is receiving appropriate logic power from the Bus Interface Unit (as reflected by the state of the module's Power LED), the Bus Interface Unit then sends output data to the module in serial format. During transmission, the module automatically loops this data back to the Bus Interface Unit for verification. The module also provides the Bus Interface Unit with the diagnostic status of the fuse on each output group.

Serial to parallel converters convert this data into the parallel format needed by the module. Opto-isolators isolate the module's logic components from field outputs. Power from the external power supply is used to power the switches that drive the loads.

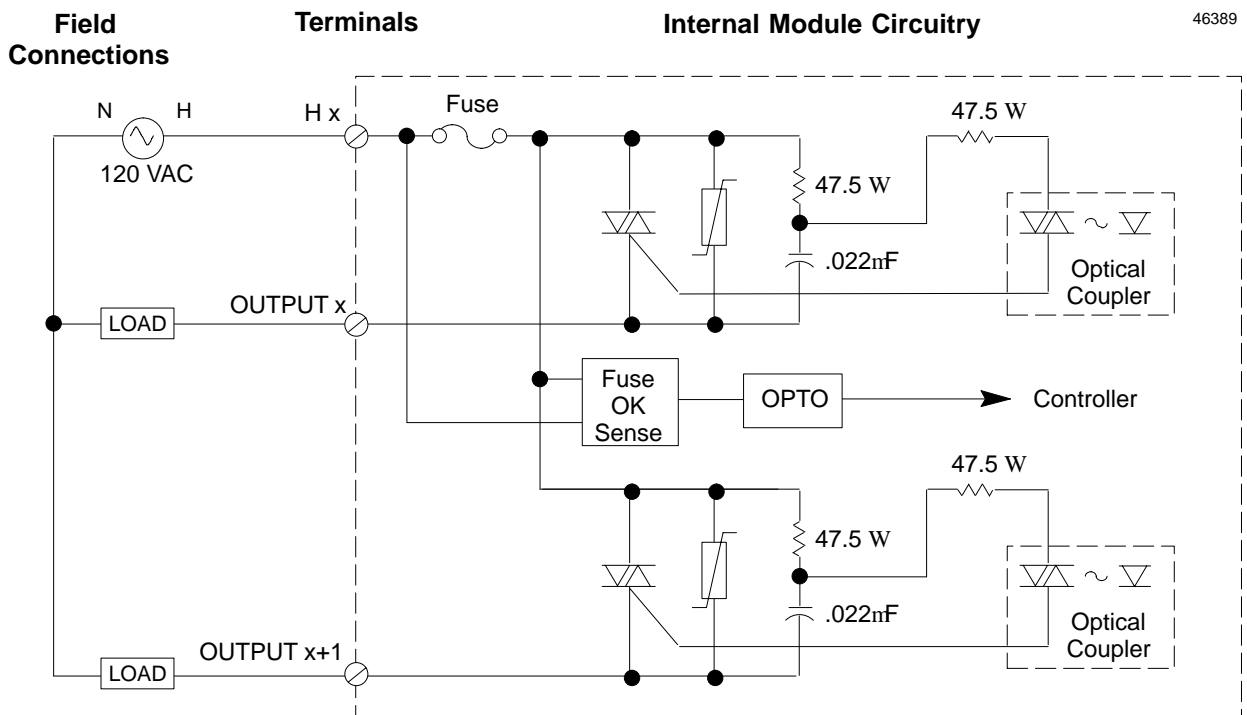

120 VAC Isolated, 2A Output ModuleGFK-1135E
June 1997**Module Specifications**

Module Characteristics	
Rated Voltage	120 VAC
Output Voltage Range	85 to 132 VAC, 47 – 63 Hz
Output Current	2 amps maximum per point (2 A max. per group) 6 to 8 amps maximum per module (see Maximum Load Rating)
Outputs per module	8 (4 groups of 2 outputs each)
Indicators	Logic side LEDs indicate on/off status of each output Fuse OK LED for each of the four groups
Isolation: User input to logic, user input to frame ground, group to group	250 VAC continuous, 1500 VAC for 1 minute. No isolation between individual points in a group.
Current Drawn from Bus Interface Unit Power Supply	154mA maximum
Output Characteristics	
Inrush Current	20A maximum for one cycle (20mS)
Maximum Load Current (resistive)	2.0 Amps from 93 VAC to 132 VAC
Minimum Load Current	10 mA per point
Output Voltage Drop	3.0 volts maximum
Output Leakage Current	2 mA at 120VAC
Response Time-On	1 ms (max)
Response Time-Off	1/2 cycle (max)
Protection (each output)	Fuse: Metric 5 x 20 mm – 3 Amp, 250 V, Slow Acting Snubber: (R=47.5 ohms, C=0.022 µfd)

Keying Locations

Optional keying locations for the 125 VAC Isolated Output Module are shown below:

Keying Locations									
A	B	C	D	E	F	G	H	J	K
	✓			✓	✓		✓		

Maximum Load Rating

The maximum rating of 2A per point applies to the longterm capacity of each point. Because of overall heat dissipation and current capacity of module pins, the maximum current capacity for each group is limited to 2 Amps. (Each group consists of two outputs).

The following illustration shows an example of the relationship between total module load current and ambient temperature.

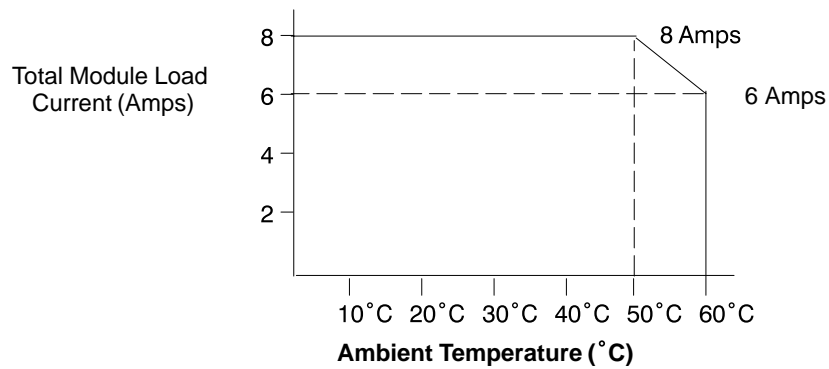

Each output on this module is capable of transiently conducting a surge current that is much greater than its long-term current rating.

The rate at which such surges can be repeated depends on the current rating of the device and the duty cycle (percent of time the device is ON). For typical incandescent devices operating at a 50% duty cycle, the following repetition rates apply:

Steady-state Current (Amps)	Repetition Rate (Hz)
0.5	5
1	1
2	0.1

120 VAC Isolated, 2A Output Module

GFK-1135E
June 1997

Field Wiring

This module has eight outputs arranged as four groups of 2. Each group is isolated from the others. Connect each pair of output devices to a pair of Output terminals (1/2, 3/4, 5/6, 7/8) on the I/O Terminal Block. Connect the other side of the output devices to the N side of the power supply. Connect the H side of the power supply to the appropriate H terminal for the two output points.

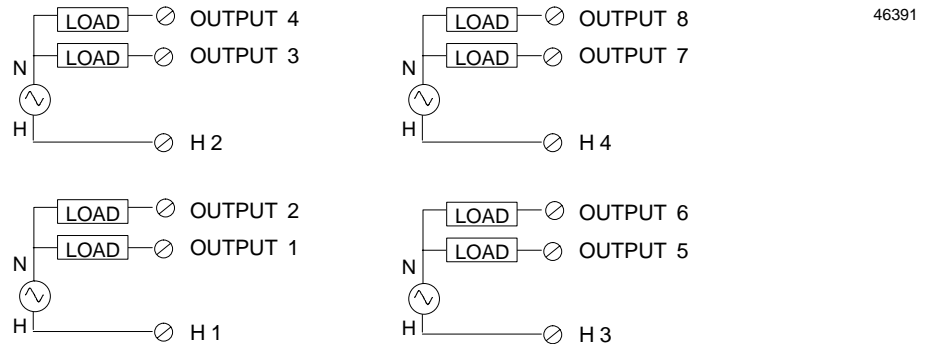

The Terminal Block with box terminals has 25 terminals for each module. Each terminal accommodates one AWG #14 (avg 2.1mm² cross section) to AWG #22 (avg 0.36mm² cross section) wire, or two wires up to AWG #18 (avg. 0.86mm² cross section). When an external jumper is used, the wire capacity is reduced from AWG #14 (2.10mm²) to AWG #16 (1.32mm²).

The I/O Terminal Block with barrier terminals has 18 terminals per module. Each terminal can accommodate one or two wires up to AWG #14 (avg 2.1mm² cross section).

The I/O Terminal Block with Connectors has one 20-pin male connector per module.

I/O Terminal Block wiring assignments for this module are shown below.

<p>I/O Terminal Block with Box Terminals (IC670CHS002 and 102) 46392</p> <table border="1" style="width: 100%; border-collapse: collapse;"> <tr><td>NC</td><td>16</td><td></td><td></td><td></td></tr> <tr><td>H4</td><td>14</td><td>15</td><td></td><td>Output 8</td></tr> <tr><td></td><td>E8</td><td>13</td><td></td><td>Output 7</td></tr> <tr><td>NC</td><td>12</td><td></td><td></td><td></td></tr> <tr><td>H3</td><td>10</td><td>11</td><td></td><td>Output 6</td></tr> <tr><td></td><td>E6</td><td>9</td><td></td><td>Output 5</td></tr> <tr><td>NC</td><td>8</td><td></td><td></td><td></td></tr> <tr><td>H2</td><td>6</td><td>7</td><td></td><td>Output 4</td></tr> <tr><td></td><td>E4</td><td>5</td><td></td><td>Output 3</td></tr> <tr><td>NC</td><td>4</td><td></td><td></td><td></td></tr> <tr><td>H1</td><td>2</td><td>3</td><td></td><td>Output 2</td></tr> <tr><td></td><td>E2</td><td>1</td><td></td><td>Output 1</td></tr> <tr><td>NC</td><td>B2</td><td>E1</td><td></td><td></td></tr> <tr><td>NC</td><td>B1</td><td>A2</td><td></td><td>NC</td></tr> <tr><td></td><td></td><td>A1</td><td></td><td>NC</td></tr> </table> <p>Terminals E1, E2, E4, E6, and E8 are electrically connected together, A1 and A2 are electrically connected together, B1 and B2 are electrically connected together.</p>	NC	16				H4	14	15		Output 8		E8	13		Output 7	NC	12				H3	10	11		Output 6		E6	9		Output 5	NC	8				H2	6	7		Output 4		E4	5		Output 3	NC	4				H1	2	3		Output 2		E2	1		Output 1	NC	B2	E1			NC	B1	A2		NC			A1		NC	<p>I/O Terminal Block with Barrier Terminals (IC670CHS001 and 101) 46393</p> <table border="1" style="width: 100%; border-collapse: collapse;"> <tr><td>NC</td><td>16</td><td>15</td><td></td><td>Output 8</td></tr> <tr><td>H4</td><td>14</td><td>13</td><td></td><td>Output 7</td></tr> <tr><td>NC</td><td>12</td><td>11</td><td></td><td>Output 6</td></tr> <tr><td>H3</td><td>10</td><td>9</td><td></td><td>Output 5</td></tr> <tr><td>NC</td><td>8</td><td>7</td><td></td><td>Output 4</td></tr> <tr><td>H2</td><td>6</td><td>5</td><td></td><td>Output 3</td></tr> <tr><td>NC</td><td>4</td><td>3</td><td></td><td>Output 2</td></tr> <tr><td>H1</td><td>2</td><td>1</td><td></td><td>Output 1</td></tr> <tr><td>NC</td><td>B</td><td>A</td><td></td><td>NC</td></tr> </table>	NC	16	15		Output 8	H4	14	13		Output 7	NC	12	11		Output 6	H3	10	9		Output 5	NC	8	7		Output 4	H2	6	5		Output 3	NC	4	3		Output 2	H1	2	1		Output 1	NC	B	A		NC	<p>I/O Terminal Block with Wire to Board Connectors (IC670CHS003 and 103) 46532</p> <table border="1" style="width: 100%; border-collapse: collapse;"> <tr><td>Output 6</td><td>11</td><td>10</td><td></td><td>H3</td></tr> <tr><td>NC</td><td>12</td><td>9</td><td></td><td>Output 5</td></tr> <tr><td>Output 7</td><td>13</td><td>8</td><td></td><td>NC</td></tr> <tr><td>H4</td><td>14</td><td>7</td><td></td><td>Output 4</td></tr> <tr><td>Output 8</td><td>15</td><td>6</td><td></td><td>H2</td></tr> <tr><td>NC</td><td>16</td><td>5</td><td></td><td>Output 3</td></tr> <tr><td>NC</td><td>A2</td><td>4</td><td></td><td>NC</td></tr> <tr><td>NC</td><td>A1</td><td>3</td><td></td><td>Output 2</td></tr> <tr><td>NC</td><td>B2</td><td>2</td><td></td><td>H1</td></tr> <tr><td>NC</td><td>B1</td><td>1</td><td></td><td>Output 1</td></tr> </table>	Output 6	11	10		H3	NC	12	9		Output 5	Output 7	13	8		NC	H4	14	7		Output 4	Output 8	15	6		H2	NC	16	5		Output 3	NC	A2	4		NC	NC	A1	3		Output 2	NC	B2	2		H1	NC	B1	1		Output 1
NC	16																																																																																																																																																																											
H4	14	15		Output 8																																																																																																																																																																								
	E8	13		Output 7																																																																																																																																																																								
NC	12																																																																																																																																																																											
H3	10	11		Output 6																																																																																																																																																																								
	E6	9		Output 5																																																																																																																																																																								
NC	8																																																																																																																																																																											
H2	6	7		Output 4																																																																																																																																																																								
	E4	5		Output 3																																																																																																																																																																								
NC	4																																																																																																																																																																											
H1	2	3		Output 2																																																																																																																																																																								
	E2	1		Output 1																																																																																																																																																																								
NC	B2	E1																																																																																																																																																																										
NC	B1	A2		NC																																																																																																																																																																								
		A1		NC																																																																																																																																																																								
NC	16	15		Output 8																																																																																																																																																																								
H4	14	13		Output 7																																																																																																																																																																								
NC	12	11		Output 6																																																																																																																																																																								
H3	10	9		Output 5																																																																																																																																																																								
NC	8	7		Output 4																																																																																																																																																																								
H2	6	5		Output 3																																																																																																																																																																								
NC	4	3		Output 2																																																																																																																																																																								
H1	2	1		Output 1																																																																																																																																																																								
NC	B	A		NC																																																																																																																																																																								
Output 6	11	10		H3																																																																																																																																																																								
NC	12	9		Output 5																																																																																																																																																																								
Output 7	13	8		NC																																																																																																																																																																								
H4	14	7		Output 4																																																																																																																																																																								
Output 8	15	6		H2																																																																																																																																																																								
NC	16	5		Output 3																																																																																																																																																																								
NC	A2	4		NC																																																																																																																																																																								
NC	A1	3		Output 2																																																																																																																																																																								
NC	B2	2		H1																																																																																																																																																																								
NC	B1	1		Output 1																																																																																																																																																																								

Fusing

Each group of two outputs is fused with a 3 Amp fuse. Replacement fuses must be:

Metric 5 x 20 mm – 3 Amp, 250 V, Slow Acting

If a fuse blows, its corresponding LED goes off. In addition, the module provides a Blown Fuse diagnostic message to the BIU.

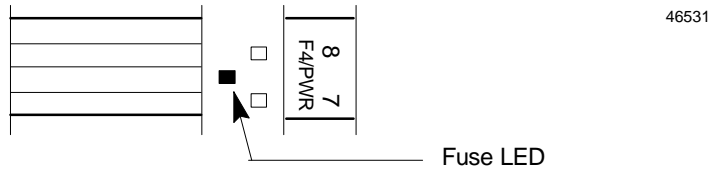

If a fuse blows, disconnect power, remove the module and replace the fuse. *CAUTION: Electrostatic discharge can damage the module when it is not installed on an I/O Terminal Block. Always observe normal ESD protection practices when handling an un-installed module.*

Fuse locations correspond to the LED positions (F1/PWR through F4/PWR) in the front of the module. See below for fuse locations.

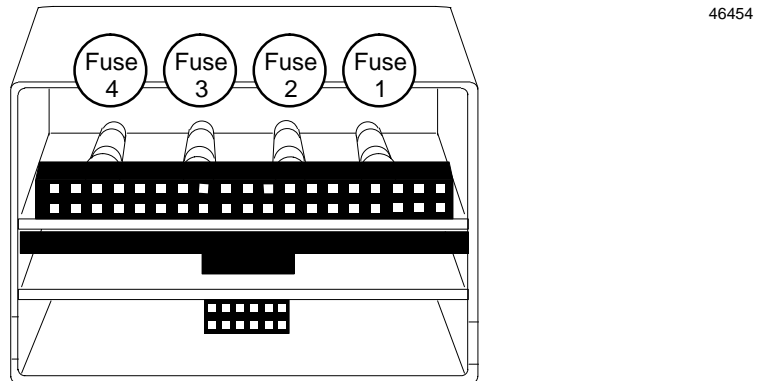

Carefully pry the fuse upward to remove it, taking care not to damage any components in the module. Place the new fuse in position and press it into the holder.

Spare fuses can be stored in the fuse holder compartment of the I/O Terminal Block (under the I/O module).