

# Discrete Output Module

IC670MDL330

GFK-1355B  
June 1997

## 12-120 VAC 1.0A Output Module

The 12-120 VAC 1.0 Amp Output Module (IC670MDL330) provides a single group of 16 discrete outputs.

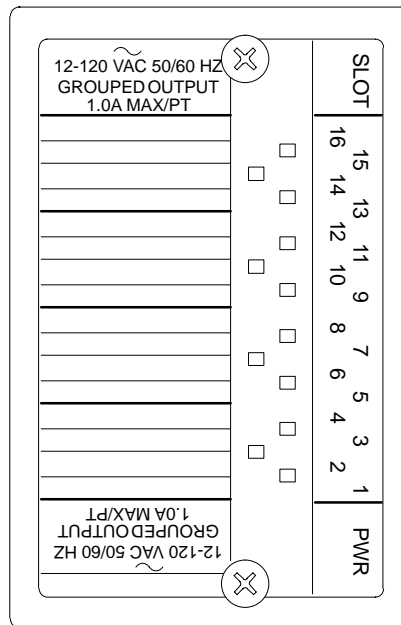

46750

### Power Sources

The power that runs the module itself comes from the power supply in the Bus Interface Unit. An external source of AC power must be provided to power the loads.

### LEDs

Individual LEDs (logic side), visible through the transparent portion of the module top, indicate the on/off status of each output.

### Host Interface

Intelligent processing for this module is performed by the Bus Interface Unit or elsewhere in the system. This includes configuring features such as output default and fault reporting. The module has 16 bits (two bytes) of discrete output data. A Bus Interface Unit is required to obtain this output data from the host and/or local processor.

## Module Operation

After checking the Board ID and verifying that the module is receiving appropriate logic power from the Bus Interface Unit (as reflected by the state of the module's Power LED), the Bus Interface Unit then sends output data to the module in serial format. During transmission, the module automatically loops this data back to the Bus Interface Unit for verification. The module also provides the Bus Interface Unit with the diagnostic status of the fuse on the output group.

Serial to parallel converters convert this data into the parallel format needed by the module. Opto-isolators isolate the module's logic components from field outputs. Power from the external power supply is used to power the switches that drive the loads.

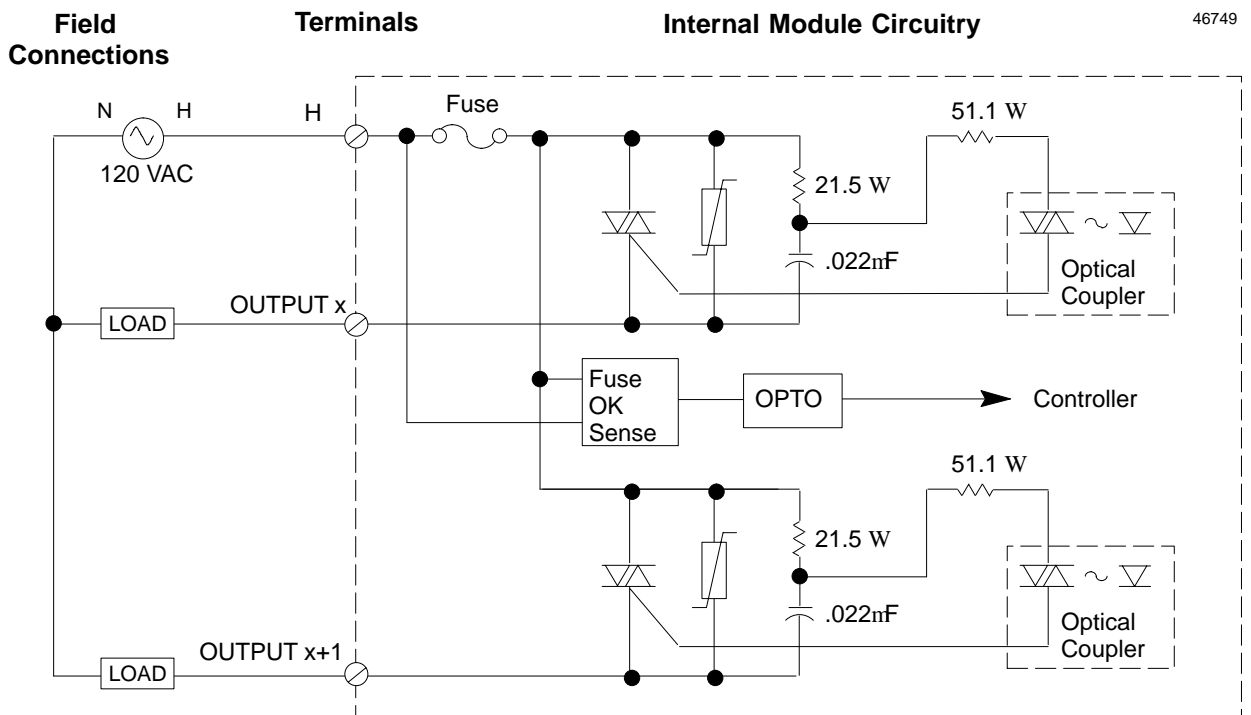

**12-120 VAC 1.0A Output Module**

GFK-1355B

June 1997

**Module Specifications**

<b>Module Characteristics</b>	
Rated Voltage	12 to 120 VAC
Output Voltage Range	10 to 132 VAC, 47 – 63 Hz
Output Current	1 amp maximum per point 4 amps maximum per module (see Maximum Load Rating)
Outputs per module	1 group of 16
Indicators	Logic side LEDs indicate on/off status of each output Fuse OK LED for all 16 groups
Isolation:	
User input to logic, user input to frame ground	250 VAC continuous, 1500 VAC for 1 minute
Point to point	No isolation between individual points in a group.
Current Drawn from Bus Interface Unit Power Supply	275 mA with all points on. See the BIU power requirements chart on the next page.
<b>Output Characteristics</b>	
Inrush Current	10A maximum for one cycle (20mS)
Maximum Load Current (resistive)	1.0 A from 10 VAC to 132 VAC
Minimum Load Current	10 mA per point from 10 VAC to 132 VAC
Output Voltage Drop	2.0 volts maximum
Output Leakage Current	less than 2 mA maximum at 120 VAC
Response Time-On	less than 1/2 cycle
Response Time-Off	less than 1/2 cycle
Protection (each output)	Snubber: (R=21.5 ohms, C=0.022 µfd)

**Keying Locations**

Optional keying locations for the 120 VAC 16 Point Output Module are shown below:

<b>Keying Locations</b>									
A	B	C	D	E	F	G	H	J	K
	✓			✓	✓		✓		

### Maximum Load Rating

The maximum rating of 1 Amp per point applies to the longterm capacity of each point. Because of overall heat dissipation and current capacity of module pins, the maximum current capacity for each module is limited to 4 Amps with proper derating.

The following illustration shows an example of the relationship between total module load current and ambient temperature.

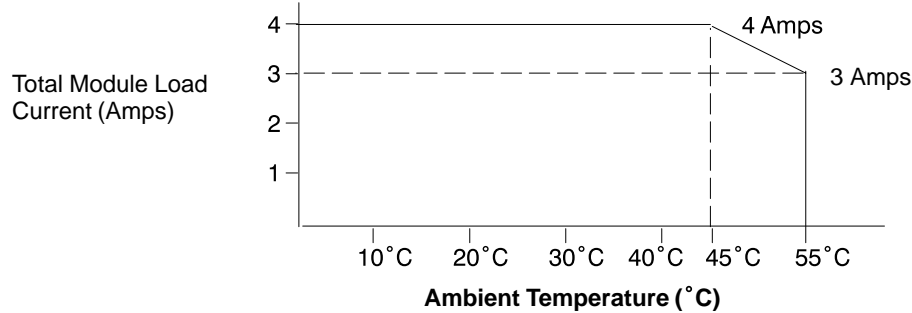

46748

Each output on this module is capable of transiently conducting a surge current that is much greater than its long-term current rating.

The rate at which such surges can be repeated depends on the current rating of the device and the duty cycle (percent of time the device is ON). For typical incandescent devices operating at a 50% duty cycle, the following repetition rates apply:

Steady-state Current (Amps)	Repetition Rate (Hz)
0.5	5
1	1

### BIU Power Required, per Point

The module's BIU power requirement increases as the number of points that are simultaneously on increases. The chart below shows the relationship between the power required and the number of points that are on.

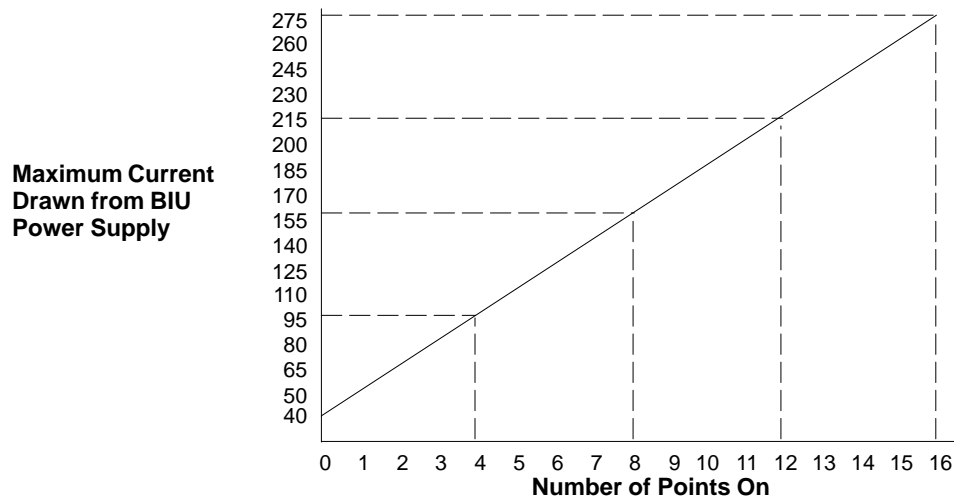

46751

**12–120 VAC 1.0A Output Module**

GFK-1355B

June 1997

## Fusing

The module's 5 Amp fuse protects the entire module from exceeding the maximum current rating. The fuse does not protect output points from exceeding the maximum per-point current rating.

If the fuse blows, the module's PWR LED goes off and a Blown Fuse diagnostic is sent to the BIU.

Replacement fuses must be:

**5A, 5 x 20mm slow-blow type**

If the fuse blows, disconnect power, remove the module and replace the fuse. *CAUTION: Electrostatic discharge can damage the module when it is not installed on an I/O Terminal Block. Always observe normal ESD protection practices when handling an un-installed module.*

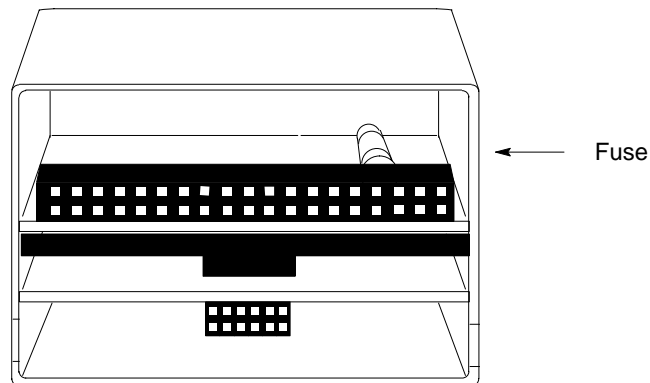

Carefully pry the fuse upward to remove it, taking care not to damage any components in the module. Place the new fuse in position and press it into the holder.

Spare fuses can be stored in the fuse holder compartment of the I/O Terminal Block (under the I/O module).

## Field Wiring

The Terminal Block with box terminals has 25 terminals for each module. Each terminal accommodates one AWG #14 (avg 2.1mm<sup>2</sup> cross section) to AWG #22 (avg 0.36mm<sup>2</sup> cross section) wire, or two wires up to AWG #18 (avg. 0.86mm<sup>2</sup> cross section). When an external jumper is used, the wire capacity is reduced from AWG #14 (2.10mm<sup>2</sup>) to AWG #16 (1.32mm<sup>2</sup>).

The I/O Terminal Block with barrier terminals has 18 terminals per module. Each terminal can accommodate one or two wires up to AWG #14 (avg 2.1mm<sup>2</sup> cross section).

The I/O Terminal Block with Connectors has one 20-pin male connector per module.

I/O Terminal Block wiring assignments for this module are shown below.

