



POWER SUPPLY

- AC 100-120V / 200-240V Auto-Select Input
- Cost Optimized without Compromising Quality or Reliability.
- Width only 39mm
- Efficiency up to 92.3%
- Full Power Between -10°C and +55°C
- DC-OK Relay Contact Included
- 3 Year Warranty

GENERAL DESCRIPTION

These PIANO series units are extraordinarily compact, industrial grade power supplies that focus on the essential features needed in today's industrial applications. The excellent cost/performance ratio presents many new and exciting opportunities without compromising quality or reliability.

The mechanically robust housing is made of a high-grade, reinforced molded material, which permits the units to be used in surrounding temperatures up to 70°C.

The unit is equipped with a auto-select input voltage stage, which makes the unit suitable for global use.

The addition of a DC-OK signal makes the unit suitable for many industry applications such as: process, automation and many other critical applications where preventive function monitoring can help to avoid long downtimes.

SHORT-FORM DATA

Output voltage	DC 24V	
	24 - 28Vdc	Adjustment range
Output	for AC 110-120 / 220-240V mains:	
	5.0 - 4.3A	at 24-28V, <55°C
	3.1 - 2.7A	at 24-28V, <70°C
	for AC 100 / 200V mains:	
	5.0 - 4.3A	at 24-28V, <50°C
	2.5 - 2.1A	at 24-28V, <70°C
Output ripple	< 100mVpp	20Hz to 20MHz
AC Input voltage	AC 100-120V / 200-240V	±10% Auto-Select
Mains frequency	50-60Hz	±6%
AC Input current	1.72A / 1.05A	at 120/ 230Vac
Power factor	0.64 / 0.54	at 120/ 230Vac
AC Inrush current	22A / 33A peak	at 120/ 230Vac, 40°C
Efficiency	91.2% / 92.3%	at 120/ 230Vac
Losses	11.6W / 10.0W	at 120/ 230Vac
Temp. range	-10°C to +70°C	operational
Derating	3W/°C	+55 to +70°C*)
Hold-up time	51ms / 50ms	at 120/ 230Vac
Dimensions	39x124x124mm	WxHxD
Weight	370g / 0.81lb	

*) +50 to +70°C for AC 100V / 200V mains

ORDER NUMBERS

Power Supply	PIC120.241D	24-28V Unit
Accessory	YR2.DIODE UF20.241	Redundancy module Buffer Module

MARKINGS





INDEX

	Page		Page
1. Intended Use	3	19. Approvals	16
2. Installation Requirements.....	3	20. RoHS, REACH and Other Fulfilled Standards ..	16
3. AC-Input.....	4	21. Physical Dimensions and Weight	17
4. DC-Input.....	5	22. Accessory.....	18
5. Input Inrush Current	5	22.1. UF20.241 Buffer module	18
6. Output	6	22.2. YR2.DIODE Redundancy Module.....	18
7. Hold-up Time.....	7	23. Application Notes.....	19
8. DC-OK Relay Contact	7	23.1. Peak Current Capability	19
9. Efficiency and Power Losses.....	8	23.2. Back-feeding Loads	19
10. Lifetime Expectancy and MTBF.....	9	23.3. External Input Protection.....	20
11. Functional Diagram.....	9	23.4. Parallel Use to Increase Output Power....	20
12. Terminals and Wiring.....	10	23.5. Parallel Use for Redundancy	20
13. Front Side and User Elements.....	11	23.6. Series Operation	21
14. EMC.....	12	23.7. Inductive and Capacitive Loads.....	21
15. Environment	13	23.8. Charging of Batteries	21
16. Protection Features	14	23.9. Operation on Two Phases	22
17. Safety Features	14	23.10. Use in a Tightly Sealed Enclosure	22
18. Dielectric Strength	15		

The information presented in this document is believed to be accurate and reliable and may change without notice. No part of this document may be reproduced or utilized in any form without permission in writing from the publisher.

TERMINOLOGY AND ABBREVIATIONS

PE and  symbol	PE is the abbreviation for Protective Earth and has the same meaning as the symbol  .
Earth, Ground	This document uses the term "earth" which is the same as the U.S. term "ground".
T.b.d.	To be defined, value or description will follow later.
AC 230V	A figure displayed with the AC or DC before the value represents a nominal voltage with standard tolerances included. E.g.: DC 12V describes a 12V battery disregarding whether it is full (13.7V) or flat (10V)
230Vac	A figure with the unit (Vac) at the end is a momentary figure without any additional tolerances included.
50Hz vs. 60Hz	As long as not otherwise stated, AC 100V and AC 230V parameters are valid at 50Hz mains frequency. AC 120V parameters are valid for 60Hz mains frequency.
may	A key word indicating flexibility of choice with no implied preference.
shall	A key word indicating a mandatory requirement.
should	A key word indicating flexibility of choice with a strongly preferred implementation.

1. INTENDED USE

This device is designed for installation in an enclosure and is intended for the general professional use such as in industrial control, office, communication, and instrumentation equipment.

Do not use this power supply in equipment, where malfunction may cause severe personal injury or threaten human life.

2. INSTALLATION REQUIREMENTS

This device may only be installed and put into operation by qualified personnel.

This device does not contain serviceable parts. The tripping of an internal fuse is caused by an internal defect.

If damage or malfunction should occur during installation or operation, immediately turn power off and send unit to the factory for inspection.

Mount the unit on a DIN-rail so that the input terminals are located on the bottom of the unit.

This device is designed for convection cooling and does not require an external fan. Do not obstruct airflow and do not cover ventilation grid (e.g. cable conduits) by more than 15%!

Keep the following installation clearances: 40mm on top, 20mm on the bottom, 5mm on the left and right sides are recommended when the device is loaded permanently with more than 50% of the rated power. Increase this clearance to 15mm in case the adjacent device is a heat source (e.g. another power supply).

A disconnecting means shall be provided for the output of the power supplies when used in applications according to CSA C22.2 No 107.1-01.

⚠ WARNING Risk of electrical shock, fire, personal injury or death.

- Do not use the power supply without proper grounding (Protective Earth). Use the terminal on the input block for earth connection.
- Turn power off before working on the device. Protect against inadvertent re-powering.
- Make sure that the wiring is correct by following all local and national codes.
- Do not modify or repair the unit.
- Do not open the unit as high voltages are present inside.
- Use caution to prevent any foreign objects from entering the housing.
- Do not use in wet locations or in areas where moisture or condensation can be expected.
- Do not touch during power-on, and immediately after power-off. Hot surfaces may cause burns.

3. AC-INPUT

AC input	nom.	AC 100-120V / 200-240V	Auto-select, suitable for TN-, TT- and IT mains networks
AC input range	min.	90-132Vac / 180- 264Vac	continuous operation
	min.	264-300Vac	< 500ms
Allowed voltage L or N to earth	max.	300Vac	continuous, IEC 62103
Input frequency	nom.	50–60Hz	±6%
External input protection	See recommendations in chapter 23.3.		

		AC 100V	AC 120V	AC 230V	
Input current	typ.	2.0A	1.72A	1.05A	at 24V, 5A, see Fig. 3-3
Power factor ^{*)}	typ.	0.66	0.64	0.54	at 24V, 5A, see Fig. 3-4
Crest factor ^{**)}	typ.	2.7	2.8	3.4	at 24V, 5A
Turn-on voltage	typ.	78Vac	78Vac	157Vac	at 24V 0A, steady-state value, see Fig. 3-1
Shut-down voltage	typ.	68Vac	68Vac	68Vac	at 24V 5A, steady-state value, see Fig. 3-1
Start-up delay	typ.	400ms	400ms	100ms	see Fig. 3-2
Rise time	typ.	30ms	30ms	30ms	at 24V, 5A const. current load, 0mF load capacitance, see Fig. 3-2
	typ.	90ms	90ms	90ms	at 24V, 5A const. current load, 5mF load capacitance,, see Fig. 3-2
Turn-on overshoot	max.	200mV	200mV	200mV	see Fig. 3-2

*) The power factor is the ratio of the true (or real) power to the apparent power in an AC circuit.

***) The crest factor is the mathematical ratio of the peak value to RMS value of the input current waveform.

Fig. 3-1 Input voltage range, typ.

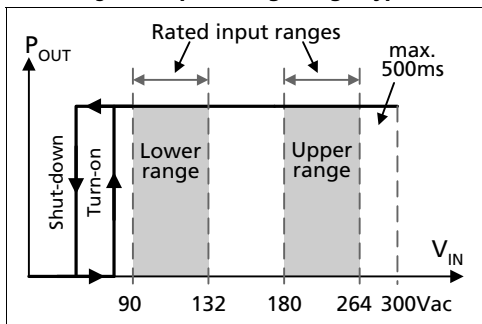

Fig. 3-3 Input current vs. output load at 24V

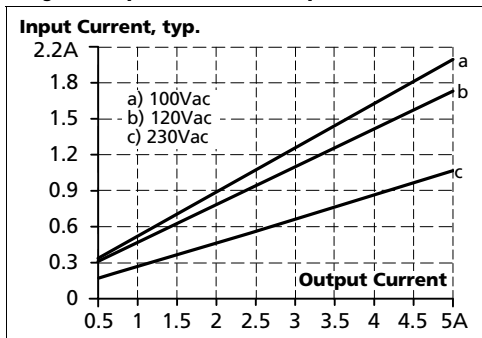

Fig. 3-2 Turn-on behavior, definitions

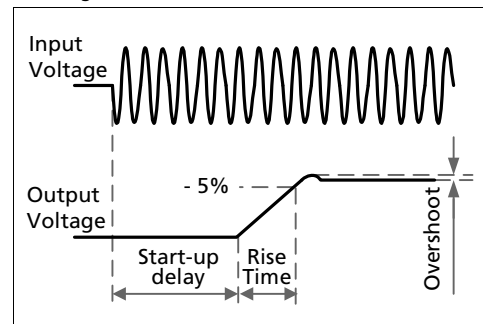
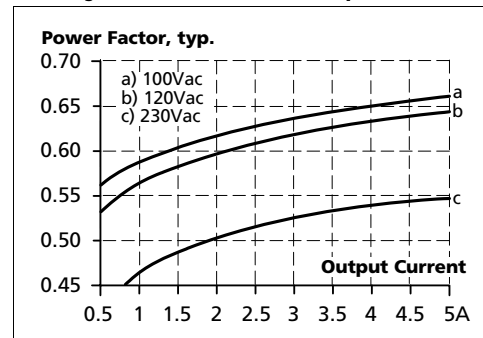

Fig. 3-4 Power factor vs. output load



4. DC-INPUT

Do not operate this power supply with DC-input voltage.

5. INPUT INRUSH CURRENT

A NTC inrush limiter limits the input inrush current after turn-on of the input voltage.

		AC 100V	AC 120V	AC 230V	
Inrush current ^{*)}	max.	23A _{peak}	27A _{peak}	40A _{peak}	40°C ambient, cold start
	typ.	18A _{peak}	22A _{peak}	33A _{peak}	40°C ambient, cold start
	typ.	13A _{peak}	16A _{peak}	30A _{peak}	25°C ambient, cold start
Inrush energy ^{*)}	max.	0.4A ² s	0.5A ² s	1.5A ² s	40°C ambient, cold start

^{*)} The charging current into EMI suppression capacitors is disregarded in the first microseconds after switch-on.

Fig. 5-1 Input inrush current, typical behavior
230Vac input, 24V 5A output, 40°C ambient

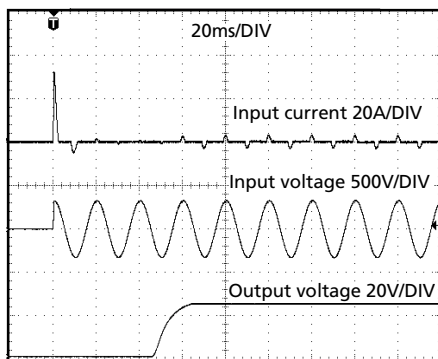
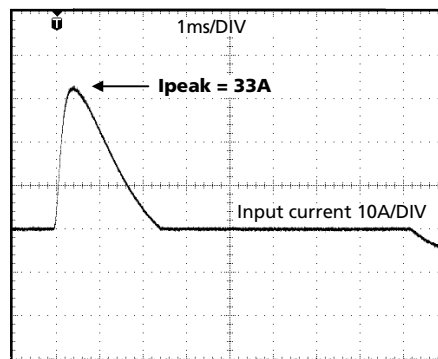

Fig. 5-2 Input inrush current, zoom into first peak
230Vac input, 24V 5A output, 40°C ambient



6. OUTPUT

Output voltage	nom.	DC 24V	
Adjustment range	min.	24-28V	guaranteed
	max.	30V ^{**)}	at clockwise end position of potentiometer
Factory settings	typ.	24.1V	±0.2%, at full load, cold unit
Line regulation	max.	10mV	90-132 / 180-264Vac
Load regulation	max.	150mV	static value, 0A → 5A → 0A
Ripple and noise voltage	max.	100mVpp	20Hz to 20MHz, 50Ohm
Output current	for AC 110-120 / 220-240V mains voltages (includes AC 208V mains):		
	nom.	5A	at 24V, below +55°C ambient temperature
	nom.	4.3A	at 28V, below +55°C ambient temperature
	nom.	3.1A	at 24V, at +70°C ambient temperature
	nom.	2.7A	at 28V, at +70°C ambient temperature
	Derate linearly between +55°C and +70°C		
	for AC 100 / 200V mains voltages:		
	nom.	5A	at 24V, below +50°C ambient temperature
	nom.	4.3A	at 28V, below +50°C ambient temperature
	nom.	2.5A	at 24V, at +70°C ambient temperature
nom.	2.1A	at 28V, at +70°C ambient temperature	
Derate linearly between +50°C and +70°C			
Overload behaviour	continuous current	output voltage > 10Vdc, see Fig. 6-1	
	Intermittent	output voltage < 10Vdc, see Fig. 6-1	
Short-circuit current	typ.	3.5A ^{*)}	average (R.M.S.) current, load impedance 50mOhm
Output capacitance	typ.	2 050µF	included inside the power supply

*) Discharge current of output capacitors is not included.

***) This is the maximum output voltage which can occur at the clockwise end position of the potentiometer due to tolerances. It is not guaranteed value which can be achieved. The typical value is about 28.5V.

Fig. 6-1 Output voltage vs. output current, RMS current, typ.

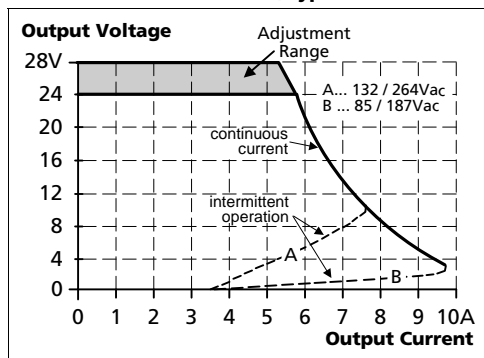
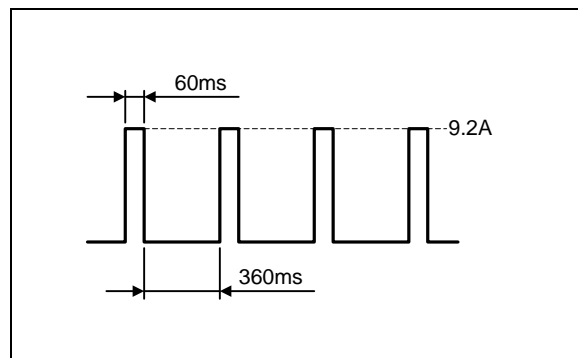

Fig. 6-2 Intermittent operation at shorted output, typ.



7. HOLD-UP TIME

		AC 100V	AC 120V	AC 230V	
Hold-up Time	typ.	64ms	108ms	105ms	at 24V, 2.5A, see Fig. 7-1
	min.	54ms	91ms	88ms	at 24V, 2.5A, see Fig. 7-1
	typ.	26ms	51ms	50ms	at 24V, 5A, see Fig. 7-1
	min.	22ms	43ms	42ms	at 24V, 5A, see Fig. 7-1

Fig. 7-1 Hold-up time vs. input voltage

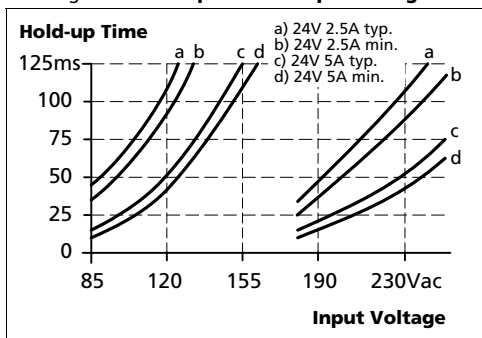
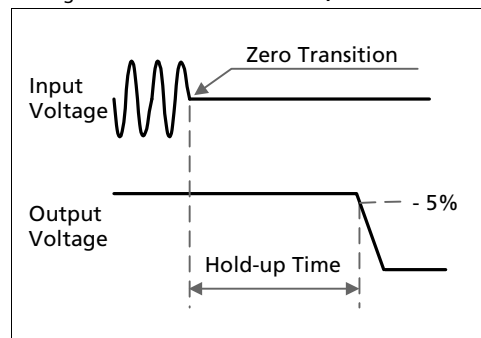

Fig. 7-2 Shut-down behavior, definitions



8. DC-OK RELAY CONTACT

This feature monitors the output voltage, which is produced by the power supply itself. It is independent of a back-fed voltage from a unit connected in parallel to the power supply output (e.g. redundant application).

Contact closes	As soon as the output voltage reaches 21.4V.		
Contact opens	As soon as the output voltage dips below 21.4V.		
Contact ratings	max.	60Vdc 0.3A, 30Vdc 1A, 30Vac 0.5A	resistive load
	min.	1mA at 5Vdc	minimum required load
Isolation voltage	See dielectric strength table in section 18.		

Fig. 8-1 DC-ok relay contact behavior

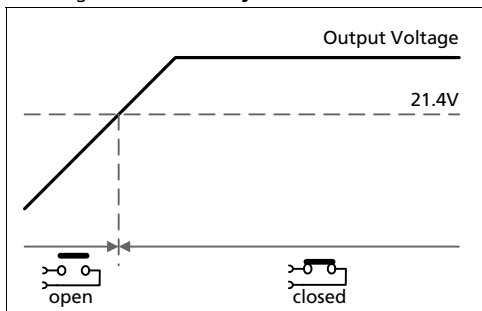

9. EFFICIENCY AND POWER LOSSES

		AC 100V	AC 120V	AC 230V	
Efficiency	typ.	90.7%	91.2%	92.3%	at 24V, 5A
Average efficiency*)	typ.	89.2%	89.4%	90.6%	25% at 1.25A, 25% at 2.5A, 25% at 3.75A, 25% at 5A
Power losses	typ.	1.4W	1.5W	0.7W	at 24V, 0A
	typ.	7.0W	7.4W	6.0W	at 24V, 2.5A
	typ.	12.3W	11.6W	10.0W	at 24V, 5A

*) The average efficiency is an assumption for a typical application where the power supply is loaded with 25% of the nominal load for 25% of the time, 50% of the nominal load for another 25% of the time, 75% of the nominal load for another 25% of the time and with 100% of the nominal load for the rest of the time.

Fig. 9-1 Efficiency vs. output current at 24V, typ.

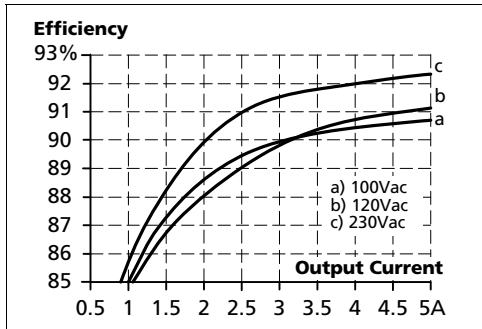

Fig. 9-2 Losses vs. output current at 24V, typ.

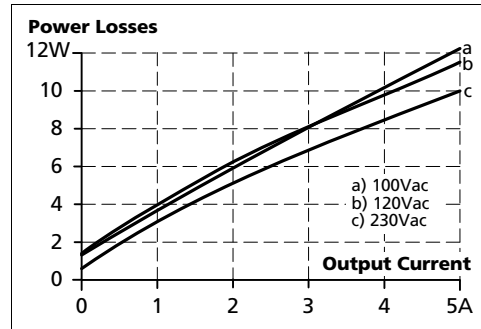

Fig. 9-3 Efficiency vs. input voltage at 24V, 5A, typ.

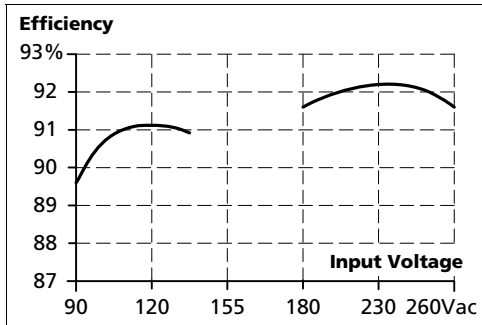
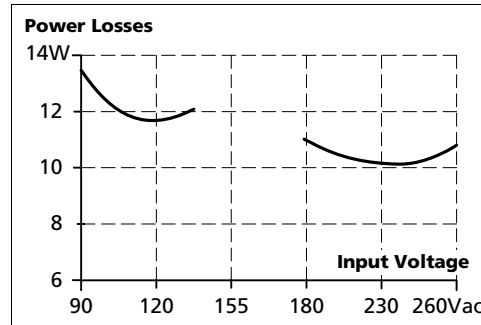

Fig. 9-4 Losses vs. input voltage at 24V, 5A, typ.



10. LIFETIME EXPECTANCY AND MTBF

	AC 100V	AC 120V	AC 230V	
Lifetime expectancy ^{*)}	181 000h ^{*)}	194 000h ^{*)}	219 000h ^{*)}	at 24V, 2.5A and 40°C
	511 000h ^{*)}	548 000h ^{*)}	621 000h ^{*)}	at 24V, 2.5A and 25°C
	66 000h	68 000h	83 000h	at 24V, 5A and 40°C
	188 000h ^{*)}	193 000h ^{*)}	234 000h ^{*)}	at 24V, 5A and 25°C
MTBF ^{**) SN 29500, IEC 61709}	1 065 000h	1 147 000h	1 379 000h	at 24V, 5A and 40°C
	2 038 000h	2 166 000h	2 519 000h	at 24V, 5A and 25°C
MTBF ^{**) MIL HDBK 217F}	681 000h	651 000h	645 000h	at 24V, 5A and 40°C; Ground Benign GB40
	872 000h	842 000h	839 000h	at 24V, 5A and 25°C; Ground Benign GB25
	165 000h	164 000h	168 000h	at 24V, 5A and 40°C; Ground Fixed GF40
	206 000h	205 000h	211 000h	at 24V, 5A and 25°C; Ground Fixed GF25

- *) The **Lifetime expectancy** shown in the table indicates the minimum operating hours (service life) and is determined by the lifetime expectancy of the built-in electrolytic capacitors. Lifetime expectancy is specified in operational hours and is calculated according to the capacitor's manufacturer specification. The manufacturer of the electrolytic capacitors only guarantees a maximum life of up to 15 years (131 400h). Any number exceeding this value is a calculated theoretical lifetime which can be used to compare devices.
- **) **MTBF** stands for **Mean Time Between Failure**, which is calculated according to statistical device failures, and indicates reliability of a device. It is the statistical representation of the likelihood of a unit to fail and does not necessarily represent the life of a product. The MTBF figure is a statistical representation of the likelihood of a device to fail. A MTBF figure of e.g. 1 000 000h means that statistically one unit will fail every 100 000 units are installed in the field. However, it can not be determined if the failed unit has been running for 50 000h or only for 100h.

11. FUNCTIONAL DIAGRAM

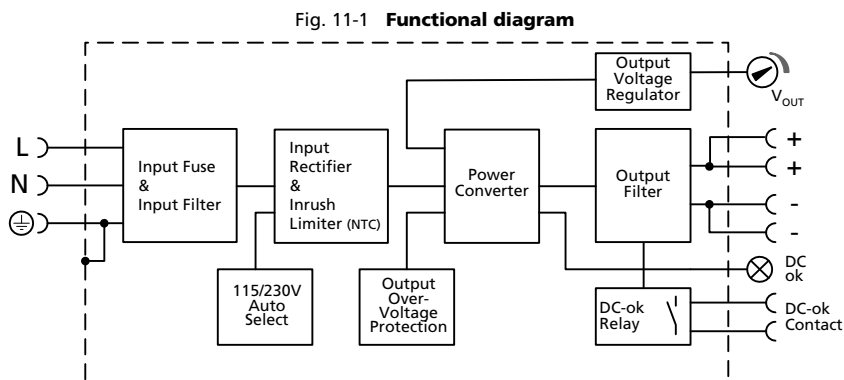

12. TERMINALS AND WIRING

The terminals are IP20 finger safe constructed and suitable for field- and factory wiring.

	Input and output	DC-OK-Signal
Type	screw terminals	push-in terminals
Solid wire	max. 6mm ²	max. 1.5mm ²
Stranded wire	max. 4mm ²	max. 1.5mm ²
American Wire Gauge	AWG20-10	AWG28-16
Max. wire diameter	2.8mm (including ferrules)	1.6mm (including ferrules)
Wire stripping length	7mm / 0.28inch	7mm / 0.28inch
Screwdriver	3.5mm slotted or cross-head No 2	not required
Recommended tightening torque	1Nm, 9lb.in	not applicable

Instructions:

- a) Use appropriate copper cables that are designed for minimum operating temperatures of: 75°C for ambient up to 55°C minimum and 90°C for ambient up to 70°C minimum.
- b) Follow national installation codes and installation regulations!
- c) Ensure that all strands of a stranded wire enter the terminal connection!
- d) Do not use the unit without PE connection.
- e) Unused terminal compartments should be securely tightened.
- f) Ferrules are allowed.