

### Junction Box: Back Panels

BP1414CSW | 077867

Back Panels of the appropriate size are available to fit the Scepter JBox in the 6 x 6 size and larger. IPEX back panels are made of 14 gauge carbon steel and have a white epoxy powder coat finish. Panels have pre-drilled holes that correspond to the mounting posts in the Scepter JBox to be easily attached using Pan Head #10 X 1/2" thread forming screws.

#### APPLICATION / USE

JBX junction boxes can be used to enclose electrical equipment in non-hazardous locations. Back panels provide a means for mounting devices and equipment in an enclosure without compromising the NEMA rating of the enclosure.

#### MATERIAL

#14 gauge carbon steel,  
white epoxy powder coat

#### FASTENER

Pan Head #10 X 1/2"  
thread-forming screw

#### PACKAGING

Carton Quantity: 8  
Carton Weight: 29.7 lbs / 13.5 kg

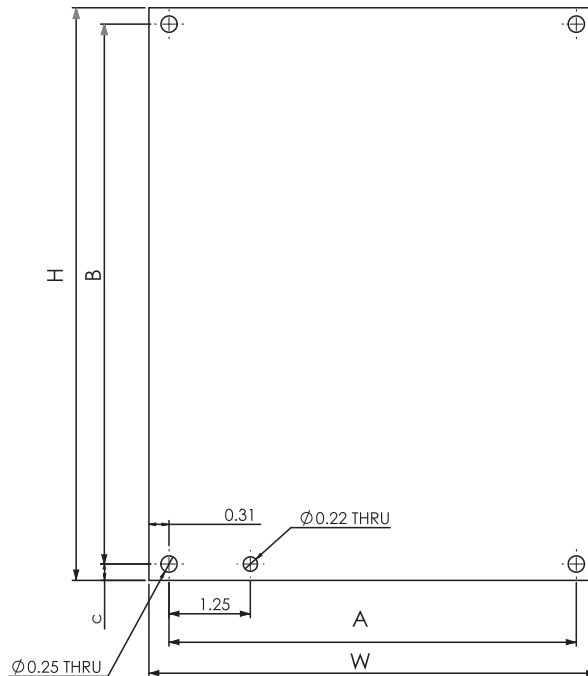

Trade Size	Part No.	Product Code	Dimensions (inches)				
			W	H	A	B	C
14 x 14	BP1414CSW	077867	10.88	12.75	10.26	12.25	0.25

### Junction Box: Back Panels

BP1616CSW | 077868

Back Panels of the appropriate size are available to fit the Scepter JBox in the 6 x 6 size and larger. IPEX back panels are made of 14 gauge carbon steel and have a white epoxy powder coat finish. Panels have pre-drilled holes that correspond to the mounting posts in the Scepter JBox to be easily attached using Pan Head #10 X 1/2" thread forming screws.

#### APPLICATION / USE

JBX junction boxes can be used to enclose electrical equipment in non-hazardous locations. Back panels provide a means for mounting devices and equipment in an enclosure without compromising the NEMA rating of the enclosure.

#### MATERIAL

#14 gauge carbon steel,  
white epoxy powder coat

#### FASTENER

Pan Head #10 X 1/2"  
thread-forming screw

#### PACKAGING

Carton Quantity: 8  
Carton Weight: 39.2 lbs / 17.8 kg

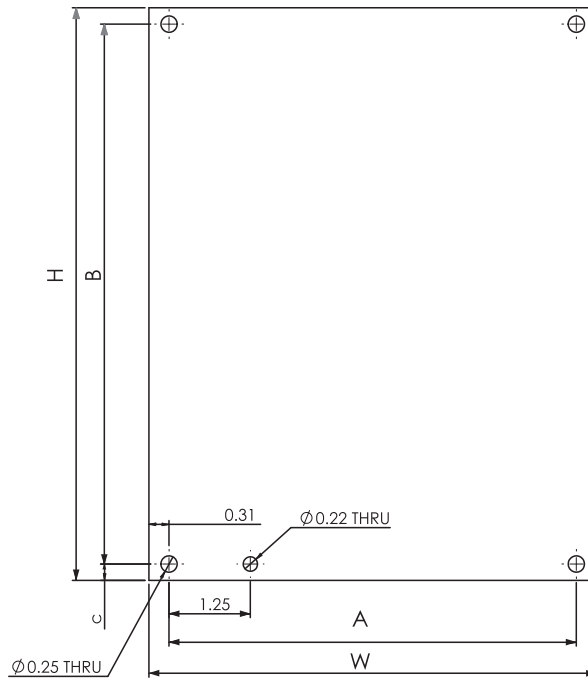

Trade Size	Part No.	Product Code	Dimensions (inches)				
			W	H	A	B	C
16 x 16	BP1616CSW	077868	12.88	14.75	12.26	14.25	0.25