

# Feed-through blocks with screw connection

UL wire connection versions

<sup>4)</sup> or 2x no. 14 sol/str AWG  
or 2x no. 16 sol/str AWG  
or 2x no. 18 sol/str AWG  
or 3x no. 20 sol/str AWG or 3x no. 22 sol/str AWG

<sup>5)</sup> or 2x no. 12 sol/str AWG  
or 2x no. 16 sol/str AWG  
or 3x no. 18 sol/str AWG or 3x no. 22 sol/str AWG

<sup>6)</sup> or 2x no. 12 sol/str AWG  
or 2x no. 14 sol/str AWG  
or 3x no. 16 sol/str AWG

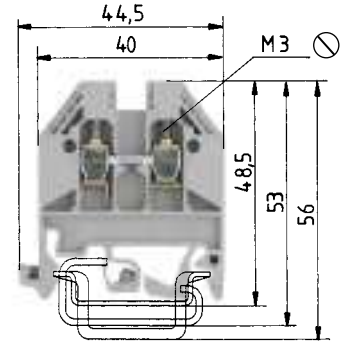
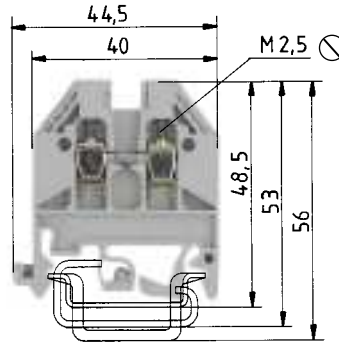

0344 II 2GD IM2  
Ex e I/II  
EN 60947-7-1  
UL ratings  
CSA ratings  
KEMA 02 ATEX 2114 U<sup>1)</sup>  
Width  
Approvals

Field/factory wiring

Wire strip length

## WK 2,5/U

fine-stranded solid V A  
0.5-2.5 mm<sup>2</sup> 0.5-4 mm<sup>2</sup> 800V/8kV/3 24  
No. 22-12 AWG 600V 20/30  
No. 24-12 AWG 600V 25  
0.5-2.5 mm<sup>2</sup> 0.5-4 mm<sup>2</sup> 690V 23  
5mm 9mm

## WK 4/U

fine-stranded solid V A  
0.5-4 mm<sup>2</sup> 0.5-6 mm<sup>2</sup> 800V/8kV/3 32  
No. 22-10 AWG<sup>4)</sup> 600V 30/35  
No. 20-10 AWG 600V 40  
0.5-4 mm<sup>2</sup> 0.5-6 mm<sup>2</sup> 690V 14/27<sup>3)</sup>  
6mm 9mm

	Type	Part No.	Std. Pack	Type	Part No.	Std. Pack	
<b>Feed-through block</b>	gray	WK 2,5/U	57.503.0055.0	100	WK 4/U	57.504.0055.0	100
<b>Feed-through block Ex i</b>	blue	WK 2,5/U BLAU	57.503.0055.6	100	WK 4/U BLAU	57.504.0055.6	100
<b>Accessories</b>							
1. Mounting rail TS 35, DIN rail 7.5 mm high	L=2 m	35 x 27 x 7,5 EN 60715	98.300.0000.0	1	35 x 27 x 7,5 EN 60715	98.300.0000.0	1
Mounting rail TS 35, DIN rail, 15 mm high	L=2 m	35 x 27 x 15 EN 60715	98.370.0000.0	1	35 x 27 x 15 EN 60715	98.370.0000.0	1
Mounting rail TS 32, G rail <sup>2)</sup>	L=2 m	9006 EN 60715 G-32	98.190.0000.0	1	9006 EN 60715 G-32	98.190.0000.0	1
2. End clamp with U-foot <sup>2)</sup>	10 mm wide	WE 1/U	Z5.523.5753.0	100	WE 1/U	Z5.523.5753.0	100
End clamp TS 35, with screw	8 mm wide	9708/2 S35	Z5.522.8553.0	100	9708/2 S35	Z5.522.8553.0	100
End clamp TS 35, without screw	8 mm wide	WEF 1/35	Z5.523.9353.0	100	WEF 1/35	Z5.523.9353.0	100
3. End plate	gray	AP 2,5 - 4	07.311.0155.0	10	AP 2,5 - 4	07.311.0155.0	10
	blue	AP 2,5 - 4 BLAU	07.311.0155.6	10	AP 2,5 - 4 BLAU	07.311.0155.6	10
4. Partition	gray	TW 2,5 - 4	07.311.1155.0	10	TW 2,5 - 4	07.311.1155.0	10
5. Cross connector with screws	2 pole	IVB WK 2,5 - 2	Z7.280.2227.0	10	IVB WK 4 - 2	Z7.281.1227.0	10
insulated	3 pole	IVB WK 2,5 - 3	Z7.280.2327.0	10	IVB WK 4 - 3	Z7.281.1327.0	10
	up to 12 pole	IVB WK 2,5 - 12	Z7.280.3227.0	10	IVB WK 4 - 12	Z7.281.2227.0	10
6. Partition plate with marking facility		TS 2,5 GELB	07.311.2053.8	10	TS 4 GELB	07.311.2153.8	10
7. Single cover with marking facility		AD VB 2,5 GELB	04.326.2053.8	10	AD VB 4 GELB	04.326.2153.8	10
8. Cover with warning symbol over 4 blocks		AD VB 5/4 GELB	04.343.4756.8	10	AD VB 6/4 GELB	04.343.4856.8	10
For more accessories see pages 62-79							
For marking systems see pages 72-77							

<sup>\*)</sup> For maintaining the proper isolation distances, the open side of a feed-through terminal block as well as both sides of a jumper are to be enclosed by partitions.

<sup>1)</sup> Please note the mounting instructions.

<sup>2)</sup> Do not use in Ex environments.

<sup>3)</sup> With/without jumper