

HH4-LED 4" ARCHITECTURAL HIGH LUMEN LED DOWNLIGHT

SAME DAY
SHIPPING AVAILABLE

2000
LUMENS

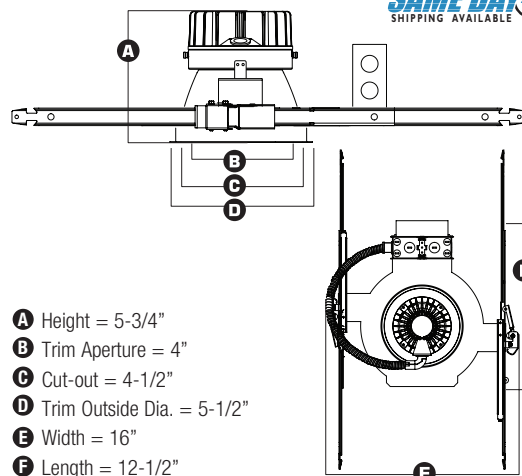
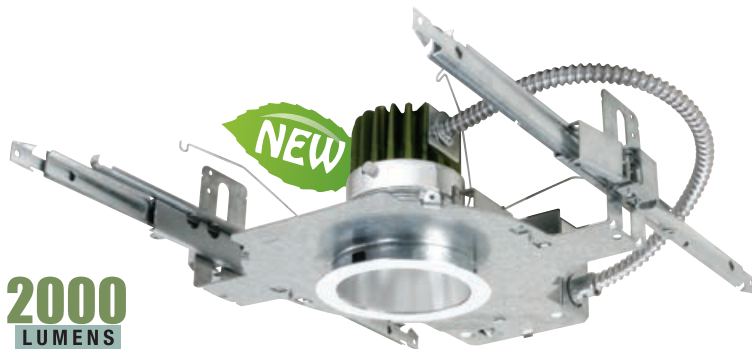

- A** Height = 5-3/4"
- B** Trim Aperture = 4"
- C** Cut-out = 4-1/2"
- D** Trim Outside Dia. = 5-1/2"
- E** Width = 16"
- F** Length = 12-1/2"

INPUT VOLT.	INPUT FREQ.	INPUT CUR.	THD	POWER FACTOR	INPUT POWER	LUMENS
120/277	50/60Hz	291mA/126mA	<20%	>0.9	35W(+/-5%)	2000
120/277	50/60Hz	200mA/86mA	<20%	>0.9	32W(+/-5%)	1500
120/277	50/60Hz	200mA/86mA	<20%	>0.9	20W(+/-5%)	1200
120/277	50/60Hz	150mA/65mA	<20%	>0.9	15W(+/-5%)	900

DESCRIPTION - 4" LED dedicated Architectural New Construction Downlight with integral LED heat management casting and driver (installed on junction box). Available in 900 lumens, 1200 lumens, 1500 lumens & 2000 lumens. ELITE's eco-friendly MAXILUME LED system is Energy Star and California Title 24 compliant and features 70% lumen maintenance at 50,000hrs of life. Our lighting adds comfort to any environment while using 50% less energy than the common CFL downlight.

FEATURES - MAXILUME LED luminaires are ideally suited for use in hospitality, health care, commercial, academic institutions, retail and other architectural applications.



OPTICS - MAXILUME LED Optilux technology combines unmatched performance with visual comfort. Spun 0.05" thick 1-step anodized reflector has been designed to gather the light scattered by the LED chip and shape it into functional beams that minimize brightness and glare, while eliminating lamp image. Reflector offers a 45-55 degree cutoff and smooth frost Solite diffuser distributes light even throughout the workplace in 3 different distribution; Wide (WD), Medium (MD) and Narrow (ND).

PERFORMANCE - Operating system delivers 900, 1200, 1500 & 2000 lumens. All MAXILUME LED luminaires are rated at 85+ and 90+ CRI, and are binned to within 3 MacAdam ellipses. Elite's highly selective LED chips produce zero ultraviolet and virtually no infrared light. All LED luminaires are rated and tested to LM-79 and LM-80 standards by an independent laboratory.

THERMAL MANAGEMENT SYSTEM - Using a proprietary coolLED Advanced Thermodynamic Design, Die-cast aluminum housing and heat management system are engineered for extremely long life and service period. Heat sink is attached to top of reflector. The LED light engine is attached to the die-cast heat sink and is easily replaceable and upgradable. Our die-cast system pulls the heat from the LED chip, allowing continued cool operation for years. Life tests have shown the MAXILUME light engine output will be maintained at 70% of initial at 50,000hrs of operation.

DIMMABLE - The MAXILUME LED system is shipped standard with a 0-10V driver which can be dimmed down to 1% of initial light output with a 0-10V dimmer when ordered with the following options (DIM10-120, DIM10-277). Fixtures can also be shipped with a Lutron Hi-lume A series driver which can be dimmed with Lutron Dimming Systems when ordered with the following options (LUTH-120, LUTH-277), Lutron® Hi-Lume A-Series (LUT2W-120) 2-Wire Forward Phase Control 1% Dimming in 120V only, or EldoLed 0-10V 1% Dimming, consult factory for other EldoLed driver and other driver options. Triac & Electronic Low Voltage dimming driver also available when ordered with the following options (DIMTR-120). All fixtures with 3000L and below are dimmable down to 1% and the fixtures with 4000L and above can be dimmed down to 10%.

MOUNTING FRAME - Die-formed construction for maximum heat dissipation and rust protection.

MOUNTING BRACKET - Constructed from 16 gauge steel and is supplied with C-channel that are adjustable up to 28". Mounting bracket maybe adjusted up to 2-3/4" vertically from inside the housing.

LED DRIVER/JUNCTION BOX - The LED driver is rated for 50 to 60Hz at 120V /277V input, produces less than 20%THD, and has a power factor between 90% and 100% and is thermally protected for additional safety. MAXILUME's LED driver is installed on the junction box cover so it may be serviced from below the ceiling. UL Listed for through-branch circuit wiring, provided with four 1/2" knockouts, one 3/4" knockout and four Romex knockouts with true pryout slots and strain clamps. Designed for straight through conduit runs.

OUR WORD - The MAXILUME LED lighting system carries a five-year carefree warranty for parts and components. (Labor not included.)

DIMMING INFORMATION

DIM10 (0-10V 1% Dimming)

LUTH (Lutron® Hi-Lume A-Series 3-Wire or Eco System 1% Dimming up to 4000 lumens only)

LUT2W (Lutron® Hi-Lume A-Series 2-Wire Forward Phase Control 1% Dimming in 120V only and up to 3000 lumens only)

ELDO10 (EldoLed 0-10V 1% Dimming up to 3000 lumens only, consult factory for the EldoLed driver options)

DIMTR (Triac & Electronic Low Voltage Dimming)

LISTING

c-UL-us / c-ETL-us - listed for Wet Location if used with HH4-4501 Trim.

c-UL-us / c-ETL-us - listed for feed Through Wiring.

LM79 / LM80

U.S Patent No. - D685,118S

CP - City of Chicago environmental air (CCEA) marking for plenum applications.

LED Driver options:

OPTOTRONIC OSRAM
Dimmable LED Power Supplies

LUTRON

PHILIPS ADVANCE
Quality LED Drivers

Example: HH4-LED-900L-DIM10-120-MD-30K-HH6-6501-CL-WH

TYPE	LUMENS/DRIVER				VOLTAGE	OPTICS	CCT	CRI	EMERGENCY	TRIM TYPE			REFLECTOR/RING FINISH	DISC
	900L SERIES	1200L SERIES	1500L SERIES	2000L SERIES						NO DISC	WITH DISC	DISC		
HH4-LED	<input type="checkbox"/> 900L-DIM10 <input type="checkbox"/> 900L-DIMTR 1 <input type="checkbox"/> 900L-LUTH 2 <input type="checkbox"/> 900L-LUT2W 1 <input type="checkbox"/> 900L-ELDO10-1 2 <input type="checkbox"/> 900L-ELDODALI -1 2 <input type="checkbox"/> 900L-ELDODMX -1 2	<input type="checkbox"/> 1200L-DIM10 <input type="checkbox"/> 1200L-DIMTR 1 <input type="checkbox"/> 1200L-LUTH 2 <input type="checkbox"/> 1200L-LUT2W 1 <input type="checkbox"/> 1200L-ELDO10-1 2 <input type="checkbox"/> 1200L-ELDODALI -1 2 <input type="checkbox"/> 1200L-ELDODMX -1 2	<input type="checkbox"/> 1500L-DIM10 <input type="checkbox"/> 1500L-DIMTR 1 <input type="checkbox"/> 1500L-LUTH 2 <input type="checkbox"/> 1500L-LUT2W 1 <input type="checkbox"/> 1500L-ELDO10-1 2 <input type="checkbox"/> 1500L-ELDODALI -1 2 <input type="checkbox"/> 1500L-ELDODMX -1 2	<input type="checkbox"/> 2000L-DIM10 <input type="checkbox"/> 2000L-DIMTR 1 <input type="checkbox"/> 2000L-LUTH 2 <input type="checkbox"/> 2000L-LUT2W 1 <input type="checkbox"/> 2000L-ELDO10-1 2 <input type="checkbox"/> 2000L-ELDODALI -1 2 <input type="checkbox"/> 2000L-ELDODMX -1 2	<input type="checkbox"/> 120 <input type="checkbox"/> 277 <input type="checkbox"/> 347 (DIM10 only)	<input type="checkbox"/> WD (60°-70°) <input type="checkbox"/> MD (50°-55°) <input type="checkbox"/> ND (30°-40°)	<input type="checkbox"/> 27K <input type="checkbox"/> 30K <input type="checkbox"/> 35K <input type="checkbox"/> 40K <input type="checkbox"/> 50K 2 (85+CRI only)	<input type="checkbox"/> 85+ <input type="checkbox"/> 90+	<input type="checkbox"/> EMG-LED Typical lumen output of the fixture is up to 1000L in emergency mode. Contact the factory for details. <input type="checkbox"/> OTHER OPTIONS <input type="checkbox"/> CP-CHICAGO-PLENUM	<input type="checkbox"/> HH4-4501 <input type="checkbox"/> HH4-4507 <input type="checkbox"/> HH4-4510 <input type="checkbox"/> HH4-4521 <input type="checkbox"/> HH4-4522 <input type="checkbox"/> HH4-4523 <input type="checkbox"/> HH4-4525 <input type="checkbox"/> HH4-4577	<input type="checkbox"/> HH4-4509 <input type="checkbox"/> CL-SCH <input type="checkbox"/> HH4-4511 <input type="checkbox"/> SHZ-4528	<input type="checkbox"/> CL-WH <input type="checkbox"/> CL-SCH <input type="checkbox"/> SHZ-SHZ <input type="checkbox"/> SHZ-WH <input type="checkbox"/> W-WH <input type="checkbox"/> MB-WH <input type="checkbox"/> WT-WH	<input type="checkbox"/> BLUE <input type="checkbox"/> RED <input type="checkbox"/> GREEN <input type="checkbox"/> FROST <input type="checkbox"/> AL <input type="checkbox"/> BZ <input type="checkbox"/> WH	

¹ LUT2W and DIMTR are available in 120V only ² LUTH, ELDO10-1, ELDODALI-1, and ELDODMX-1 are available in 120V and 277V ³ 50K series are available with 85+ CRI only

4" LED OPTICS



FOR
WET
LOCATION

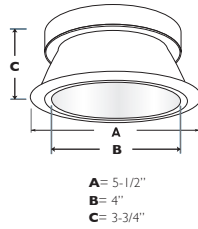

EXAMPLE: HH4-4501-CL-WH
HH4-4501 - REFLECTOR WITH DIFFUSE LENS
REFLECTOR/RING FINISH:
CL-WH CL-SCH WT-WH SHZ-WH W-WH SHZ-SHZ MB-WH
PATENT NO. D692,172

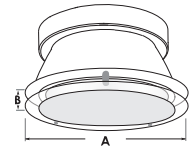
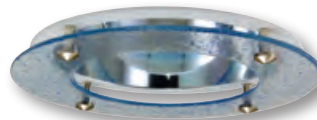

EXAMPLE: HH4-4521-CL-WH
HH4-4521 - STARDUST DECO RING GLASS WITH DIFFUSE LENS
REFLECTOR/RING FINISH:
CL-WH CL-SCH WT-WH SHZ-WH W-WH SHZ-SHZ MB-WH

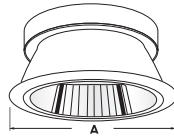

EXAMPLE: HH4-4507-CL-WH
HH4-4507 - WALL WASH REFLECTOR WITH DIFFUSE LENS
REFLECTOR/RING FINISH:
CL-WH CL-SCH WT-WH SHZ-WH W-WH SHZ-SHZ MB-WH
PATENT NO. D691,316

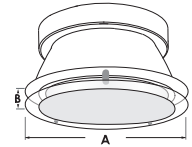

EXAMPLE: HH4-4523-CL-WH
HH4-4523 - PRISM DECO RING GLASS WITH DIFFUSE LENS
REFLECTOR/RING FINISH:
CL-WH CL-SCH WT-WH SHZ-WH W-WH SHZ-SHZ MB-WH

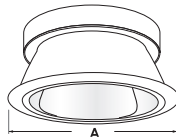

EXAMPLE: HH4-4577-CL-WH
HH4-4577 - DOUBLE WALL WASH REFLECTOR WITH DIFFUSE LENS
REFLECTOR/RING FINISH:
CL-WH CL-SCH WT-WH SHZ-WH W-WH SHZ-SHZ MB-WH

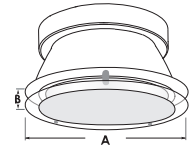

EXAMPLE: HH4-4522-CL-WH
HH4-4522 - EURO DECO RING GLASS WITH DIFFUSE LENS
REFLECTOR/RING FINISH:
CL-WH CL-SCH WT-WH SHZ-WH W-WH SHZ-SHZ MB-WH

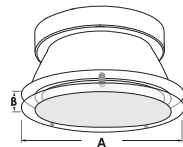

EXAMPLE: HH4-4509-CL-WH
HH4-4509 - DECO GLASS REFLECTOR WITH DIFFUSE LENS
REFLECTOR/RING FINISH:
CL-WH CL-SCH WT-WH SHZ-WH W-WH SHZ-SHZ MB-WH
GLASS FINISH:
BLUE, RED, GREEN, FROST

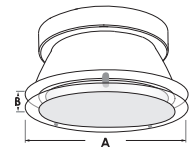

EXAMPLE: HH4-4525-CL-WH
HH4-4525 - CENTRAL ETCHED FLOAT GLASS WITH DIFFUSE LENS
REFLECTOR/RING FINISH:
CL-WH CL-SCH WT-WH SHZ-WH W-WH SHZ-SHZ MB-WH

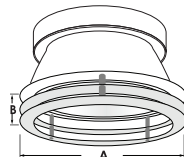

EXAMPLE: HH4-4510-CL-WH
HH4-4510 - DOUBLE RING GLASS WITH DIFFUSE LENS
REFLECTOR/RING FINISH:
CL-WH CL-SCH WT-WH SHZ-WH W-WH SHZ-SHZ MB-WH
GLASS FINISH:
BLUE, RED, GREEN, FROST

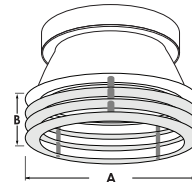

EXAMPLE: HH4-4511-CL-WH
HH4-4511 - TRIPLE RING GLASS WITH DIFFUSE LENS
REFLECTOR/RING FINISH:
CL-WH CL-SCH WT-WH SHZ-WH W-WH SHZ-SHZ MB-WH
GLASS FINISH:
BLUE, RED, GREEN, FROST



ALUMINIUM
DISC



HH4-4528-CL-W-WH



HH4-4528-CL-WH-BZ

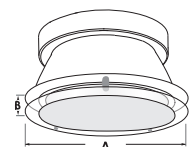

EXAMPLE: HH4-4528-CL-WH-AL
HH4-4528 - REFLECTOR WITH ALUMINIUM DISC AND DIFFUSE LENS
REFLECTOR FINISH:
CL-WH CL-SCH WT-WH SHZ-WH W-WH SHZ-SHZ MB-WH
DISC FINISH:
AL, WH, BZ

LED
4"

4 INCH ARCHITECTURAL HIGH LUMEN LED OPTICS

HH4-LED-2000L-DIM10-120-ND-85-40K-HH4-4501-SHZ-SHZ

INPUT WATTS: **34.8**

LUMENS: **1804**

CRI: **85+**

EFFICACY: **51.8**

CCT: **4000K**

TEST NO.: **EL-111362**

SPACING CRITERIA: **0.84**

Candle Power Distribution (Candelas)

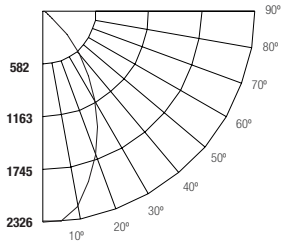

Zonal Lumens Summary

Zone	Lumens	%Lamp	%Fixt
0-20	702.75	39.00	38.90
0-30	1256.51	69.80	69.60
0-40	1566.59	87.00	86.80
0-60	1777.33	98.70	98.50
0-80	1802.1	100.10	99.90
0-90	1804.34	100.20	100.00

Luminance (Average candela/M²)

Angle in Degrees	Average		
	0°	45°	90°
45	58280	34487	30056
55	18168	15750	10868
65	9788	6176	3686
75	3245	2701	1555
85	6073	4775	765

Lumens Per Zone

Zone	Lumens
0-10	205.86
10-20	496.89
20-30	553.76
30-40	310.08
40-50	154.09
50-60	56.66
60-70	19.82
70-80	4.95
80-90	2.24

Candela Tabulation

0	1	2	3	4	5	6	7	8	9
0	2326	2294	1883	1311	767	327	82	32	6
1	5	15	25	35	45	55	65	75	85
2	5	15	25	35	45	55	65	75	85
3	5	15	25	35	45	55	65	75	85
4	5	15	25	35	45	55	65	75	85
5	5	15	25	35	45	55	65	75	85
6	5	15	25	35	45	55	65	75	85
7	5	15	25	35	45	55	65	75	85
8	5	15	25	35	45	55	65	75	85
9	5	15	25	35	45	55	65	75	85

Coefficients of Utilization - Zonal Cavity Method

Effective Floor Cavity Reflectance 0.20

ROOM CAVITY RATIO	RC		80%				70%				50%				30%				10%				0%			
	0	1	120	120	120	120	117	117	117	117	112	112	112	107	107	107	103	103	103	103	101	101	101	101		
0	0	119	119	119	119	117	117	117	117	111	111	111	107	107	107	102	102	102	100	100	100	100	100	100		
1	1	114	111	108	106	111	108	106	104	104	103	101	101	99	98	97	96	95	93	93	93	93	93	93		
2	2	108	103	98	95	105	101	97	94	98	94	92	95	92	90	92	90	88	86	86	86	86	86	86		
3	3	102	95	90	86	100	94	89	85	91	87	84	89	86	83	87	84	81	80	80	80	80	80	80		
4	4	97	89	83	79	95	88	82	78	86	81	77	84	80	77	82	78	76	74	74	74	74	74	74		
5	5	92	83	77	73	90	82	77	72	80	75	72	79	74	71	77	73	70	69	69	69	69	69	69		
6	6	87	78	72	67	86	77	71	67	76	70	67	74	70	66	73	69	66	64	64	64	64	64	64		
7	7	83	73	67	63	81	73	67	63	71	66	62	70	65	62	69	65	62	60	60	60	60	60	60		
8	8	79	69	63	59	77	68	63	59	67	62	58	66	62	58	65	61	58	56	56	56	56	56	56		
9	9	75	65	59	55	74	65	59	55	64	58	55	63	58	55	62	58	54	53	53	53	53	53	53		
10	10	71	62	56	52	70	61	56	52	60	55	52	60	55	51	59	54	51	50	50	50	50	50	50		

RC - Ceiling Cavity Reflectance

RW - Wall Reflectance

Cone of Light		
4.0	145.4	3.9'
8.0	36.4	7.7'
12.0	16.2	11.9'
16.0	9.1	15.8'
20.0	5.8	19.8'

Distance to Plane | Initial Footcandle at Nadir | Beam diameter

BEAM DIA. MEASURED AT 50% OF NADIR F.C.

HH4-LED-1500L-DIM10-120-ND-85-40K-HH4-4501-SHZ-SHZ

INPUT WATTS: **31.7**

LUMENS: **1564**

CRI: **85+**

EFFICACY: **49.3**

CCT: **4000K**

TEST NO.: **EL-091365**

SPACING CRITERIA: **0.88**

Candle Power Distribution (Candelas)

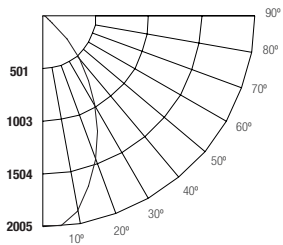

Zonal Lumens Summary

Zone	Lumens	%Lamp	%Fixt
0-20	607.83	39.20	38.90
0-30	1082.42	69.80	69.20
0-40	1356.7	87.50	86.70
0-60	1540.53	99.30	98.50
0-80	1562.19	100.70	99.90
0-90	1563.95	100.80	100.00

Luminance (Average candela/M²)

Angle in Degrees	Average		
	0°	45°	90°
45	57691	30561	23951
55	18253	14275	8801
65	9764	5742	2942
75	3007	2317	1239
85	4862	3578	563

Lumens Per Zone

Zone	Lumens
0-10	177.76
10-20	430.07
20-30	474.59
30-40	274.27
40-50	133.82
50-60	50.01
60-70	17.34
70-80	4.33
80-90	1.76

Candela Tabulation

0	1	2	3	4	5	6	7	8	9
0	1997	2005	1676	1216	756	324	83	32	6
1	5	15	25	35	45	55	65	75	85
2	5	15	25	35	45	55	65	75	85
3	5	15	25	35	45	55	65	75	85
4	5	15	25	35	45	55	65	75	85
5	5	15	25	35	45	55	65	75	85
6	5	15	25	35	45	55	65	75	85
7	5	15	25	35	45	55	65	75	85
8	5	15	25	35	45	55	65	75	85
9	5	15	25	35	45	55	65	75	85

Coefficients of Utilization - Zonal Cavity Method

Effective Floor Cavity Reflectance 0.20

ROOM CAVITY RATIO	RC		80%				70%				50%				30%				10%				0%			
	0	1	120	120	120	120	117	117	117	117	112	112	112	107	107	107	103	103	103	103	101	101	101	101		
0	0	120	120	120	120	117	117	117	117	112	112	112	107	107	107	103	103	103	101	101	101	101	101	101		
1	1	114	111	109	106	112	109	107	105	105	103	101	101	100	98	98	97	96	94	94	94	94	94	94		
2	2	108	103	99	95	106	101	98	94	98	95	92	95	93	90	92	90	88	87	87	87	87	87	87		
3	3	103	96	91	87	101	95	90	86	92	88	85	89	86	83	87	84	82	80	80	80	80	80	80		
4	4	97	89	84	79	95	88	83	79	86	81	78	84	80	77	82	79	76	74	74	74	74	74	74		
5	5	92	84	78	73	91	83	77	73	81	76	72	79	75	71	77	74	71	69	69	69	69	69	69		
6	6	88	78	72	68	86	77	72	67	76	71	67	75	70	67	73	69	66	65	65	65	65	65	65		
7	7	83	74	67	63	82	73	67	63	72	66	63	70	66	62	69	65	62	60	60	60	60	60	60		
8	8	79	69	63	59	78	69	63	59	68	62	59	67	62	58	66	61	58	57	57	57	57	57	57		
9	9	75	65	59	55	74	65	59	55	64	59	55	63	58	55	62	58	55	53	53	53	53	53	53		
10	10	72	62	56	52	71	62	56	52	61	55	52	60	55	52	59	55	52	50	50	50	50	50	50		

RC - Ceiling Cavity Reflectance

RW - Wall Reflectance

Cone of Light		
4.0	124.9	4.0'
8.0	31.2	7.9'
12.0	13.9	11.9'
16.0	7.8	15.8'
20.0	5.0	19.8'

Distance to Plane | Initial Footcandle at Nadir | Beam diameter

BEAM DIA. MEASURED AT 50% OF NADIR F.C.

HH4-LED-1200L-DIM10-120-ND-40K-HH4-4501-SHZ-SHZ

INPUT WATTS: **23.8**

LUMENS: **1137**

CRI: **85+**

EFFICACY: **47.8**

CCT: **4000K**

TEST NO.: **EL-091360**

SPACING CRITERIA: **0.82**

Candle Power Distribution (Candelas)

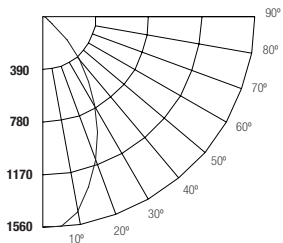

Zonal Lumens Summary

Zone	Lumens	%Lamp	%Fixt
0-20	449.67	39.90	39.60
0-30	791.91	70.30	69.70
0-40	984.60	87.40	86.60
0-60	1118.99	99.40	98.50
0-80	1135.18	100.80	99.90
0-90	1136.52	100.90	100.00

Luminance (Average candela/M²)

Angle in Degrees	Average		
	0°	45°	90°
45	42863	22502	17107
55	14299	10487	5951
65	7649	415	

4" LED PHOTOMETRY

HH4-LED-2000L-DIM10-120-WD-85-40K-HH4-4501-SHZ-SHZ

INPUT WATTS: 35.7

LUMENS: 1586

CRI: 85+

EFFICACY: 44.4

CCT: 4000K

TEST NO.: EL-111373

SPACING CRITERIA: 1.02

Candle Power Distribution (Candelas)

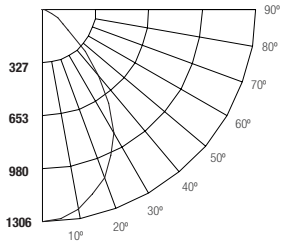

Zonal Lumens Summary

Zone	Lumens	%Lamp	%Fixt
0-20	458.43	28.90	28.90
0-30	904.12	57.10	57.00
0-40	1276.61	80.60	80.50
0-60	1553.06	98.00	97.90
0-80	1583.7	100.00	99.90
0-90	1585.97	100.10	100.00

Luminance (Average candela/M²)

Angle in Degrees	Average		
	0°	45°	90°
45	55115	47328	40043
55	23497	20165	13179
65	12656	7732	4201
75	4003	3012	1705
85	6174	4386	822

Lumens Per Zone

Zone	Lumens
0-10	122.29
10-20	336.14
20-30	445.69
30-40	372.49
40-50	203.93
50-60	72.52
60-70	24.76
70-80	5.87
80-90	2.27

Candela Tabulation

0	1306
0	1306
5	1286
15	1175
25	962
35	650
45	309
55	107
65	42
75	8
85	4
90	2

Cone of Light		
4.0	81.7'	5.6'
8.0	20.4	11.2'
12.0	9.1	16.8'
16.0	5.1	22.4'
20.0	3.3	27.9'
Distance to Plane	Initial Footcandle at Nadir	Beam diameter

BEAM DIA. MEASURED AT 50% OF NADIR F.C.

Coefficients of Utilization - Zonal Cavity Method

Effective Floor Cavity Reflectance 0.20

ROOM CAVITY RATIO	RC		80%				70%				50%				30%				10%				0%			
	RW	70%	50%	30%	10%	70%	50%	30%	10%	50%	30%	10%	50%	30%	10%	50%	30%	10%	50%	30%	10%	0%				
0	1	119	119	119	119	116	116	116	116	111	111	111	107	107	107	102	102	102	100							
1	113	110	107	104		110	108	105	103	103	101	100	100	98	97	96	95	94	92							
2	106	101	96	92		104	99	95	91	96	92	89	93	90	87	90	88	86	84							
3	100	93	87	83		98	91	86	82	89	84	81	86	82	79	84	81	78	76							
4	94	86	79	74		92	84	78	74	82	77	73	80	76	72	78	74	71	70							
5	89	79	72	68		87	78	72	67	76	71	67	74	70	66	73	69	65	64							
6	83	73	67	62		82	72	66	62	71	65	61	69	64	61	68	64	60	59							
7	79	68	61	57		77	67	61	57	66	60	56	65	60	56	64	59	56	54							
8	74	64	57	52		73	63	57	52	62	56	52	61	56	52	60	55	51	50							
9	70	59	53	48		69	59	53	48	58	52	48	57	52	48	56	51	48	46							
10	67	56	49	45		65	55	49	45	54	49	45	54	48	45	53	48	45	43							

RC - Ceiling Cavity Reflectance

RW - Wall Reflectance

HH4-LED-2000L-DIM10-120-MD-85-40K-HH4-4501-SHZ-SHZ

INPUT WATTS: 34.8

LUMENS: 1763

CRI: 85+

EFFICACY: 50.7

CCT: 4000K

TEST NO.: EL-111369

SPACING CRITERIA: 0.92

Candle Power Distribution (Candelas)

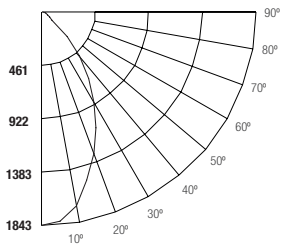

Zonal Lumens Summary

Zone	Lumens	%Lamp	%Fixt
0-20	600.29	34.10	34.10
0-30	1112.17	63.20	63.10
0-40	1471.66	83.60	83.50
0-60	1730.88	98.30	98.20
0-80	1760.52	100.00	99.90
0-90	1762.94	100.20	100.00

Luminance (Average candela/M²)

Angle in Degrees	Average		
	0°	45°	90°
45	60936	44961	37186
55	23641	19319	12032
65	12638	7101	3939
75	3901	2949	1661
85	6477	4804	822

Lumens Per Zone

Zone	Lumens
0-10	168.31
10-20	431.98
20-30	511.87
30-40	359.49
40-50	190.44
50-60	68.78
60-70	23.82
70-80	5.83
80-90	2.42

Candela Tabulation

0	1843
0	1843
5	1818
15	1587
25	1193
35	747
45	342
55	107
65	42
75	8
85	4
90	2

Cone of Light		
4.0	115.2'	4.5'
8.0	28.8	8.9'
12.0	12.8	13.5'
16.0	7.2	17.8'
20.0	4.6	22.3'
Distance to Plane	Initial Footcandle at Nadir	Beam diameter

BEAM DIA. MEASURED AT 50% OF NADIR F.C.

Coefficients of Utilization - Zonal Cavity Method

Effective Floor Cavity Reflectance 0.20

ROOM CAVITY RATIO	RC		80%				70%				50%				30%				10%				0%			
	RW	70%	50%	30%	10%	70%	50%	30%	10%	50%	30%	10%	50%	30%	10%	50%	30%	10%	50%	30%	10%	0%				
0	1	119	119	119	119	116	116	116	116	111	111	111	107	107	107	102	102	102	100							
1	113	110	107	105		111	108	106	103	104	102	100	100	99	97	97	96	94	93							
2	107	102	97	94		105	100	96	93	97	93	91	94	91	89	91	89	87	85							
3	101	94	89	84		99	93	88	84	90	86	82	87	84	81	85	82	80	78							
4	95	87	81	77		93	86	80	76	84	79	75	82	78	74	80	76	73	72							
5	90	81	75	70		88	80	74	70	78	73	69	77	72	68	75	71	68	66							
6	85	76	69	64		84	75	69	64	73	68	64	72	67	63	70	66	63	61							
7	81	71	64	60		79	70	64	59	69	63	59	67	62	59	66	62	59	57							
8	76	66	60	55		75	66	60	55	65	59	55	63	58	55	62	58	55	53							
9	73	62	56	52		71	62	56	52	61	55	51	60	55	51	59	54	51	50							
10	69	59	53	48		68	58	52	48	57	52	48	57	52	48	56	51	48	47							

RC - Ceiling Cavity Reflectance

RW - Wall Reflectance

HH4-LED-2000L-DIM10-120-ND-85-40K-HH4-4501-CL-SCH

INPUT WATTS: 34.8

LUMENS: 1939

CRI: 85+

EFFICACY: 55.7

CCT: 4000K

TEST NO.: EL-111361

SPACING CRITERIA: 0.86

Candle Power Distribution (Candelas)

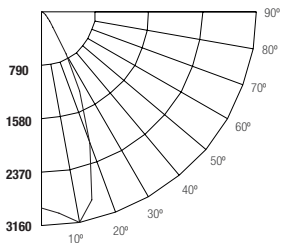

Zonal Lumens Summary

Zone	Lumens	%Lamp	%Fixt
0-20	976.94	50.50	50.40
0-30	1550.28	80.10	79.90
0-40	1789.48	92.50	92.30
0-60	1927.36	99.60	99.40
0-80	1937.65	100.10	99.90
0-90	1939.34	100.20	100.00

Luminance (Average candela/M²)

Angle in Degrees	Average		
	0°	45°	90°
45	47188	22851	20873
55	12878	7944	3788
65	6498	1535	1086
75	1691	1151	510
85	5266	4227	231

Lumens Per Zone

Zone	Lumens
0-10	276.42
10-20	700.52
20-30	573.34
30-40	239.20
40-50	108.21
50-60	29.67
60-70	8.27
70-80	2.02
80-90	1.69

Candela Tabulation

0	2722
0	2722
5	2858
15	2639
25	1478
35	641
45	265
55	58
65	21
75	3
85	3
90	3

Cone of Light		
4.0	170.2'	3.4'
8.0	42.5	6.7'
12.0	18.9	10.1'
16.0	10.6	13.5'
20.0	6.8	16.9'
Distance to Plane	Initial Footcandle at Nadir	Beam diameter

BEAM DIA. MEASURED AT 50% OF NADIR F.C.

Coefficients of Utilization - Zonal Cavity Method

Effective Floor Cavity Reflectance 0.20

ROOM CAVITY RATIO	RC		80%				70%				50%				30%				10%				0%			
	RW	70%	50%	30%	10%	70%	50%	30%	10%	50%	30%	10%	50%	30%	10%	50%	30%	10%	50%	30%	10%	0%				
0	1	119	119	119	119	117	117	117	117	111	111	111	107	107	107	102	102	102	100							
1	114	111	109	107		112	109	107	105	105	104	102	102	100	99	98	97	96	94							
2	109	104	100	97		107	103	99	96	99	97	94	96	94	92	94	92	90	89							
3	104	98	93	89		102																				