

Composite Inground (IL336) Specification Sheet

Project Name:	Location:	MFG: Philips Hadco
Fixture Type:	Catalog No.:	Qty:

Ordering Guide

Example: IL336 A L

Product Code	IL336	Composite Inground
Finish	A	Black
Lamp	L	Lamp *1

*1 Lamp is optional. Adding "L" at the end of the fixture coding means a 20W lamp will be provided with the fixture.

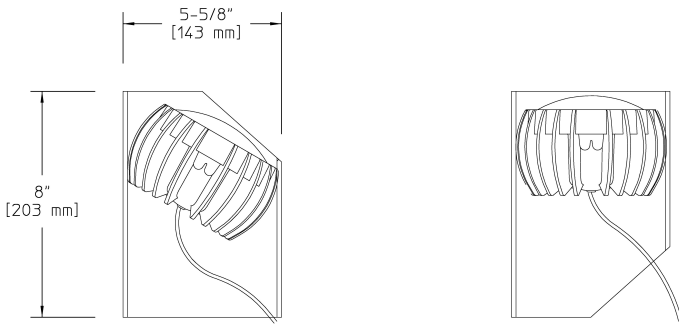

Specifications

HOUSING:

Single-piece PVC tube. Straight cut end allows flush ground mounting, and an accessory lens guard or rock guard may be ordered separately, but is not required. Angled cut end requires the top 3" installed above ground for maximum vertical spot aiming with shielding being provided on three (3) sides. Patented Lamp Holder - Durable silicone rubber lamp holder has integral fins to allow the height and angle of the lamp to be adjusted without any mechanical moving parts. Fixture offers 360° lamp rotation and up to 45° off vertical aiming adjustability, restricted only by the cutoff of the housing.

LAMPING:

50W maximum PAR36 screw terminal lamp. 20W PAR36 lamp is included with fixture. Lower wattage lamps are acceptable.

ELECTRICAL ASSEMBLY:

Double screw terminal socket. 12 Volt fixture is pre-wired with 3-ft pigtail of 18-2 AWG, 105° C, SPT-1W wire. Low voltage quick connector, catalog #LVC3 included for easy hook-up to the low voltage supply cable, not included. 12 Volt system requires remote transformer, not included.

WARRANTY:

Ten-year limited warranty.

CERTIFICATIONS:

ETL listed to U.S. safety standards for wet locations. cETL listed to Canadian safety standards for wet locations. Manufactured to ISO 9001:2008 Standards.

Height :

8" (203mm)

Width:

5 5/8 (143mm)

Max. Weight:

3.04 lb