

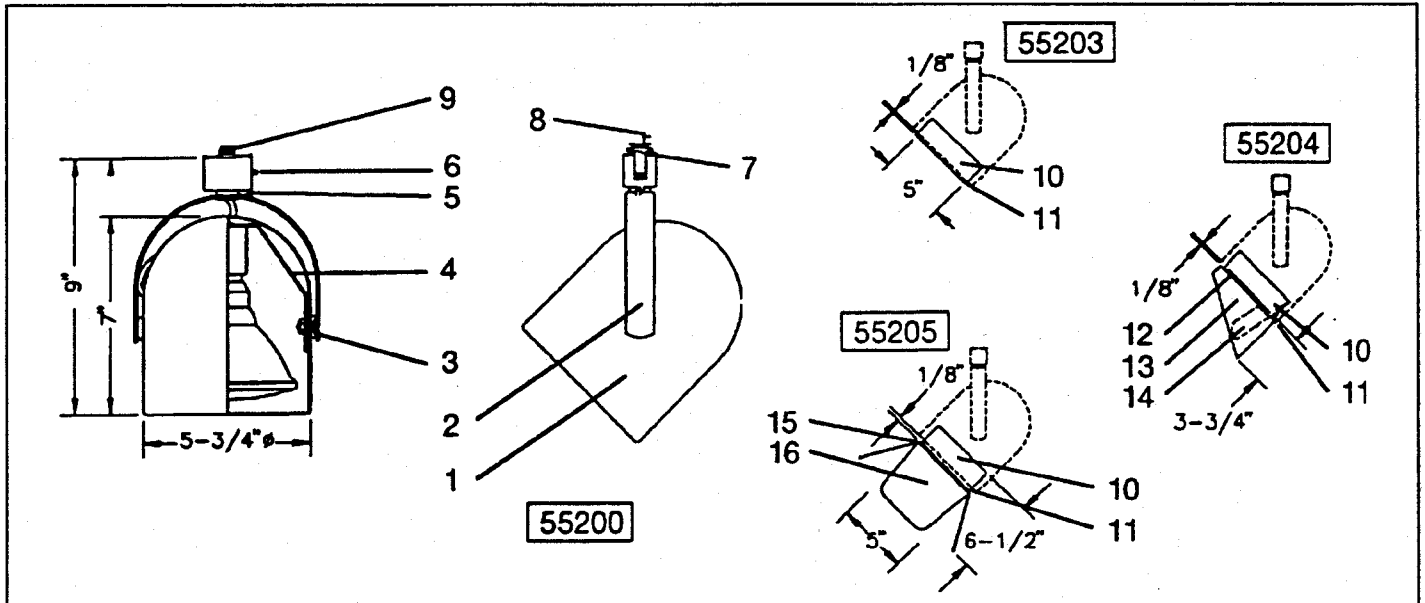

LIMELITE - VERSALYTE  
INCANDESCENT - HALOGEN

LYTESPAN  
TRACK LIGHTING SYSTEM

55200



#### Ordering Information

Cat. No.	Finish	Description	Lamps
55200WH	WHITE	LYTESPOT	300W PAR-40 250W PAR-38
55200BK	BLACK		
55203WH	WHITE	Accessory holder *	250W PAR-38 (PAR-38 lamp only)
55203BK	BLACK		
55204WH	WHITE	Wall washer accessory	
55204BK	BLACK		
55205WH	WHITE	Barn doors accessory holder *	
55205BK	BLACK		

\* Maximum of 2 accessories may be used.

#### FEATURES

- 1- HOUSING: .040": aluminum.
- 2- YOKE: .093" steel.
- 3- TRUNION MOUNTING: tensioned with internal spring washer and vibration-resistant unit.
- 4- SOCKET SUPPORT: .093" steel.
- 5- PIVOT MOUNTING: permanently tensioned; 350 deg. stop.
- 6- PUSH TAB: molded polycarbonate. Detaches unit.
- 7- POLARITY KEYWAY
- 8- MOVABLE BRASS CONTACT: extends for connection to 2<sup>nd</sup> circuit in Advent Lytespan track.
- 9- LYTESPAN ATTACHMENT FITTING: molded polycarbonate integral color. Fitter twists onto track, locks on with push tab.
- 10- ACCESSORY HOLDER: .032" steel.
- 11- SPRING CLIPS: .020" stainless steel.
- 12- BEAM ELONGATOR: molded, one-piece heat resistant Borosilicate glass; parallel ribs on one side to redirect and spread light; fine stippling, on other side to break up filament image.
- 13- WALL WASHER SHIELD: .030" steel.
- 14- REFLECTOR: embossed anodized clear aluminum.
- 15- HINGE: permanently tensioned.
- 16- DOOR (4): 0.36" steel.

#### ELECTRICAL

ELECTRICAL: porcelain socket, medium base nickel plated screw shell. No. 18 SEW-1 leads.

#### OPTION & ACCESSORIES

4 3/4" color filters, heat filters, spread lens, louver (see Lightolier specification sheet 7560).

#### FINISH

FINISH: all painted finished baked enamel.

#### LABELS

LABELS: CSA