

METAL HALIDE

(60 Hz., MINIMUM STARTING TEMPERATURE -20°F OR -30°C)

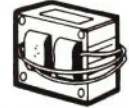

Input Volts	Catalog † Number	Circuit Type	Watts Input	Max Input Current	Nom Open Circuit Voltage	Fuse Rating (Amps)	Wiring Dia	Dimensions			Non-PCB Capacitor (Page 158-159)				Total Weight (lbs)	Ignitor †† (Page 160-163)		U.L. Bench Top Rise Code 1029 (pg 115)			
											Mfd	Min Volt	Dry Film			Oil Filled			Part Number	Max Dist To Lamp (ft)	
								Fig	A	B			Dia (in)	Ht (in)		Oval (in)	Ht (in)				
250 Watt Lamp, ANSI Code M58 or H37																					
120	71A5700	CWA	295	2.5	300	8	A	2	1.5	3.0	15	400	1.75	3.75	—	—	9.0	—	A		
208	71A5710			1.4	310	5			1.7	3.1										10.0	B
240	71A5720			1.3	310	5			1.7	3.1										10.0	A
277	71A5730			1.1	300	3			1.5	3.0										9.0	A
480	71A5740 71A5740-001D	CWA	295	.7	315	2	A	2	1.7	3.1	15	400	1.75	3.75	—	—	10.0	—	B		
480/120T	71A5740-T	CWA	295	.7	315	2	A	2	1.7	3.1	15	400	1.75	3.75	—	—	10.0	—	B		
120/277	71A5780	CWA	295	2.5/1.1	300	8/3	A	2	1.5	3.0	15	400	1.75	3.75	—	—	9.0	—	A/A		
127/220	71A57H0	CWA	295	2.6/1.5	300	8/5	A	2	1.5	3.0	15	400	1.75	3.75	—	—	9.0	—	A/B		
120/208/ 240/277	71A5790	CWA	295	2.5/1.4 1.3/1.1	300	8/5/ 5/3	A	2	1.5	3.0	15	400	1.75	3.75	—	—	9.0	—	A/A/ B/A		
120/208/ 240/277	71A5770-001D	CWA	295	2.5/1.4 1.3/1.1	300	8/5/ 5/3	A	2	1.5	3.0	15	400	1.75	3.75	—	—	9.0	—	A/A B/A		
120/ 277/347	71A57A0	CWA	295	2.5/ 1.1/.9	315	8/ 3/3	A	2	1.7	3.1	15	400	1.75	3.75	—	—	10.0	—	A/ A/A		
120/ 277/347	71A57A0-001D	CWA	295	2.5/ 1.1/.9	315	8/ 3/3	A	2	1.7	3.1	15	400	1.75	3.75	—	—	10.0	—	A/ A/A		
120	71A5701 ♦	CWA	294	2.6	300	8	A	1	3.0	4.2	15	400	1.75	3.75	—	—	9.0	—	C		
208	71A5711 ♦			1.5		5														F	
240	71A5721 ♦			1.3		5														G	
277	71A5731 ♦			1.1		3														D	
480	71A5741 ♦ 71A5741-001D	CWA	298	.7	300	2	A	1	3.0	4.2	15	400	1.75	3.75	—	—	9.0	—	H		
120/208/ 240/277	71A5791 ♦	CWA	294	2.6/1.5/ 1.3/1.1	300	8/5/ 5/3	A	1	3.0	4.2	15	400	1.75	3.75	—	—	9.0	—	C/C/ D/D		
120/208/ 240/277	71A5771-001D ♦	CWA	294	2.6/1.5/ 1.3/1.1	300	8/5/ 5/3	A	1	3.0	4.2	15	400	1.75	3.75	—	—	9.0	—	C/C/ D/D		
120/ 208/240	71A57E6	CWI	295	2.6/ 1.5/1.3	310	7/ 4/4	P	2	1.8	3.3	13	425	—	—	1.75	3.75	11.0	—	E/ D/D		



HID • CORE & COIL METAL HALIDE

† Ordering information:

Replacement/retrofit ballast kits indicated by **bold type** with suffix **-001D**.

Refer to pages 117-120.

Original equipment ballasts - add proper suffix to catalog number:

- 500D includes core & coil with dry-film capacitor
- 510D includes core & coil with welded bracket and dry-film capacitor
- 500 includes core & coil with oil-filled capacitor
- 510 includes core & coil with welded bracket and oil-filled capacitor
- 600 core & coil only (no capacitor)
- 610 core & coil with welded bracket (no capacitor)

• For CWA and CWI circuits, figure is operating current.

†† Each ballast requiring an ignitor is furnished standard with the **Short Range** ignitor model shown for use within fixtures. If a **Long Range** ignitor is required for remote mounting, specify on order. See pages 160-163 for additional information.

♦ Special compact 3 x 4 core design. Note Bench Top Rise Codes in last column.

♣ Canadian replacement/retrofit ballast kit indicated by **bold type**. Refer to pages 121-122.

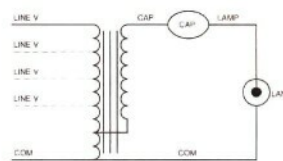

Fig A

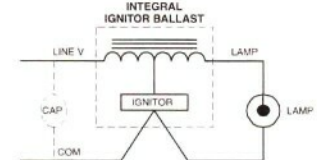

Fig H

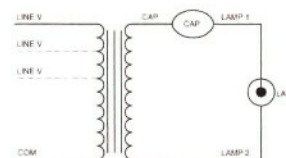

Fig P



HIGH INTENSITY DISCHARGE BALLASTS

Encapsulated Core & Coil

Where quiet performance is required, the standard open core & coil ballasts are encapsulated (potted) in a cube-shaped steel can utilizing Class H (180°C) polyester compound. These ballasts carry a Class A noise rating up through 175 watts and Class B for 250 and 400 watts. As with the open core & coil, the capacitor (and ignitor where included) are mounted separately within the fixture.

Fluorescent Can (F-Can)

For indoor commercial applications of HID lighting such as offices, schools and retail stores, ballast noise must be minimized. Ballasts for these fixtures are most often encased and potted in fluorescent ballast type cans and utilize Class A (90°C) asphalt insulating materials (the same as used in fluorescent lamp ballasts).

The Advance line of F-can ballasts comes in two dual-voltage configurations: 120/277 volt for the US market, and 120/347 volt for the Canadian market. Each unit has built-in, automatically resetting, thermal protectors which disconnect the ballast from the power line in the event of overheating. All units are high power factor and include the capacitor within the can. All models for high pressure sodium and low-wattage metal halide lamps also include the ignitor in the can.

Indoor Enclosed

These units are designed for use indoors where the ballast must be mounted remotely from the luminaire. They are most typically used in factories where the luminaire may be mounted in a high-bay where very high ambient temperatures may be experienced. In these instances, the remotely-mounted ballast operates cooler, subsequently providing longer life because it is away from both the heat of the ceiling ambient and lamp heat within the fixture.

The case contains the core & coil potted in a Class H (180°C) heat-dissipating resin. The capacitor(s) and ignitor are contained within a separate compartment. Knockouts in both ends of the case facilitate hook-up in the most convenient manner. Wall mounting is accomplished through flanges on the top and bottom of the case. The ballast is a UL Listed product.

Outdoor Weatherproof

Weatherproof ballasts are designed for remote, pole-mounting outdoor applications under all weather conditions. They may also be placed inside of a transformer pole base, but care must be taken to avoid areas prone to flooding because weatherproof ballasts are not water-submersible.

The core & coil with its capacitor and ignitor (where required) are firmly mounted to the heat-sink base. An aluminum cover is placed over the core-&-coil assembly and is bolted with a weather-tight gasket to the base. An integral 1" threaded nipple with locknut facilities hook-up to electrical conduit or to the mounting bracket when used on a pole. The weatherproof ballast may also be placed nipple-up, with a drip loop in the leads, inside a pole base.

Postline

Lantern-type fixtures mounted on slender poles often require ballasts which will fit into these poles. Special, elongated core & coil ballasts are potted in resin in cylindrical cans having a 2.55" outside diameter. All include leads necessary for direct connection to a photocell.

The capacitor and ignitor (where required) are included within this can. A 1/2" threaded nipple is used for vertical mounting, and leads extend from both ends of the can for ease of installation. The input leads to the ballast also provide for proper connection to the photocell if such is included within the fixture.

To help prevent overheating, one to three feet of air space should be allowed in the pole above the ballast, and the ballast should be positioned against the post interior wall to provide a heat-sink. All units rated 100W and above now include a mounting kit consisting of an 18" chain to hang the ballast within the pole and a spring clip to force the ballast's cylindrical can to make line contact with the pole's interior surface to maximize heat transfer, thus prolonging the ballast life.

BALLAST DATE AND TEMPERATURE CODES

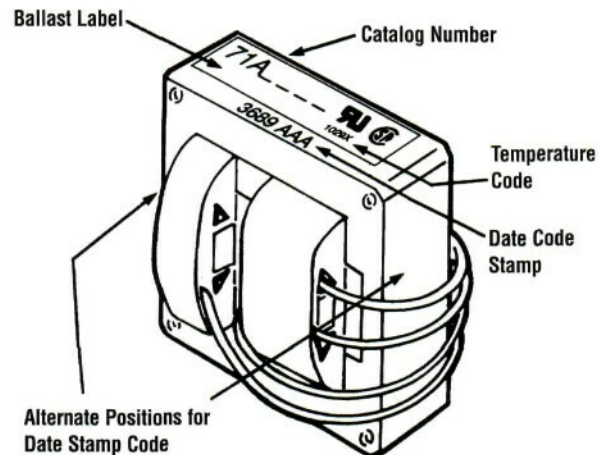

ADVANCE® HID Core & Coil ballasts are date stamped on either the top surface or the side surface of the ballast core. The four-digit number represents the *week* and *year* of manufacture. The first two numbers indicate the week and the last two indicate the year the ballast was manufactured. The example shows a ballast manufactured during the 36th week of 1989. The three letters are an Advance factory code.

The ballast's UL Bench Top Rise Temperature Code is shown on the label (see below).

UL BENCH TOP RISE TEMPERATURE CODE

To facilitate UL inspection, each ballast's UL Bench Top Rise Temperature Code is shown on the Advance Core & Coil ballast label as 1029X, where 1029 is the UL Standard for HID Ballasts, and the X is the temperature code: A, B, C, etc. If a fixture is UL listed for 1029C, then automatically, all ballasts with an A, B, or C temperature classification are acceptable for use within that same fixture.

UL Bench Top Rise Letter Code	Temperature Range for Class H (180°C) Ballasts
A	less than 75°C
B	75°C < 80°C
C	80°C < 85°C
D	85°C < 90°C
E	90°C < 95°C
F	95°C < 100°C
etc.	etc.

CERTIFICATIONS



Indicates ballast is listed by Underwriters Laboratories, Inc. in accordance with UL 1029 Standard for HID Ballasts. Each ballast is marked appropriately.



Indicates ballast is component recognized by Underwriters Laboratories, Inc. in accordance with UL 1029 Standard for HID Ballasts. Each ballast is marked appropriately.



Indicates ballast is certified by Canadian Standards Association in accordance with CAN/CSA-22.2 No. 74-92. Each ballast is marked appropriately.



All HID Ballasts are designed and manufactured in accordance with the American National Standards Institute Standard for HID Ballasts, ANSI C82.4.

ORDERING INFORMATION

How to Order

Advance Transformer has developed the industry's broadest selection of HID ballasts. More than 3000 stocking distributors nationwide. For information on the distributor best able to serve your needs, please call 800-372-3331.

Advance HID Ballast Part Number Explanation

71A	60	9	1	-500D							
<p>Suffix Code* (as applicable)</p> <ul style="list-style-type: none"> -001D ballast replacement kit with dry film capacitor -001 ballast replacement kit with oil filled capacitor -500D core & coil ballast with dry film capacitor -500 core & coil ballast with oil filled capacitor -510D core & coil ballast with welded bracket and dry film capacitor -510 core & coil ballast with welded bracket and oil filled capacitor -540D core & coil ballast with welded angle bracket and dry film capacitor -600 core & coil ballast (no capacitor) -610 core & coil ballast with welded bracket (no capacitor) <p>* Add additional feature codes to the end of suffix where applicable. i.e. -B = Integral Ignitor, -P = Thermally Protected, -J = J-Box Mounting</p>											
Design Code											
<table style="width: 100%; border: none;"> <tr> <td style="width: 30%;"></td> <td style="text-align: center;">60 Hz Voltages</td> <td style="text-align: center;">50 Hz Voltages</td> </tr> <tr> <td style="vertical-align: top;">INPUT VOLTAGE CODE</td> <td style="vertical-align: top;"> <ul style="list-style-type: none"> 0 = 120V 1 = 208V 2 = 240V 3 = 277V 4 = 480V 5 = 120/240V 6 = 240/480V 7 = 120/208/240/277V 8 = 120/277V 9 = 120/208/240/277V </td> <td style="vertical-align: top;"> <ul style="list-style-type: none"> A = 102/277/347V B = 347V C = 120/347V D = 120/240/347V E = 120/208/240V or 208/240V F = 277/480V, 277/347V, 277/347/480V or 347/480V H = 127/220V J = 220V or 220/240V Y = 100/200V </td> <td style="vertical-align: top;"> <ul style="list-style-type: none"> M = 100/200 N = 120/220-240 R = 220/240 </td> </tr> </table>						60 Hz Voltages	50 Hz Voltages	INPUT VOLTAGE CODE	<ul style="list-style-type: none"> 0 = 120V 1 = 208V 2 = 240V 3 = 277V 4 = 480V 5 = 120/240V 6 = 240/480V 7 = 120/208/240/277V 8 = 120/277V 9 = 120/208/240/277V 	<ul style="list-style-type: none"> A = 102/277/347V B = 347V C = 120/347V D = 120/240/347V E = 120/208/240V or 208/240V F = 277/480V, 277/347V, 277/347/480V or 347/480V H = 127/220V J = 220V or 220/240V Y = 100/200V 	<ul style="list-style-type: none"> M = 100/200 N = 120/220-240 R = 220/240
	60 Hz Voltages	50 Hz Voltages									
INPUT VOLTAGE CODE	<ul style="list-style-type: none"> 0 = 120V 1 = 208V 2 = 240V 3 = 277V 4 = 480V 5 = 120/240V 6 = 240/480V 7 = 120/208/240/277V 8 = 120/277V 9 = 120/208/240/277V 	<ul style="list-style-type: none"> A = 102/277/347V B = 347V C = 120/347V D = 120/240/347V E = 120/208/240V or 208/240V F = 277/480V, 277/347V, 277/347/480V or 347/480V H = 127/220V J = 220V or 220/240V Y = 100/200V 	<ul style="list-style-type: none"> M = 100/200 N = 120/220-240 R = 220/240 								
Lamp Type/Wattage/Ballast Circuit Code											
Ballast Type	<ul style="list-style-type: none"> 71A = Core and Coil Ballast 72C = F-Can Ballast 73B = Encapsulated Core and Coil Ballast 74P = Postline Ballast 77K = Val-U-Pak Replacement Ballast Kit 78E = Indoor Enclosed Ballast 79W = Outdoor Weatherproof Ballast 										



HID - CORE & COIL BALLASTS

METAL HALIDE

(60 Hz., MINIMUM STARTING TEMPERATURE -20°F OR -30°C)



Input Volts	Catalog† Number	Circuit Type	Watts Input	Max Input Current	Nom Open Circuit Voltage	Fuse Rating (Amps)	Wiring Dia	Dimensions			Non-PCB Capacitor (Page 158-159)				Total Weight (lbs)	Ignitor †† (Page 160-163)		U.L. Bench Top Rise Code 1029 (pg 115)		
								Fig	A	B	Mfd	Min Volt	Dry Film			Oil Filled			Part Number	Max Dist To Lamp (ft)
													Dia (in)	Ht (in)		Oval (in)	Ht (in)			
250 Watt Lamp, ANSI Code M138 (Pulse-Start)																				
277	71A5737-B 71A5737-001D	Linear Reactor HPF	272	1.5	277	4	H	10	1.3	3.2	14	300	1.50	2.90	—	—	6.5	Integral Ignitor	5	A
120/208/240/277	71A5793 71A5793-001D	Super CWA	288	2.5/1.4/1.3/1.1	265	8/5/5/3	M	2	1.3	3.0	18.5	300	1.75	3.75	—	—	9.0	LI533-H4	15	A/A/A/B
120/240/120T	71A5704 71A5724-T	Regulated Lag	298	2.8	305	8	N	3	2.5	4.2	16	480	—	—	1.75	3.90	16.0	LI534-H5	20	A
277/120T	71A5734-T			1.4		4														
347/120T	71A5734-T			1.2		3														
480/120T	71A5744-T			1.0		3														
				.7		2														
250 Watt Lamp, ANSI Code M80 (HQI Double Ended and Mogul Base)																				
120/277	71A5880	HX-HPF	290	5.5/2.3	240	6	K	2	2.6	4.3	20	280	1.75	3.75	—	—	14.0	LI522-H5	5	A/A

† Ordering information:

Replacement/retrofit ballast kits indicated by **bold type** with suffix **-001D**.

71A5737-001D kits also include welded angle bracket.

Refer to pages 117-120.

Original equipment ballasts - add proper suffix to catalog number:

- 500D includes core & coil with dry-film capacitor
- 510D includes core & coil with welded bracket and dry-film capacitor
- 500 includes core & coil with oil-filled capacitor
- 510 includes core & coil with welded bracket and oil-filled capacitor
- 600 core & coil only (no capacitor)
- 610 core & coil with welded bracket (no capacitor)

†† Each ballast requiring an ignitor is furnished standard with the **Short Range** ignitor model shown for use within fixtures. If a **Long Range** ignitor is required for remote mounting, specify on order. See pages 160-163 for additional information.

- For CWA and Regulated Lag circuits, figure is operating current. For HX circuits, figure is highest of starting, operating or open circuit currents.

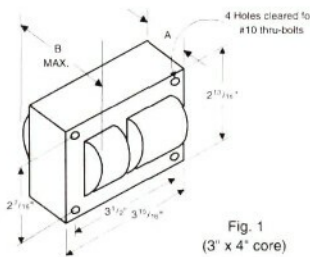

Fig. 1
(3' x 4' core)

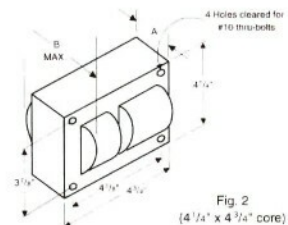

Fig. 2
(4 1/4' x 4 3/4' core)

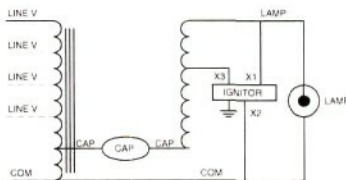

Fig. M

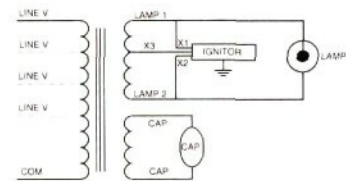

Fig. N

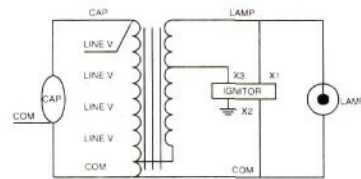

Fig. K

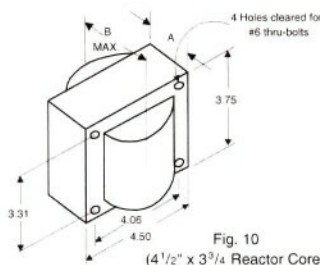

Fig. 10
(4 1/2' x 3 3/4' Reactor Core)

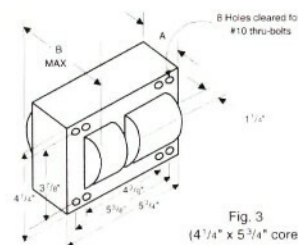
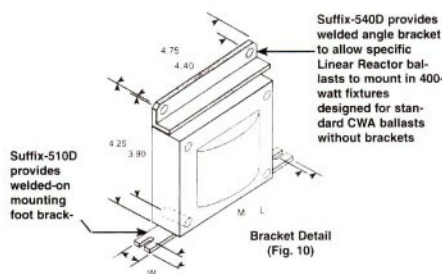
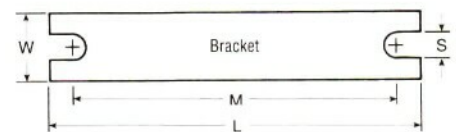

Fig. 3
(4 1/4' x 5 3/4' core)



Bracket Detail
(Fig. 10)



WELDED BRACKET DIMENSIONS

Ballast Dimensions Fig	L	W	M	S
1	5.1	1.00	4.50	0.25
2, 10	6.5	1.25	5.75	0.28
3	7.8	2.75	6.13	0.25

