

# ConTempo 150-250-350

RVP350 HPI-T400W IC 220V-50Hz A SP BK

MASTER HPI-T Plus - 400 W - Asymmetrical

The Contempo floodlight has a registered design that blends well with contemporary outdoor environments. It has a rugged pressure die-casted aluminum housing with corrosion resistant powder coating. Contempo also features an integrated energy saving copper ballast, electronic semi-parallel ignitor and capacitor. The unit has passed rigorous tests for dust and water ingress protection.

## Product data

General Information	
Number of light sources	1 pc
Lamp family code	HPI-TP [ MASTER HPI-T Plus]
Lamp power	400 W
Kombipack	-
Compensation circuit	Inductive parallel compensated
Gear	CONV [ Conventional]
Color	Black
Country version	NO [ Norway]
Optic type outdoor	Asymmetrical
Product family code	RVP350
Operating and Electrical	
Input Voltage	220 V
Input Frequency	50 Hz
Ignitor	Semi-parallel

Approval and Application	
Ingress protection code	IP65 [ Dust penetration-protected, jet-proof]
Product Data	
Full product code	910403342901
Order product name	RVP350 HPI-T400W IC 220V-50Hz A SP BK
EAN/UPC - Product	6923828686727
Order code	910403342901
Numerator - Quantity Per Pack	1
Numerator - Packs per outer box	1
Material Nr. (12NC)	910403342901
Net Weight (Piece)	10.700 kg



## ConTempo 150-250-350

### Dimensional drawing

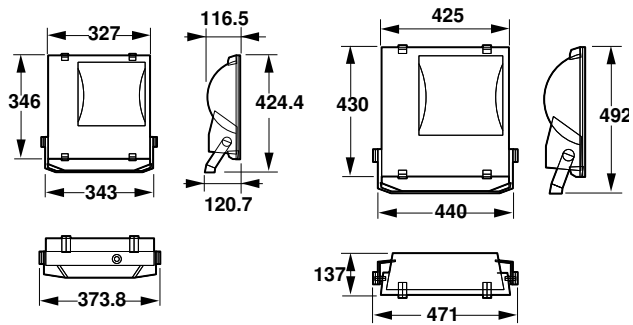

ConTempo RVP350

