



Project: \_\_\_\_\_  
 Location: \_\_\_\_\_  
 Cat.No: \_\_\_\_\_  
 Type: \_\_\_\_\_  
 Qty: \_\_\_\_\_  
 Notes: \_\_\_\_\_



EcoForm combines economy with performance in an LED area luminaire. Capable of delivering up to 20,000 lumens or more in a compact, low profile housing, EcoForm offers a new level of customer value. EcoForm features an innovative retrofit arm kit, simplifying site conversions to LED by eliminating the need to drill additional holes in most existing poles. Integral control systems, including motion response and wireless controls are available for further energy savings during off peak hours.

**Ordering guide**

example: ECF-APD-MRO-1-4-75LA-NW-120-NP-LF

Prefix	Controls	Mounting	Optics	LED Wattage	Color Temp	Voltage	Finish	Options
ECF -	-	-	-	-	-	-	-	
ECF EcoForm	<p>— Standard luminaire (leave blank)</p> <p><b>DIM</b> 0-10V Dimming</p> <p><b>APD</b><sup>1</sup> Auto Profile Dimming</p> <p><b>APD-MRO</b><sup>2</sup> Auto Profile Dimming and Motion Response Override pole mounted motion sensor</p> <p><b>APD-MRI</b><sup>2,3</sup> APD with Motion Response Override luminaire sensor</p> <p><b>MRI</b><sup>2,3</sup> Motion Response at 50% low luminaire sensor</p> <p><b>MR50</b><sup>2</sup> Motion Response at 50% low, pole mounted sensor</p> <p><b>LimeLight Wireless Controls</b></p> <p><b>LLC2</b><sup>1,5</sup> #2 lens for 8-15' mounted heights</p> <p><b>LLC3</b><sup>1,5</sup> #3 lens for 15-25' mounted heights</p> <p><b>LLC4</b><sup>1,5</sup> #4 lens for 25-40' mounted heights</p>	<p><b>1</b> Standard</p> <p><b>2</b> 2@180</p> <p><b>2@90</b> 2@90</p> <p><b>3</b> 3@90</p> <p><b>3@120</b> 3@120</p> <p><b>4</b> 4@90</p> <p><b>WS</b> Wall mount including surface conduit rear entry permitted</p> <p><b>MA</b> Mast Arm Fitter (requires 2-3/8" O.D. Mast Arm)</p>	<p><b>2</b> Type 2</p> <p><b>3</b> Type 3</p> <p><b>4</b> Type 4</p> <p><b>5</b> Type 5</p>	<p><b>530 mA</b></p> <p><b>55LA-3253</b><sup>1</sup></p> <p><b>75LA-4853</b></p> <p><b>100LA-6453</b></p> <p><b>700mA</b></p> <p><b>70LA-3270</b></p> <p><b>105LA-4870</b></p> <p><b>135LA-6470</b></p> <p><b>1050mA</b></p> <p><b>105LA-321A</b><sup>1</sup></p> <p><b>160LA-481A</b></p> <p><b>215LA-641A</b></p>	<p><b>CW</b> Cool White 5,700K 70 CRI (nominal)</p> <p><b>NW</b> Neutral White 4,000K 70 CRI (nominal)</p> <p><b>WW</b><sup>4</sup> Warm White 3,000K 70 CRI (nominal)</p>	<p><b>120</b> 120V</p> <p><b>208</b> 208V</p> <p><b>240</b> 240V</p> <p><b>277</b> 277V</p> <p><b>347</b> 347V</p> <p><b>480</b> 480V</p> <p><b>UNV</b> 120-277V 50hz/60hz</p> <p><b>HVU</b> 347-480V 50hz/60hz</p>	<p><b>BRP</b> Bronze Paint</p> <p><b>BLP</b> Black Paint</p> <p><b>WP</b> White Paint</p> <p><b>NP</b> Natural Paint</p> <p><b>OC</b> Optional Color Specify optional color or RAL (ex: OC-LGP or OC-RAL7024)</p> <p><b>SC</b> Special color Specify, must supply color chip. Requires factory quote.</p>	<p><b>TL</b> Tool-Less entry and driver removal hardware</p> <p><b>TB</b><sup>3</sup> Terminal Block</p> <p><b>IS</b><sup>6</sup> Internal Shield</p> <p><b>LF</b><sup>7</sup> Line Fusing</p> <p><b>LFC</b><sup>7</sup> Line Fusing for Canada</p> <p><b>PC</b><sup>5,7,8</sup> Receptacle with Photocell (Includes PCR5)</p> <p><b>PCB</b><sup>5,7,8</sup> Photocell Button</p> <p><b>PCRS</b><sup>5,11,13</sup> Photocell Receptacle only with 2 dimming connections</p> <p><b>PCR7</b><sup>5,12,13</sup> Photocell Receptacle only with 2 dimming and 2 auxiliary connections</p> <p><b>RAM</b> Retrofit Arm Mount kit</p> <p><b>PTF3</b><sup>9</sup> Pole Top Fitter for 2 3/8"- 3" Tenon</p> <p><b>PTF3</b><sup>9</sup> Pole Top Fitter for 3"- 3 1/2" Tenon</p> <p><b>PTF4</b><sup>9</sup> Pole Top Fitter for 3 1/2"- 4" Tenon</p> <p><b>RPA</b><sup>10</sup> Round Pole Adapter for 3"- 3.9" O.D.</p> <p><b>BD</b> Bird Deterrent (field installed only)</p>

- Available in 120V-277V Voltages only (UNV, 120, 208, 240 & 277).
- MR50 and APD-MRO luminaires require one motion sensor per pole, ordered separately. See page 2 for Accessories. Available in 120V or 277V only.
- ECF-MRI requires outboarded sensor when used with Terminal Block (TB) Option.
- Contact factory for lead times on warm white.
- LLC2/LLC3/LLC4 Wireless Controls are not configurable with PC/PCB/PCRS/PCR7 Options. See page 7-8 for more info.
- Not configurable with Type 5 (5) Optics.
- Not configurable with 120-277V (UNV) Voltage. Voltage must be specified.
- Not configurable with 480V (480) Voltage.
- Not configurable with 3@120 (3@120) Mounting.
- No adaptor required for 4" round poles. RPAs provided with Black Paint standard.
- Works with 3-pin or 5-pin NEMA photocell/dimming device.
- Works with 3-pin or 5-pin NEMA photocell/dimming device and auxiliary connections are not connected (for future use only).
- If ordered with DIM, APD, MRI, MR50, APD-MRI, APD-MRO, dimming will not be connected to NEMA receptacle.

# ECF EcoForm

## Site & Area

### EcoForm Accessories (order separately)

#### FS1R-100

MR hand held programmer

For use with 'MRI' motion response when field programming is required. If desired, only one is needed per job.

#### MS-A-120V

120V Input Area Motion Sensor  
For MR50 (Motion Response) or APD-MRO (Automatic Profile Dimming with Motion Response Override)

#### MS-A-277V

277V Input Area Motion Sensor  
For MR50 (Motion Response) or APD-MRO (Automatic Profile Dimming with Motion Response Override)

**Note:** Motion Sensors are ordered separately, with one (1) motion sensor required per pole location for MR50 or APD-MRO luminaires. See Luminaire Configuration Information on page 5 for more details. Area motion sensor color is Arctic White. MRI and APD-MRI luminaires include an integral motion sensor.

### EcoForm Drill Template (standard arm mount)

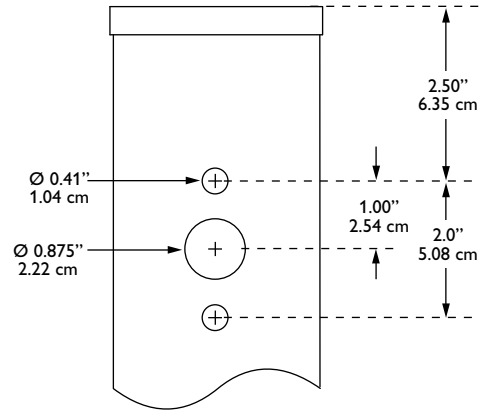

### LED Wattage and Lumen Values (standard EcoForm luminaire)

Order Code (standard units)	Array Quantity	Total LEDs	LED Current (mA)	Average System Watts <sup>1</sup>	LED Selection	Initial Lumens <sup>2</sup>			
						2 Type 2	3 Type 3	4 Type 4	5 Type 5
55LA-3253	2	32	530	52	NW	5,994 (s)	5,895 (s)	5,823 (s)	5,588 (s)
75LA-4853	3	48	530	77	NW	8,899 (s)	8,753 (s)	8,646 (s)	8,297 (s)
100LA-6453	4	64	530	103	NW	11,896 (s)	11,700	11,558	11,091
70LA-3270	2	32	700	69	NW	7,385 (s)	7,576 (s)	7,293 (s)	7,068 (s)
105LA-4870	3	48	700	104	NW	10,965 (s)	11,249 (s)	10,828 (s)	10,494 (s)
135LA-6470	4	64	700	139	NW	14,657 (s)	15,037	14,475 (s)	14,028
105LA-321A	2	32	1050	107	NW	10,199 (s)	10,458	10,072 (s)	9,767
160LA-481A	3	48	1050	158	NW	15,144 (s)	15,565	14,955 (s)	14,465
215LA-641A	4	64	1050	211	NW	20,243	20,252	19,991	19,880

1. System input wattage may vary based on input voltage, by up to +/- 10% , and based on manufacturer forward voltage, by up to +/- 8%.
2. Lumen values based on photometric tests performed in compliance with IESNA LM-79.  
(s). Data is scaled based on tests of similar, but not identical, luminaires.

### Dimensions – Standard EcoForm luminaire

Top View

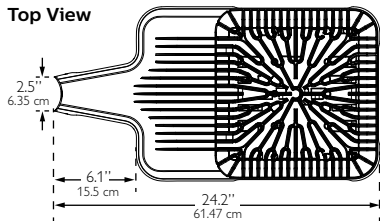

Side View

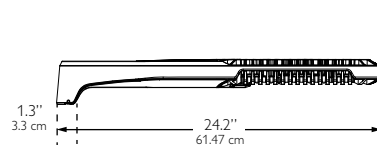

End View

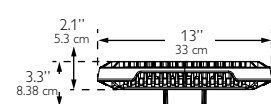

#### EPA (ft<sup>2</sup>/m<sup>2</sup>)

Single	Twin (2@180)	3/4@90
0.2 / 0.019	0.5 / 0.046	0.5 / 0.046

Approximate Luminaire Weight:  
20 Lbs (9.07 Kg)

# ECF EcoForm

## Site & Area

### Dimensions – EcoForm with Retrofit Arm Mount (RAM)

Top View

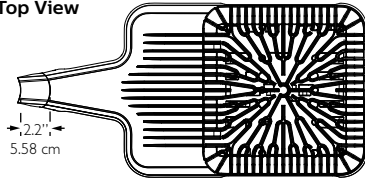

Side View

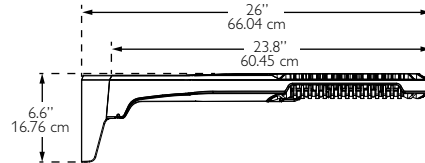

End View

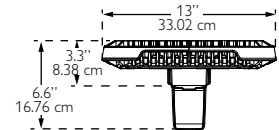

EPA (ft<sup>2</sup>/m<sup>2</sup>)

Single	Twin (2@180)	3/4@90
0.3 / 0.028	0.6 / 0.056	0.7 / 0.065

Approximate Luminaire Weight:  
21 Lbs (9.53 Kg)

### Dimensions – EcoForm with Mast Arm Fitter (MA)

Top View

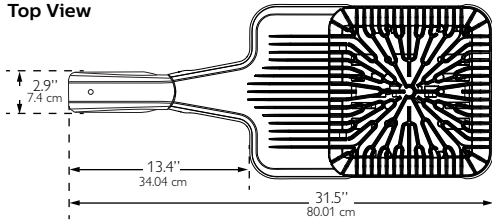

Side View

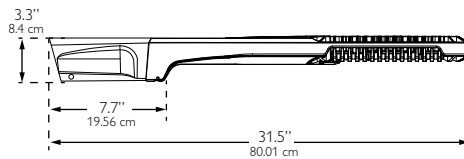

End View

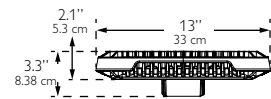

EPA (ft<sup>2</sup>/m<sup>2</sup>)

Single
0.51 / 0.047

Approximate Luminaire Weight:  
21.5 Lbs (9.77 Kg)

### Dimensions – EcoForm with Wall Mount (WS)

Top View

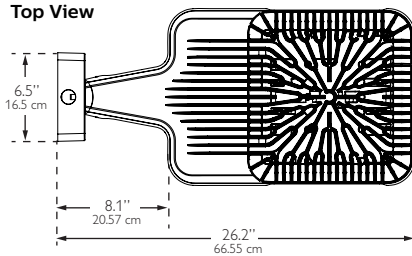

Side View

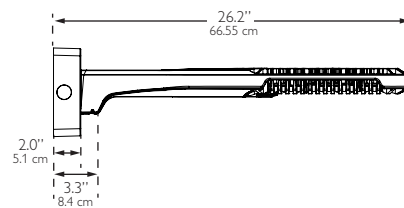

End View

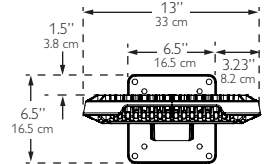

Approximate Luminaire Weight:  
23.36 Lbs (10.6 Kg)

### Dimensions – EcoForm with LimeLight Luminaire mounted controller

Top View

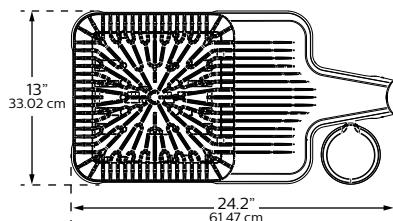

Side View

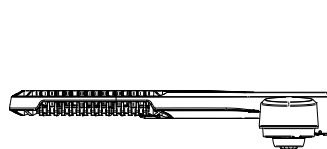

End View

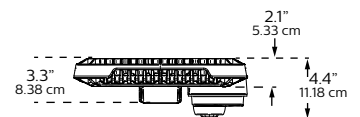

# ECF EcoForm

## Site & Area

### Luminaire Configuration Information

#### ECF

Philips Gardco EcoForm LED standard luminaire providing constant wattage and constant light output when power to the luminaire is energized.

#### ECF-DIM

Philips Gardco EcoForm LED luminaire provided with 0-10V dimming for connection to a control system provided by others.

#### ECF-APD

Philips Gardco EcoForm LED luminaire with Automatic Profile Dimming. Luminaire is provided with a Philips DynaDimmer module, programmed to go to 50% power, 50% light output two (2) hours prior to night time mid-point and remain at 50% for six (6) hours after night time mid-point. Mid-point is continuously recalculated by the Philips DynaDimmer module based on the average mid-point of the last two full night cycles. Short duration cycles, and power interruptions are ignored and do not affect the determination of mid-point.

ECF-APD is available in 120V–277V input only.

ECF-APD Dimming Profile:

100%	2 hours 50%	6 hours 50%	100%
Power On	Mid Point	Power Off	

#### ECF-MR50

Philips Gardco EcoForm LED luminaire with motion response, providing a 50% power reduction on low and a commensurate reduction in light output. The power and light output reduction is accomplished utilizing the Philips DynaDimmer module, programmed for a constant 50% power. Power supplied by the motion sensor connected to the override line on the DynaDimmer takes the luminaire to high setting, 100% power and light output, when motion is detected. The luminaire remains on high until no motion is detected for the motion sensor duration period, after which the luminaire returns to low. Duration period is factory set at 15 minutes, and is field adjustable from 5 minutes up to 15 minutes.

ECF-MR50 is available in 120V–277V input only to the luminaire. Motion sensors require single voltage 120V or 277V input.

The Area PIR motion sensor is the WattStopper EW-200-120-W (120V Input – MSA-120V) or the WattStopper EW-200-277-W (277V Input – MSA-277V.) One motion sensor per pole is required and is ordered separately. Area sensors require single voltage 120V or 277V input.

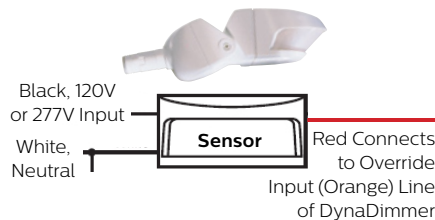

The area motion detector provides coverage equal to up to 6 times the sensor height above ground, 270° from the front-center of the sensor.

#### Area PIR Motion Sensor Coverage Pattern:

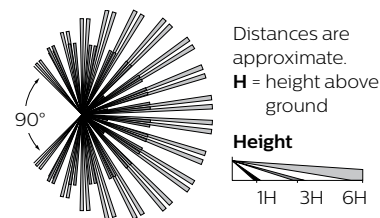

Motion response requires that the pole include an additional hand hole 15 feet above the pole base, normally oriented 180° to the standard hand hole. For Philips Gardco poles, order the pole with the Motion Sensor Mounting (MSM) option which includes the hand hole and a special hand hole cover plate for the sensor with a 1/2" NPT receptacle centered on the hand hole cover plate into which the motion sensor mounts. Once the motion sensor is connected to the hand hole cover plate, then wiring connections are completed in the pole. The plate (complete with motion sensor attached and wired) is then mounted to the hand hole. If poles are supplied by others, the customer is responsible for providing suitable mounting accommodations for the motion sensor in the pole.

#### Mounting to a Philips Gardco Pole:

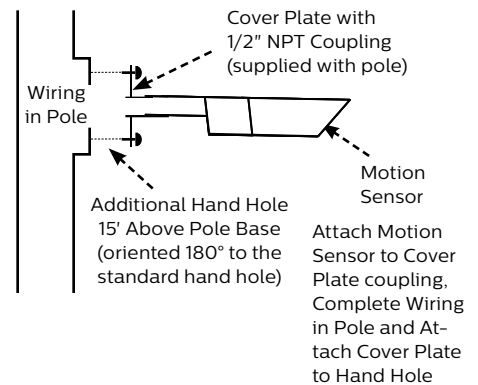

#### ECF-APD-MRO

Philips Gardco EcoForm LED luminaire with Automatic Profile Dimming, with Motion Response Override. The ECF-APD-MRO combines the benefits of both automatic profile dimming and motion response, using the Philips DynaDimmer module. The luminaire will dim to 50% power, 50% light output, per the dimming profile shown for the ECF-APD. If motion is detected during the time that the luminaire is operating at 50%, the luminaire returns to 100% power and light output. The luminaire remains on high until no motion is detected for the duration period, after which the luminaire returns to low. Duration period is factory set at 15 minutes, and is field adjustable from 5 minutes up to 15 minutes.

#### Notes:

ECF-APD-MRO is available in 120V through 277V input only to luminaire. The motion sensor requires either 120V or 277V input to the motion sensor.

The ECF-APD-MRO has the same pole requirements and utilizes the same motion sensors as the ECF-MR50. The motion sensor mounts and wires identically as well. The ECF-APD-MRO utilizes the identical dimming profile as shown for the ECF-APD.

By combining the benefits of automatic profile dimming and motion response, the ECF-APD-MRO assures maximum energy savings, and insures that adequate light is present if motion is detected.

All motion sensors utilized consume 0.0 watts in the off state.

# ECF EcoForm

## Site & Area

### Luminaire Configuration Information (Continued)

#### ECF-MRI

Luminaires with Motion Response include a LED driver and an integral programmable motion sensor. The motion sensor is set to a constant 50%. When motion is detected, the luminaire goes to 100%. The luminaire remains on high until no motion is detected for the motion sensor duration period, after which the luminaire returns to low. Duration period is factory set at 5 minutes. Available with 120V or 277V only.

Luminaires include a passive infrared (PIR) motion sensor, WattStopper® FSP-211 equipped with an FSP-L3 lens, capable of detecting motion within 20 feet of the sensor, 180° around the luminaire, when placed at a 20 foot mounting height, or mounted on a wall. Available in 120V or 277V input only. Motion sensor off state power is 0.0 watts.

The approximate motion sensor coverage pattern is as shown below.

#### Side Coverage Pattern

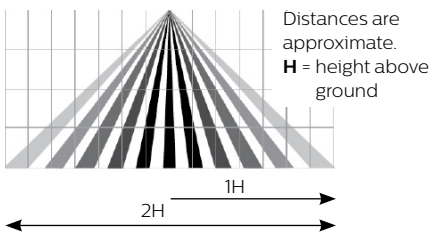

#### Top Coverage Pattern

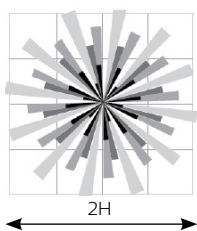

#### ECF-APD-MRI



Luminaires with Automatic Profile Dimming and Motion Response Override combine the benefits of both automatic profile dimming and motion response. APD-MRI luminaires utilize Philips DynaDimmer. The luminaire will dim to 50% power, 50% light output, per the dimming profile shown for APD luminaires (see page 4). If motion is detected during the time that the luminaire is operating at 50%, the luminaire goes to 100% power and light output. The luminaire remains on high until no motion is detected for the duration period, after which the luminaire returns to low. Duration period is factory set at 5 minutes.

APD-MRI luminaires are available with 120V or 277V input voltages only.

APD-MRI luminaires use the identical motion sensor as MRI luminaires. See motion sensor details for ECF-MRI.

#### FS1R-100 Wireless Remote Programming Tool

The FS1R-100 Remote Programming Tool accessory permits adjustment of ECF-MRI and ECF-APD-MRI sensor settings, including duration and dimming level on low, without the need to connect any wires to the luminaire.

The FS1R-100 Wireless IR Programming Tool is a handheld tool for setup and testing of WattStopper FSP-211. It provides wireless access to the FSP-211 sensors for setup and parameter changes.

The FS1R-100 display shows menus and prompts to lead you through each process. The navigation pad provides a familiar way to navigate through the customization fields.

Within a certain mounting height of the sensor, the FS1R-100 allows modification of the system without requiring ladders or tools simply with a touch of a few buttons.

The FS1R-100 IR transceiver allows bi-directional communication between the FSP-211 and the FS1R-100 programming tool. Simple menu screens let you see the current status of the system and make changes. It can change FSP-211 sensor parameters such as high/low mode, sensitivity, time delay, cut off and more. With the FS1R-100 you can also establish and store FSP-211 parameter profiles.

The FS1R-100 operates on three standard 1.5V AAA Alkaline batteries or three rechargeable AAA NiMH batteries. The battery status displays in the upper right corner of the display. Three bars next to BAT= indicates a full battery charge. A warning appears on the display when the battery level falls below a minimum acceptable level. To conserve battery power, the FS1R-100 automatically shuts off 10 minutes after the last key press.

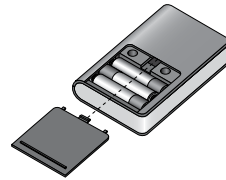

You navigate from one field to another using (up) or (down) arrow keys. The active field is indicated by flashing (alternates between yellow text on black background and black text on yellow background.)

Once active, use the Select button to move to a menu or function within the active field. Value fields are used to adjust parameter settings. They are shown in "less-than/greater-than" symbols: <value>. Once active, change them using (left) and (right) arrow keys. In general the up key increments and the down key decrements a value. Selections wrap-around if you continue to press the key beyond maximum or minimum values. Moving away from the value field overwrites the original value. The Home button takes you to the main menu. The Back button can be thought of as an undo function. It takes you back one screen. Changes that were in process prior to pressing the key are lost. More information on the FS1R-100 Remote Programming Tool is available at [wattstopper.com](http://wattstopper.com).

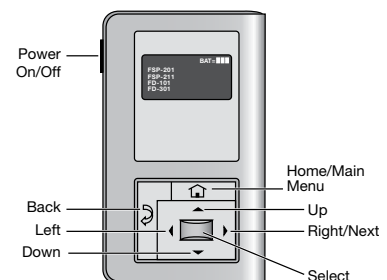

# ECF EcoForm

## Site & Area

### Luminaire Configuration Information – EcoForm with LimeLight

#### ECF-LLC2

EcoForm with Limelight wireless technology  
Controller pod attached to luminaire arm and includes radio, photocell and motion sensor with #2 lens for 8-15' mounting heights.

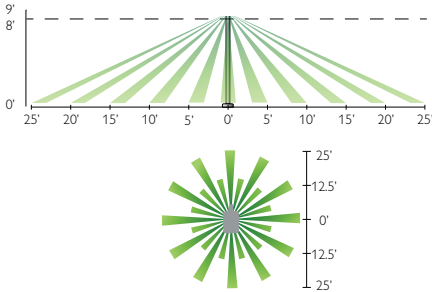

#### ECF-LLC3

EcoForm with Limelight wireless technology  
Controller pod attached to luminaire arm and includes radio, photocell and motion sensor with #3 lens for 15-25' mounting heights.

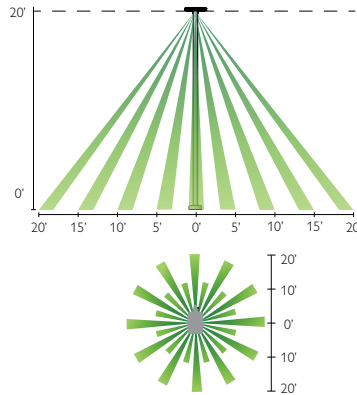

#### ECF-LLC4

EcoForm with Limelight wireless technology  
Controller pod attached to luminaire arm and includes radio, photocell and motion sensor with #4 lens for 25-40' mounting heights.

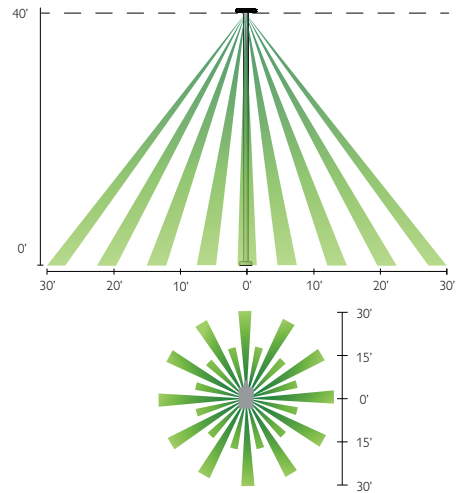

### Luminaire Configuration Information – EcoForm with LimeLight

#### ECF-LLC(#)

With this configuration, the controller pod is mounted to the luminaire arm. One controller is required per luminaire. There are three different motion sensor configurations available. Each one corresponds to the desired mounting height that for your specific application. See motion response detection ranges below.

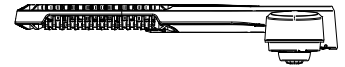
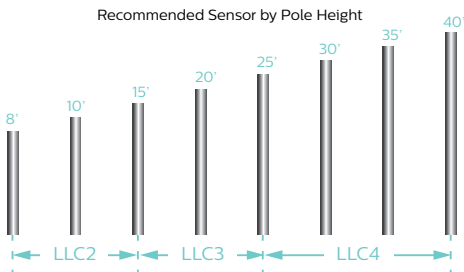

#### Controller Pod

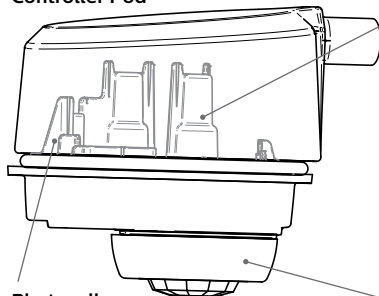

#### Wireless Radio

- 1.8 Watts max (no load draw)
- Operating voltage 102-277V RMS
- Communicates using the ZigBee protocol
- Carries out dimming commands from gateway
- Reports internal PCB temperature
- Transmission Systems Operating within the band 2400-2483.5Mhz. IEEE 802.15.4
- ROHS Compliant

#### Photocell

- Ambient light photocell on every wireless radio that averages the light levels of up to 5 controllers for an accurate reading and optimal light harvesting activity.
- Reports ambient light readings to 1500 Fc.

#### Motion Response

- Three different lens configurations
- Detects motion through passive InfraRed sensing technology
- Connects directly to radio through modular jack
- Three different mounting heights and detection ranges available

# ECF EcoForm

## Site & Area

### Luminaire Configuration Information – EcoForm with LimeLight (Continued)

#### Gateway

**Overview:** One gateway is included with the wireless controls system. The gateway opens up communication with the wireless radios installed with the EcoForm luminaires (or pole), allowing you to control your fixtures straight from the web. One LimeLight gateway can communicate with up to 800 fixtures. Typically one unit is required per parking lot.

**Installation:** Gateway has 4 blind threaded holes on the back side that accept 10-32 screws. Mount spacing is 10.41" across and 14.19" vertical.

**Requirements:** The gateway must be mounted in a secure on-site location. The gateway requires 120V. Distance of gateway to the first radio varies upon application; contact factory. Strong internet connection required.

#### Specifications:

- High density RF Mesh coordinator
- Ethernet or wireless internet connection to LimeLight server
- Proprietor of software "rules of operation"
- Watertight Ethernet connections
- Highly protected, long life ac/dc power supply
- Single board, ARM compliant 520Mhz Intel computer.
- Operating Temperature -20°C to 55°C
- Tamper proof housing

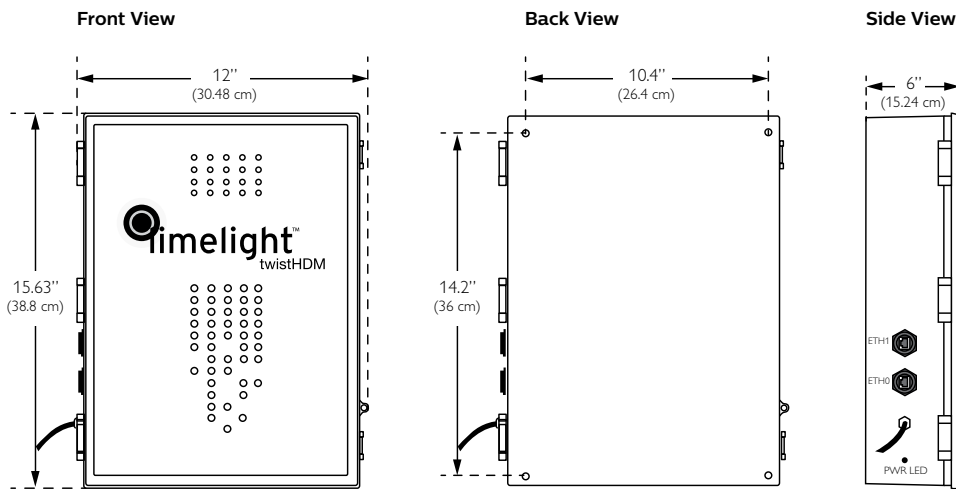
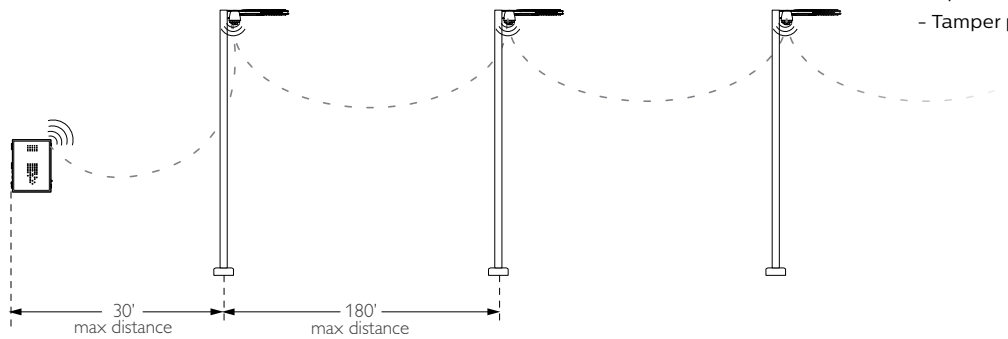

### Specifications

#### Housing

One piece die cast aluminum housing with integral arm and separate, self retained hinged, one piece die cast door frame.

#### IP Rating

LED light engine rated IP66.

#### Vibration Resistance

EcoForm with Standard Arm carries a 3G vibration rating that conforms to standards set forth by ANSI C136.31. Testing includes vibration to 3G acceleration in three axes, all performed on the same luminaire.

#### Electrical

Driver efficiency (>90% standard). 120-480V available (restrictions apply). Open/short circuit protection. Optional 0-10V dimming to 10% power. RoHS compliant. Surge protector standard. 10KA per ANSI/IEEE C62.41.2.

#### LED Board and Array

32, 48, or 64 LEDs. Color temperatures: 3000K, 4000K, 5700K +/- 250K. Minimum CRI of 70. Aluminum metal clad board. RoHS compliant.

#### LED Thermal Management

The housing design allows the one piece housing to provide excellent thermal management critical to long LED system life.

#### Energy Saving Benefits

System efficacy up to 95 lms/W with significant energy savings over Pulse Start Metal Halide luminaires. Optional control options provide added energy savings during unoccupied periods.

#### LED Performance

Predicted Lumen Depreciation Data<sup>1</sup>

Ambient Temperature °C	Driver (mA)	Calculated L <sub>70</sub> Hours <sup>1,2</sup>	L <sub>70</sub> Per TM-21 <sup>2,3</sup>	Lumen Maintenance % @ 60,000 hours
Up to 40 °C	Up to 1050 mA	> 350,000 hours	> 60,000 hours	97%

1. Predicted performance derived from LED manufacturer's data and engineering design estimates, based on IESNA LM-80 methodology. Actual experience may vary due to field application conditions.
2. L70 is the predicted time when LED performance depreciates to 70% of initial lumen output.
3. Calculated per IESNA TM21-11. Published L70 hours limited to 6 times actual LED test hours.

#### Wireless Controls

The LimeLight wireless Controls System includes: gateway, controller pod (with wireless radio, motion response, and photocell), and commissioning/training. LimeLight is an intelligent web-based system that operates through a high density mesh (HDM) wireless technology. Wireless radios with motion response and photocell sensors are integrated with PureForm luminaires, and enable the fixtures to communicate via the ZigBee protocol. The gateway is a mini computer that connects to the internet, and is located in a secure location. The central LimeLight database channels communication to and from the gateway, allowing data to be viewed or managed through the web-based graphical user interface (GUI). See LimeLight pages for details and technical information.

#### Motion Sensors

ECF-MR50, ECF-APD-MRO, ECF-MRI, ECF-APD-MRI luminaires may be specified for additional energy savings during unoccupied periods. See pages 4-6 for complete details.

#### Optical Systems

Type 2, 3, 4, and 5 distributions available. Internal Shield option mounts to LED optics and is available with Type 2, 3, and 4 distributions to control backlight.

#### Mounting

Standard luminaire arm mounts to 4" round poles. Square pole adapter included with every luminaire. Round Pole Adapter (RPA) required for 3-3.9" poles.

#### Retrofit Arm Mount

EcoForm features an innovative retrofit arm kit. When specified with the retrofit arm (RAM) option, EcoForm seamlessly simplifies site conversions to LED by eliminating the need for additional pole drilling on most existing poles. RAM will be boxed separately.

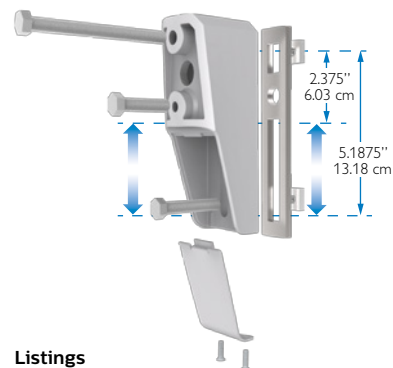

#### Listings

ETL/cETL listed to the UL 1598 standard, suitable for Wet Locations. Suitable for use in ambients from -40° to 40°C (-40° to 104°F). The quality systems of this facility have been registered by UL to the ISO 9001 series standards. All EcoForm luminaires equipped with NW and CW are DesignLights Consortium® qualified.

#### Finish

Each standard color luminaire receives a fade and abrasion resistant, electrostatically applied, thermally cured, triglycidyl isocyanurate (TGIC) textured polyester powdercoat finish. Standard colors include bronze (BRP), black (BLP), white (WP), and natural aluminum (NP). Consult factory for specs on optional or custom colors.

#### Warranty

EcoForm luminaires feature a 5 year limited warranty. Philips Gardco LED luminaires with LED arrays feature a 5 year limited warranty covering the LED arrays. LED Drivers also carry a 5 year limited warranty. Motion sensors are covered by warranty for 5 years by the motion sensor manufacturer.

