

# PHILIPS Day-Brite CFI

Industrial

APX LED high bay

8000, 12000, 16000, 20000  
or 24000 lumens



Project: \_\_\_\_\_  
 Location: \_\_\_\_\_  
 Cat.No: \_\_\_\_\_  
 Type: \_\_\_\_\_  
 Lamps: \_\_\_\_\_ Qty: \_\_\_\_\_  
 Notes: \_\_\_\_\_

The Philips Day-Brite / Philips CFI APX LED linear high bay provides versatility in form and function. With a range of lumen packages, optical distributions, and accessories available, this luminaire can be used in many different applications ranging from warehouses to food processing.

## Ordering guide

Example: APX24LL40-UNV

Family	Lumens	Lamp Source	CCT	Voltage	Optics	Options
APX		L	–	–	–	
APX	<b>08L</b> 8000 nominal delivered lumens <b>12L</b> 12000 nominal delivered lumens <b>16L</b> 16000 nominal delivered lumens <b>20L</b> 20000 nominal delivered lumens <b>24L</b> 24000 nominal delivered lumens	L LED	<b>35</b> 3500K (CRI 80) <b>40</b> 4000K (CRI 80) <b>50</b> 5000K (CRI 80)	<b>UNV</b> Universal voltage, 120-277V <b>120</b> 120V <b>208</b> 208V <b>240</b> 240V <b>277</b> 277V <b>347</b> 347V <b>480</b> 480V	<b>Blank</b> General Distribution <b>N</b> Narrow <b>M</b> Medium <b>W</b> Wide <b>A</b> Aisle	<b>WP6<sup>56</sup></b> Wired 6' 16/3 cord & MENCORM plug and receptacle <b>WC6</b> Wired 6' 16/3 cord <b>WP6D<sup>56</sup></b> Wired 6' 16/3 cord & MENCORM plug and receptacle for line voltage and wired MENCORM plug and receptacle for dimming control <b>WC6D</b> Wired 6' 16/3 cord for line voltage and wired 6' cord for dimming control <b>MD360W</b> 360° Motion detector (ON/OFF) (not available for 208V or 240V) <b>EMLED</b> Emergency battery (30°C max) <b>LFA</b> Frosted acrylic lens <b>LCP</b> Clear polycarbonate lens <b>LFP</b> Frosted polycarbonate lens <b>TP</b> Tamperproof screws <b>C</b> Ceiling mount hangers <b>GLR</b> Fusing, fast blow <b>SP1</b> Optional 10kV surge protector

## Footnotes

56 Must specify line voltage

## Wiring Notes

Standard cords have 3 wires. Consult factory for other cord options.

## General Notes

- All options factory installed.
- All accessories are field installed.
- Many luminaire components, such as reflectors, refractors, lenses, sockets, lampholders, and LEDs are made from various types of plastics which can be adversely affected by airborne contaminants. If sulfur based chemicals, petroleum based products, cleaning solutions, or other contaminants are expected in the intended area of use, consult factory for compatibility.

## Predicted L<sub>70</sub> Lifetime

Max. Ambient > 100,000 hours

(based upon LED manufacturer's supplied LM-80 data and in-situ laboratory testing)



# APX LED linear high bay

8000, 12000, 16000, 20000, or 24000 lumens

## Application

- Sealed, corrosion resistant luminaire for use in food processing or other industrial applications.

## Construction/Finish

- White, one-piece, molded fiberglass reinforced polyester housing with formed in place gasket.
- Injection molded, high impact clear acrylic lens is standard. Frosted acrylic, clear UV stabilized polycarbonate, or frosted UV stabilized polycarbonate lenses are optional.
- Tamper-resistant, stainless steel, captive latches provide durability. Optional tamper resistant screws are available.
- Plugs installed in ends of luminaire for field installation of 1/2" conduit or Romex connector (by others).
- Hinged board tray and lens tethers for easy installation and maintenance.

- Two stainless steel V-cable hangers are included for chain or cable mounting. Optional ceiling mount brackets available.
- LED light engines and drivers are field replaceable.
- Dimming drivers are standard. Control is 0-10V.
- 5 Year Limited Warranty.
- Standard NSF listing for Non-Food Zone and Splash Zone.
- Housing is IP65/IP67/NEMA 4X rated.
- ETL listed to meet UL 1598 standards for wet location.
- Designlights Consortium® qualified. Please check the DLC Qualified Products List to confirm ([www.designlights.org/QPL](http://www.designlights.org/QPL)).

Luminaire	Ambient
24,000 lumen	-35°C to 35°C
All others	-35°C to 40°C
EMLED option	0°C to 30°C

## Dimensions

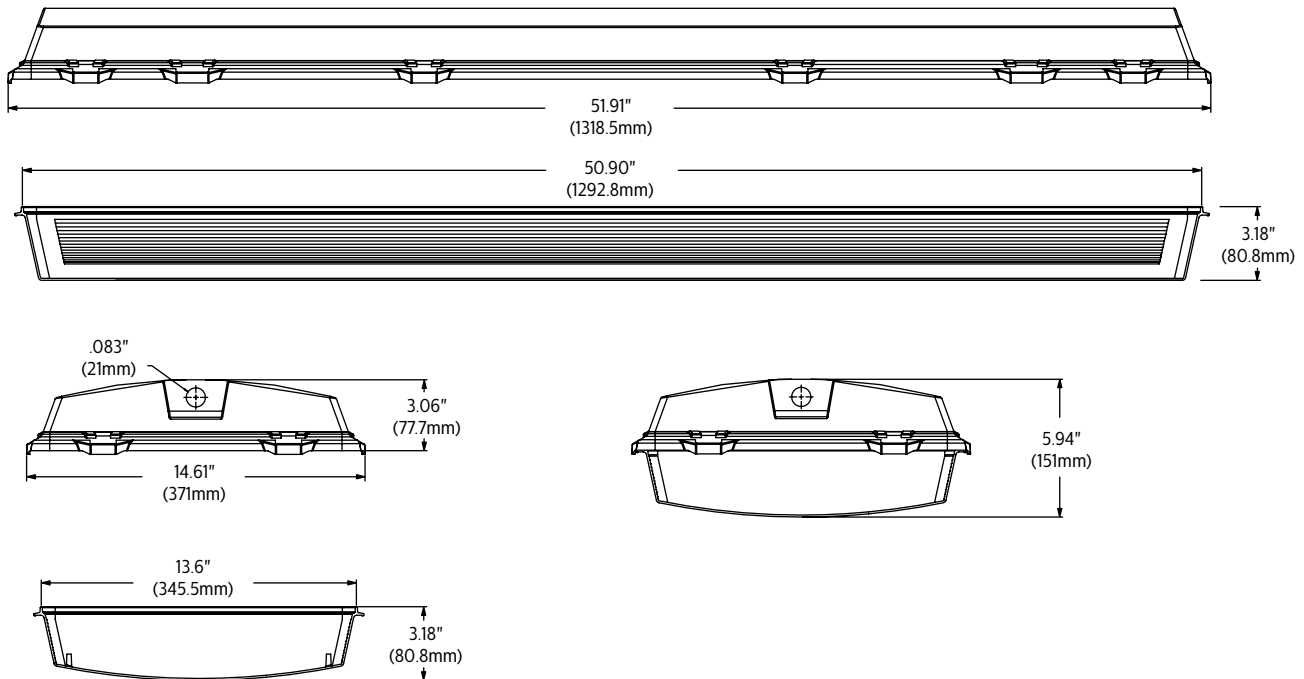

# APX LED linear high bay

8000, 12000, 16000, 20000, or 24000 lumens

## Photometry

### APX LED high bay, general distribution, 24,000 nominal delivered lumens

<b>Catalog No.</b>	APX24LL40-UNV	<b>Candlepower</b>				<b>Light Distribution</b>			<b>Average Luminance</b>			
<b>Test No.</b>	33644	<b>Angle</b>	<b>End</b>	<b>45</b>	<b>Cross</b>	<b>Degrees</b>	<b>Lumens</b>	<b>% Luminaire</b>	<b>Angle</b>	<b>End</b>	<b>45°</b>	<b>Cross</b>
<b>S/MH</b>	1.3	0	7753	7753	7753	0-30	6148	26.2	45	15721	14483	14419
<b>Lamp Type</b>	LED	5	7699	7749	7748	0-40	10168	43.2	55	14763	13621	9527
<b>Lumens</b>	23,441	15	7485	7571	7579	0-60	18097	77.2	65	12827	7525	10297
<b>Input Watts</b>	191	25	7049	7131	7129	0-90	22999	98.1	75	9123	10127	7485
<b>Efficacy</b>	123	35	6379	6438	6425	90-180	442	1.9	85	4559	5795	7036
		45	5438	5547	5608	0-180	23441	100.0				
		55	4225	4483	3201							
		65	2793	1997	2810							
		75	1302	1959	1508							
		85	289	670	873							
		95	100	113	136							
		105	130	82	95							
		115	68	70	79							
		125	36	81	59							
		135	18	36	52							
		145	9	12	28							
		155	5	6	10							
		165	5	5	5							
		175	5	5	5							
Comparative yearly lighting energy cost per 1000 lumens – <b>\$1.95</b> based on 3000 hrs. and 5.08 pwr KWH.												
The photometric results were obtained in the Phillips Day-Brite laboratory which is NVLAP accredited by the National Institute of Standards and Technology.												
Photometric values based on test performed in compliance with LM-79.												

### APX LED high bay, medium distribution, 24,000 nominal delivered lumens

<b>Catalog No.</b>	APX24LL40-UNV-M	<b>Candlepower</b>				<b>Light Distribution</b>			<b>Average Luminance</b>			
<b>Test No.</b>	33719	<b>Angle</b>	<b>End</b>	<b>45</b>	<b>Cross</b>	<b>Degrees</b>	<b>Lumens</b>	<b>% Luminaire</b>	<b>Angle</b>	<b>End</b>	<b>45°</b>	<b>Cross</b>
<b>S/MH</b>	1.4	0	12659	12659	12659	0-30	10835	47.3	45	10620	14710	11421
<b>Lamp Type</b>	LED	5	12663	12731	12789	0-40	17090	74.5	55	3646	3173	1974
<b>Lumens</b>	22,931	15	12969	13205	13216	0-60	21857	95.3	65	2815	1428	1610
<b>Input Watts</b>	191	25	11698	13144	13514	0-90	22750	99.2	75	1871	1320	1448
<b>Efficacy</b>	120	35	8784	10527	10683	90-180	181	0.8	85	1155	1398	2191
		45	3673	5634	4442	0-180	22931	100.0				
		55	1043	1044	663							
		65	613	379	439							
		75	267	255	292							
		85	73	162	272							
		95	26	56	119							
		105	30	37	48							
		115	15	29	42							
		125	8	24	32							
		135	7	18	28							
		145	4	6	17							
		155	3	3	7							
		165	4	4	4							
		175	4	4	4							
Comparative yearly lighting energy cost per 1000 lumens – <b>\$2.00</b> based on 3000 hrs. and 5.08 pwr KWH.												
The photometric results were obtained in the Phillips Day-Brite laboratory which is NVLAP accredited by the National Institute of Standards and Technology.												
Photometric values based on test performed in compliance with LM-79.												

# APX LED linear high bay

8000, 12000, 16000, 20000, or 24000 lumens

## Photometric Test List

Catalog No.	Test No.	Delivered Lumens	Input Watts	Efficacy
APX08LL40-UNV	33946	9823	76	129
APX08LL40-UNV-LFA	33945	8463	76	111
APX08LL40-UNV-LCP	33944	9439	76	124
APX08LL40-UNV-LFP	33943	9511	76	125
APX08LL40-UNV-N	33947	9696	75	129
APX08LL40-UNV-N-LFA	33948	8635	76	114
APX08LL40-UNV-N-LCP	33949	9411	75	125
APX08LL40-UNV-N-LFP	33950	9512	75	127
APX08LL40-UNV-M	33962	9543	76	126
APX08LL40-UNV-M-LFA	33961	8504	76	112
APX08LL40-UNV-M-LCP	33960	9242	76	122
APX08LL40-UNV-M-LFP	33959	9427	76	124
APX08LL40-UNV-W	33963	9614	76	127
APX08LL40-UNV-W-LFA	33964	8288	76	109
APX08LL40-UNV-W-LCP	33965	9206	76	121
APX08LL40-UNV-W-LFP	33966	9335	76	123
APX08LL40-UNV-A	33978	9661	76	127
APX08LL40-UNV-A-LFA	33977	8391	76	110
APX08LL40-UNV-A-LCP	33976	9278	76	122
APX08LL40-UNV-A-LFP	33975	9382	76	123
APX12LL40-UNV	33939	11987	96	125
APX12LL40-UNV-LFA	33940	10361	96	108
APX12LL40-UNV-LCP	33941	11541	96	120
APX12LL40-UNV-LFP	33942	11630	96	121
APX12LL40-UNV-N	33954	11817	96	123
APX12LL40-UNV-N-LFA	33953	10501	96	109
APX12LL40-UNV-N-LCP	33952	11424	96	119
APX12LL40-UNV-N-LFP	33951	11597	96	121
APX12LL40-UNV-M	33955	11753	96	122
APX12LL40-UNV-M-LFA	33956	10386	96	108
APX12LL40-UNV-M-LCP	33957	11342	96	118
APX12LL40-UNV-M-LFP	33958	11538	96	120
APX12LL40-UNV-W	33970	11711	96	122
APX12LL40-UNV-W-LFA	33969	10119	96	105
APX12LL40-UNV-W-LCP	33968	11262	96	117
APX12LL40-UNV-W-LFP	33967	11400	96	119
APX12LL40-UNV-A	33971	11804	96	123
APX12LL40-UNV-A-LFA	33972	10296	96	107
APX12LL40-UNV-A-LCP	33973	11333	96	118
APX12LL40-UNV-A-LFP	33974	11461	96	119
APX16LL40-UNV	33672	16171	123	131
APX16LL40-UNV-LFA	33675	13899	123	113
APX16LL40-UNV-LCP	33673	15531	123	126
APX16LL40-UNV-LFP	33674	15644	123	127
APX16LL40-UNV-N	33704	15933	124	128
APX16LL40-UNV-N-LFA	33705	14121	123	115
APX16LL40-UNV-N-LCP	33706	15487	123	126
APX16LL40-UNV-N-LFP	33707	15660	123	127
APX16LL40-UNV-M	33727	15869	123	129
APX16LL40-UNV-M-LFA	33726	13994	123	114

Catalog No.	Test No.	Delivered Lumens	Input Watts	Efficacy
APX16LL40-UNV-M-LCP	33725	15414	123	125
APX16LL40-UNV-M-LFP	33724	15565	123	127
APX16LL40-UNV-W	33728	15801	123	128
APX16LL40-UNV-W-LFA	33729	13624	123	111
APX16LL40-UNV-W-LCP	33730	15169	123	123
APX16LL40-UNV-W-LFP	33731	15343	123	125
APX16LL40-UNV-A	33751	15779	123	128
APX16LL40-UNV-A-LFA	33750	13608	123	111
APX16LL40-UNV-A-LCP	33749	15106	123	123
APX16LL40-UNV-A-LFP	33748	15548	123	126
APX20LL40-UNV	33651	21158	168	126
APX20LL40-UNV-LFA	33650	18262	168	109
APX20LL40-UNV-LCP	33649	20334	168	121
APX20LL40-UNV-LFP	33648	20528	168	122
APX20LL40-UNV-N	33711	20667	168	123
APX20LL40-UNV-N-LFA	33710	18450	168	110
APX20LL40-UNV-N-LCP	33709	20057	168	119
APX20LL40-UNV-N-LFP	33708	20338	168	121
APX20LL40-UNV-M	33720	20737	168	123
APX20LL40-UNV-M-LFA	33721	18334	168	109
APX20LL40-UNV-M-LCP	33722	20106	168	120
APX20LL40-UNV-M-LFP	33723	20307	168	121
APX20LL40-UNV-W	33735	20657	168	123
APX20LL40-UNV-W-LFA	33734	17797	168	106
APX20LL40-UNV-W-LCP	33733	19869	168	118
APX20LL40-UNV-W-LFP	33732	20040	168	119
APX20LL40-UNV-A	33744	20722	169	123
APX20LL40-UNV-A-LFA	33745	17803	168	106
APX20LL40-UNV-A-LCP	33746	20066	169	119
APX20LL40-UNV-A-LFP	33747	20271	169	120
APX24LL40-UNV	33644	23441	191	123
APX24LL40-UNV-LFA	33645	20117	190	106
APX24LL40-UNV-LCP	33646	22533	191	118
APX24LL40-UNV-LFP	33647	22667	191	119
APX24LL40-UNV-N	33712	22833	191	120
APX24LL40-UNV-N-LFA	33713	20381	191	107
APX24LL40-UNV-N-LCP	33714	22211	191	116
APX24LL40-UNV-N-LFP	33715	22401	191	117
APX24LL40-UNV-M	33719	22931	191	120
APX24LL40-UNV-M-LFA	33718	20213	191	106
APX24LL40-UNV-M-LCP	33717	22179	191	116
APX24LL40-UNV-M-LFP	33716	22467	191	118
APX24LL40-UNV-W	33736	22828	191	120
APX24LL40-UNV-W-LFA	33737	19626	191	103
APX24LL40-UNV-W-LCP	33738	22001	191	115
APX24LL40-UNV-W-LFP	33739	22190	191	116
APX24LL40-UNV-A	33743	23135	191	121
APX24LL40-UNV-A-LFA	33742	19686	191	103
APX24LL40-UNV-A-LCP	33741	21975	191	115
APX24LL40-UNV-A-LFP	33740	22291	191	117

© 2016 Philips Lighting Holding B.V. All rights reserved. Philips reserves the right to make changes in specifications and/or discontinue any product at any time without notice or obligation and will not be liable for any consequences resulting from the use of this publication. [philips.com/luminaires](http://philips.com/luminaires)



Philips Lighting North America Corporation  
200 Franklin Square Drive, Somerset, NJ 08873  
Tel. 855-486-2216

Philips Lighting Canada Ltd.  
281 Hillmount Rd, Markham, ON, Canada L6C 2S3  
Tel. 800-668-9008