

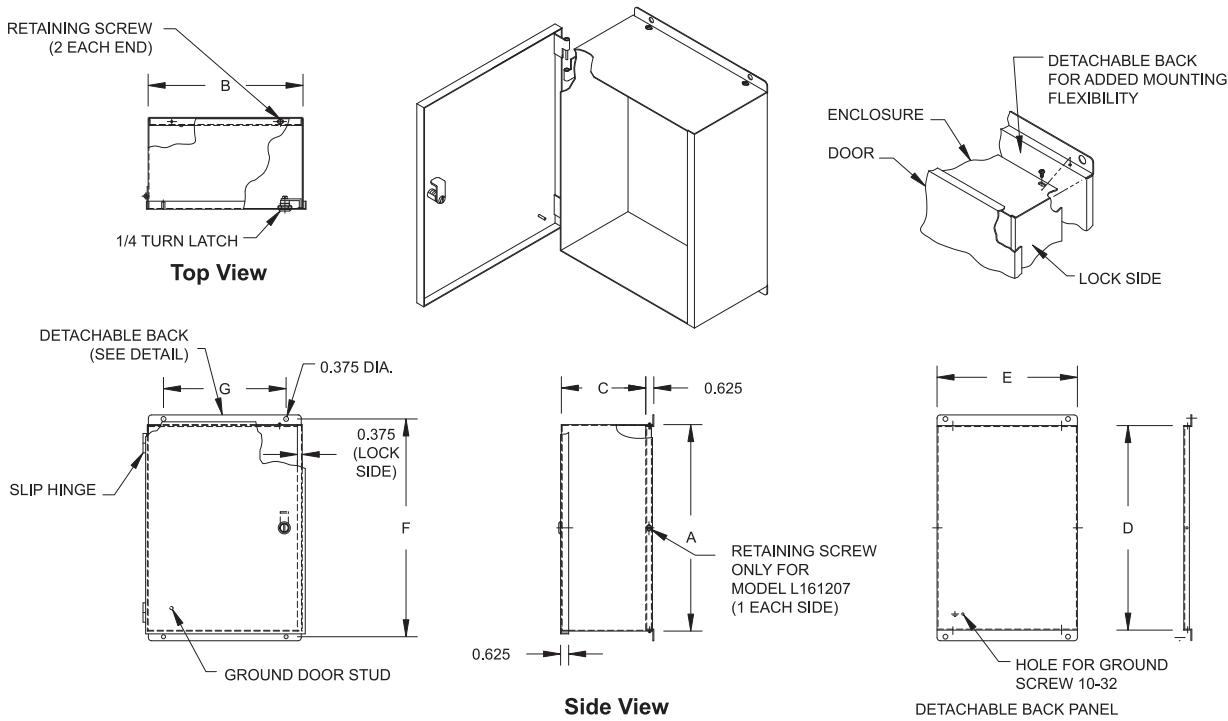

L Series

EEMAC / NEMA 1 Single Door Enclosures



Application:

Type 1 general purpose enclosure designed to house electrical, pneumatic or hydraulic instruments

Construction:

- 16 gauge steel frame and door
- 16 or 14 gauge steel detachable mounting back
- Slip hinges enabling door removal for easier access and mounting
- 1/4 turn latch
- Grounding stud on inner door side
- Grounding screw on detachable back
- ANSI/ASA61 grey polyester - epoxy textured powder coating inside out

Also Available:

- Aluminium, SS, galvanized steel
- Cutouts, hubs
- Special finishes & sizes

Standards:

- CSA certified 150359
- UL listed E109310

TECHNICAL READOUT

Catalog No.	Dimensions			Panel		Mounting Holes		Weight lbs
	A	B	C	D	E	F	G	
L080606	8	6	6	7.849 x	5.849	8.875	3.5	6
L100804	10	8	4	9.849 x	7.849	10.875	5.5	12
L100806	10	8	6	9.849 x	7.849	10.875	5.5	8.5
L121007	12	10	7	11.849 x	9.849	12.875	7.5	16
L151206	15	12	6	14.849 x	11.849	15.875	9.5	25
L161207	16	12	7	15.849 x	11.849	16.875	9.5	21





S Series

EEMAC / NEMA 4-4x-12 / IP-65 Hinged Lift-Off Cover Enclosures

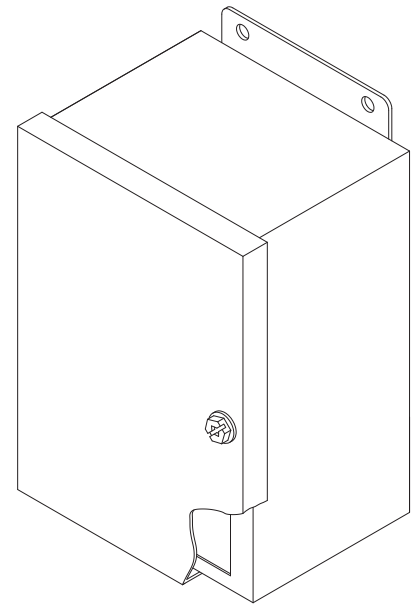
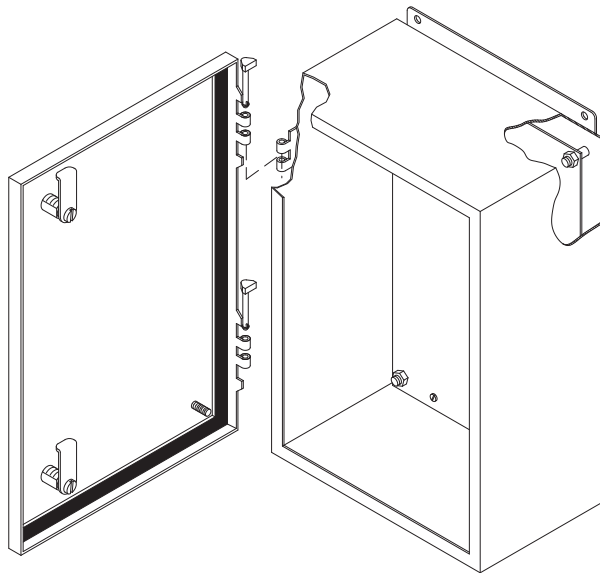

TECHNICAL READOUT

Catalog No.	Dimensions			Panel		Weight lbs
	A	B	C	E	F	
S040403*	4	4	3	no panel		2
S040404*	4	4	4	no panel		3.5
S060403*	6	4	3	4.875 x 2.875		3
S060404*	6	4	4	4.875 x 2.875		4
S060604	6	6	4	4.875 x 4.875		5
S080604	8	6	4	6.875 x 4.875		7
S080804	8	8	4	6.875 x 6.875		8
S100804	10	8	4	8.875 x 6.875		10
S121005	12	10	5	10.875 x 8.875		15
S100806	10	8	6	8.875 x 6.875		11
S101006	10	10	6	8.875 x 8.875		14
S121206	12	12	6	10.875 x 10.875		18
S141206	14	12	6	12.875 x 10.875		21
S161406	16	14	6	14.875 x 12.875		26
S121008	12	10	8	10.875 x 8.875		18
S141208	14	12	8	12.875 x 10.875		22
S161408	16	14	8	14.875 x 12.875		24
S161410	16	14	10	14.875 x 12.875		28

* CAPTIVE SCREW

Application:

Type 4-4x-12 / IP-65 enclosure designed for INDOOR/OUTDOOR housing of electrical, pneumatic or hydraulic instruments.

Construction:

- 16 gauge steel
- Slip hinges enabling cover removal for easier access and mounting
- Continuously welded and ground smooth seams
- 14 gauge galvanized steel panel natural finish (unpainted)
- 1/4 turn latch
- Grounding screw on mounting panel
- Grounding stud welded on inner cover surface
- ANSI/ASA61 grey polyester - epoxy textured powder coating inside out

Also Available:

- Aluminium, SS, galvanized steel
- Cutouts, louvers, additional knockouts
- Tamper proof screw
- Special finishes & sizes

Standards:

- CSA certified 150359
- UL listed E109310
- CE





S..AI / S..SS

EEMAC / NEMA 4-4x-12 / IP-65 Hinged Lift-Off Cover Enclosures

Hinged Lift-Off Aluminium Enclosures

TECHNICAL READOUT

Catalog No.	Dimensions			Panel		Weight lbs
	A	B	C	E	F	
S040403AL	4	4	3	no panel		1
S060403AL	6	4	3	4.875 x 2.875		1.5
S060604AL	6	6	4	4.875 x 4.875		2.5
S080604AL	8	6	4	6.875 x 4.875		3.5
S100804AL	10	8	4	8.875 x 6.875		4.5
S121005AL	12	10	5	10.875 x 8.875		7
S141206AL	14	12	6	12.875 x 10.875		10
S161406AL	16	14	6	14.875 x 12.875		13
S141208AL	14	12	8	12.875 x 10.875		12
S161410AL	16	14	10	14.875 x 12.875		15

Application:

Type 4-4x-12 / IP-65 aluminium enclosure designed for INDOOR/OUTDOOR housing of electrical, pneumatic or hydraulic instruments where corrosion is a determining factor.

Construction:

- Quality utility grade aluminium
- Continuously welded and ground smooth seams
- 1/4 turn latches
- Galvanized steel panel natural finish (unpainted)
- Grounding screw on mounting panel
- Grounding stud welded on inner cover surface
- ANSI/ASA61 grey polyester - epoxy textured powder coating inside out

Also Available:

- Aluminium, SS, galvanized steel
- Cutouts, hubs
- Special finishes & sizes

Standards:

- CSA certified 150359
- UL listed E109310
- CE

Hinged Lift-Off Stainless Steel Enclosures

TECHNICAL READOUT

Catalog No.	Dimensions			Panel		Weight lbs
	A	B	C	E	F	
S060404SS	6	4	4	4.875 x 2.875		4
S060604SS	6	6	4	4.875 x 4.875		5
S080604SS	8	6	4	6.875 x 4.875		6
S100804SS	10	8	4	8.875 x 6.875		10
S121005SS	12	10	5	10.875 x 8.875		15
S121206SS	12	12	6	10.875 x 10.875		17
S141206SS	14	12	6	12.875 x 10.875		21
S161406SS	16	14	6	14.875 x 12.875		26
S141208SS	14	12	8	12.875 x 10.875		22
S161410SS	16	14	10	14.875 x 12.875		28

Application:

Type 4-4x-12 / IP-65 stainless steel enclosure designed for INDOOR/OUTDOOR housing of electrical, pneumatic or hydraulic instruments where corrosion is a determining factor.

Construction:

- 16 gauge 304-4 stainless steel
- 14 gauge galvanized steel panel natural finish (unpainted)
- Continuously welded and ground smooth seams
- 1/4 turn latches
- Grounding screw on mounting panel
- Grounding stud welded on inner cover surface

Also Available:

- Cutouts, hubs
- Special finishes

Standards:

- CSA certified 150359
- UL listed E109310
- CE

