

Data and specifications subject to change without notice

Project name	Type
Order number	
Date	

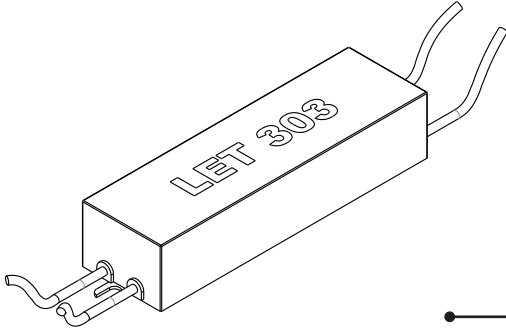

LET-303

REPLACEMENT MINI ELECTRONIC TRANSFORMER

SPECIFICATIONS

- ◆ UL and C-UL recognized, UL file number E164062
- ◆ Weight 11 ounces (330g)
- ◆ 35 °C max ambient temperature
- ◆ 90 °C max case temperature
- ◆ 120V 50/60Hz input, 2.5A
- ◆ 11.75Vac 30kHz output, 25.5A
- ◆ 300W max load
- ◆ 50W minimum load with or without dimmer
- ◆ 0.985 power factor
- ◆ Max THD 9%
- ◆ Waterproof potting
- ◆ Auto-reset electronic short circuit, overload protection and thermal cut-off @ 125 °C, fuse on primary

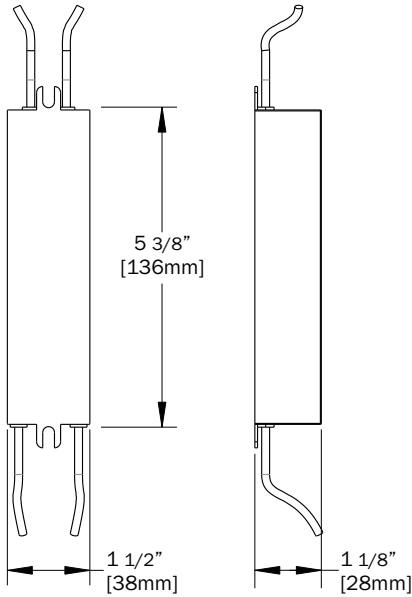

Output Voltage vs. Load at 120V

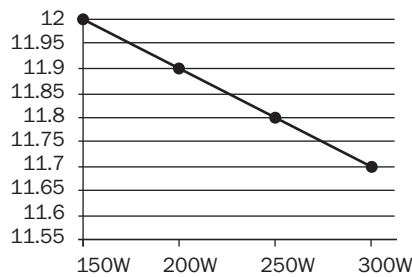

Output vs. Input at Max. Load

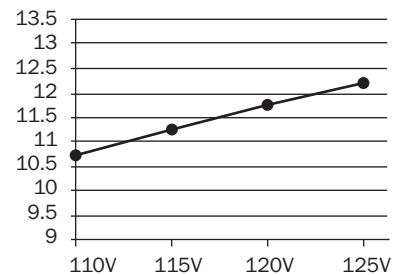

*Spec sheets are subject to change without notice