

Data and specifications subject to change without notice

Project name	Type
Order number	
Date	

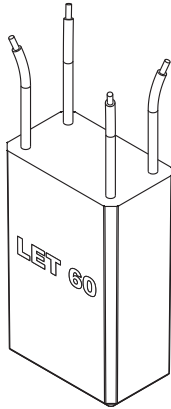

## LET-60 CLASS 2

### REPLACEMENT MINI ELECTRONIC TRANSFORMER

#### SPECIFICATIONS

- ◆ Approved by UL as Class 2 recognized component E193999
- ◆ Weight 3 ounces (86g)
- ◆ 50 °C max ambient temperature
- ◆ 90 °C max case temperature
- ◆ 120V 50/60Hz input, 0.5A
- ◆ 11.75Vac 40kHz output, 5A
- ◆ 60W max load
- ◆ 10W minimum load without dimmer
- ◆ 20W minimum load with dimmer
- ◆ 0.95 power factor
- ◆ Waterproof potting
- ◆ Electronic internal resettable protection, patented auto heat regulation that also automatically acts as over load protection, auto-reset thermal cut-off @ 125 °C

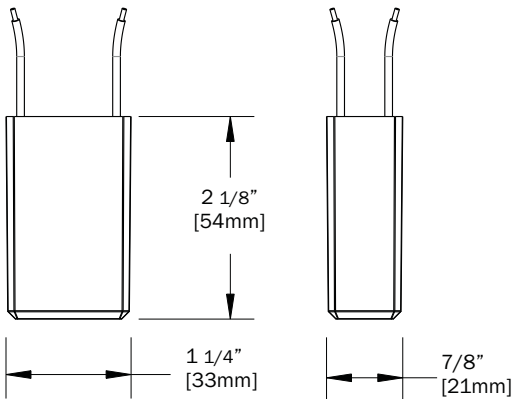

Output Voltage vs. Load at 120V

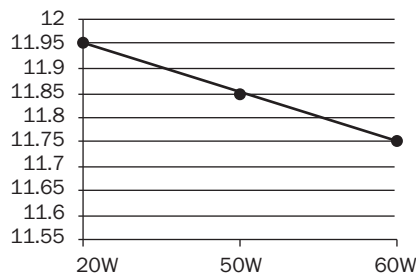

Output vs. Input at Max. Load

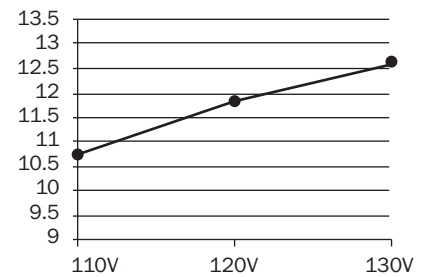

\*Spec sheets are subject to change without notice