



# 120V AC 10-Year Worry-Free Smoke & Carbon Monoxide Alarm

with 10-Year Sealed-in Battery Backup



Part Number **i12010S-CO-CA** Model **i12010SCOCA**  
**10-Year Limited Warranty**

**Combined Smoke & Carbon Monoxide Alarm**

**Intelligent Sensor Technology**

**Voice Warning**

**120V AC Direct Wire**

- Interconnects with up to 24 devices

**10-year Sealed Lithium Battery Backup**

**Hush®/Test Button**



## Features and Benefits

- **Combined Smoke & Carbon Monoxide Alarm** – A single unit can be installed where previously, two were needed. Reduces installation time and protects against both fire and carbon monoxide dangers.
- **Intelligent Sensor Technology** – Combines the detection capabilities of a ionization smoke sensor with that of an electrochemical sensor, which is used to detect CO. When either sensor notices a potential hazard, the alarm will adjust its smoke sensitivity to differentiate between a real hazard and a false one.
- **Voice Warning** – Announces the hazard type detected (in both English and French). Alarm announces “Fire! Fire!” when a smoke or fire hazard is detected and announces “Warning! Carbon Monoxide!” when a CO hazard is detected or “Low Battery!”.
- **120V Interconnectable** – Will interconnect with up to 24 other devices (18 of which can be initiating), including smoke alarms (limit of 12), CO and heat alarms.
- **10-Year Sealed Lithium Battery Backup** – Eliminates the need to replace the battery. No battery to replace for the life of the alarm (10 years). Battery backup automatically activates when the alarm is attached to mounting bracket.
- **Multi-function One Button Design includes:**
  - **Hush® Feature** – Temporarily silences nuisance alarms for approximately 9 minutes (smoke must be present before Hush® is activated).
  - **Test Feature** – Simultaneously tests the unit’s electronics and verifies alarm operation.
  - **Reset Feature** – Resets the carbon monoxide alarm
  - **Tamper Resist Feature** – Unit will lock to mounting bracket to deter theft or tampering.
  - **End of Life Notification** – Ten (10) years after unit is first powered, this alarm will chirp twice every 30 seconds to indicate it is time to replace the alarm.
  - **End of Life Hush Feature** – Allows you to temporarily silence End of Life chirp 3 days at a time for a maximum of 30 day life extension.

SIGNALISATION  
SIGNALLING



LISTED  
HOMOLOGUÉ

CSA-6.19-01

## Architectural and Engineering Specifications

The combination smoke and carbon monoxide alarm shall be Kidde model i12010SCOCA or approved equal. It shall be powered by 120V AC, 60Hz source with one 3V sealed lithium battery backup. The temperature operating range shall be between 4.4°C (40°F) to 37.8°C (100°F) and the humidity operating range shall be 10%–95% relative humidity, non-condensing.

The unit shall incorporate an ionization smoke sensor with nominal sensitivity of 0.75 ± 0.25 %/ft. The CO sensor shall be of a fuel cell design and shall meet the sensitivity requirements of CAN/CSA 6.19-01 - Residential carbon monoxide alarming devices.

The alarm can be installed on any standard single gang electrical box or a 4" octagon junction box. The electrical connection (to the alarm) shall be made with a plug-in connector. The unit shall provide optional tamper resistance that deters removal of the unit from the wall or ceiling. No additional pieces shall be required to activate this feature.

A maximum of 24 Kidde devices can be interconnected in a multiple station arrangement. The interconnect system must not exceed the limit of 18 initiating devices, of which 12 can be smoke alarms. With 18 initiating devices (smoke, heat, CO, etc), interconnected, it is still possible to interconnect 6 strobe lights and or relay modules.

The alarm shall include a test button that will electronically simulate the presence of smoke and CO and cause the unit to go into both modes of alarm. This sequence tests the unit's electronics to ensure proper operation.

The CO sensor will not alarm to levels of CO below 30 ppm and will alarm in the following time range when exposed to the corresponding levels of CO:

70 ppm CO Concentration	60 – 240 minutes
150 ppm CO Concentration	10 – 50 minutes
400 ppm CO Concentration	4 – 15 minutes

The combination alarm shall have two methods of warning for danger: a piezoelectric horn that is rated at 85 decibels at 10 feet and a voice warning that identifies the danger. For a CO incident, the horn will sound in four (4) short beeps followed by the verbal warning message "Warning Carbon Monoxide!". This continues until the unit is reset or the CO is eliminated. In a Smoke incident, the horn will sound three (3) long alarm beeps followed by the verbal warning message "FIRE!". This pattern is repeated until the smoke is eliminated. The red LED light will flash while in alarm/voice mode.

The unit shall incorporate 2 LED's. A green LED will be steady on when AC power is present, flash every 60 seconds when in the battery only mode, every second to indicate alarm memory, and every 2 seconds to indicate the Hush mode is active. A red LED will flash in unison with the sounder pattern.

The unit shall include the Hush® feature that silences the unit for approximately 9 minutes if a nuisance alarm condition occurs. The Green LED on the alarm will flash every 2 seconds while in Hush® and will automatically reset itself. It also provides voice announcement of "Hush Mode Activated" when Hush® is activated and "Hush Mode Cancelled" when the Hush cycle ends.

The unit shall also indicate a low battery warning utilizing each of the following methods: the red LED will flash and the unit will "chirp" one time, followed by the warning message "Low Battery!".

The unit shall at a minimum meet the requirements of CAN/CSA 6.19-01 and CAN/ULC-S531. It shall also include a 10-year manufacturer's limited warranty.

## Ordering Information

UPC: 0-47871-11608-9

Part Number	12 of 5	Pack Quantity	Case Dimensions (w x d x h centimeters)	Case Weight	Case/Skid
i12010S-CO-CA	100-47871-11608-6	6 units	16.5 cm x 34.5 cm x 16 cm	2.34 kg	126



Kidde Canada Inc.  
P.O. Box 40, Apsley, ON K0L 1A0  
1-800-880-6788  
www.kiddecanada.com

## Technical Specifications

<b>Power Source:</b>	120V AC, 60Hz, 45 mA max per alarm, sealed 3V lithium battery backup
<b>Sensors:</b>	Smoke: Photoelectric, CO: Electrochemical
<b>Audio Alarm</b>	85 dB at 10 ft
<b>Temperature Range:</b>	4.4°C (40°F) to 37.8°C (100°F)
<b>Humidity Range:</b>	10%-95% relative humidity, non-condensing
<b>Size:</b>	13 cm diameter x 3.8 cm depth
<b>Weight:</b>	0.2 kg
<b>Wiring:</b>	Quick connect plug with 6" pigtails
<b>Interconnects:</b>	Up to 24 Kidde devices (of which 18 can be initiating)
<b>Warranty:</b>	10-year limited

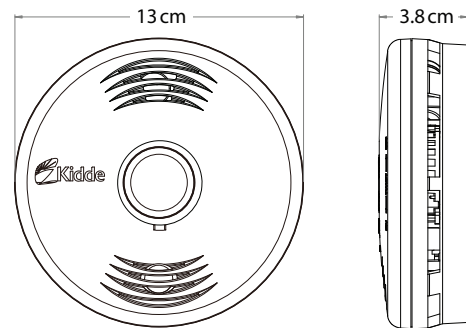

## Installation of Alarm

The combination alarm should be installed to comply with all local codes having jurisdiction in your area. Make certain all alarms are wired to a single, continuous (non-switched) power line, which is not protected by a ground fault interrupter. A maximum of 305 m (1000') of wire can be used in the interconnect system. Use standard CSA listed household wire as required by code.

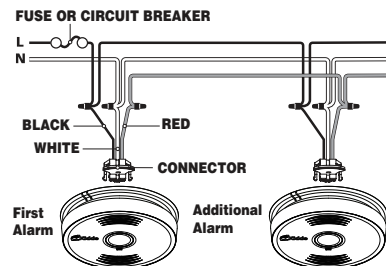

**Distributed by:**