

GENERAL INFORMATION

ACCESSORIES (for transformers listed in sections 3, 4, 7 and 11)

ANTI-VIBRATION PAD AND VIBRATION ISOLATOR KITS

All standard transformers come with installed internal vibration absorbing pads to minimize noise during operation. Optional external “anti-vibration” pad and “vibration isolator” (for higher noise dampening) kits can be used to reduce operating noise even further. All are resistant to industrial contaminants like oils, acids and alkalis.

ANTI-VIBRATION PAD KITS

Part No.	Case Style	Description
P1	NH Series	Set of four (4) rubber anti-vibration pads which replace the standard steel enclosure washers.
P2	NJ Series	

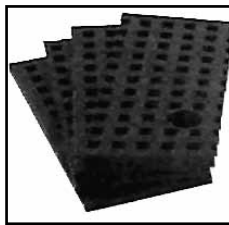

All Anti-Vibration Pad kits and Vibration Isolator kits contain a set of four (4) pads or isolators. Therefore only one kit is required per transformer.

VIBRATION ISOLATOR KITS

Part No.	Transformer Weight (Lb)	Description
NMP1	Up to 340 lbs	Set of four (4) molded neoprene and steel plate assemblies that virtually eliminate vibration noise between the transformer and the mounting surface.
NMP2	341 to 680 lbs	
NMP3	681 to 1040 lbs	
NMP4	1041 to 1740 lbs	
NMP5	1741 to 2330 lbs	
NMP6	2331 to 3450 lbs	
NMP7	3451 to 4690 lbs	



ACCESSORIES (for transformers listed in sections 8 and 10)

NQTW1 and NQTW2 Wall Mounting Kits

The **NQTW1** and **NQTW2** wall mounting kits are specifically designed for HPS commercial or industrial encapsulated (potted) distribution transformer units up to a maximum of 45kVA or 800 pounds (363 kg). These mounting kits are designed for encapsulated (potted) units only, no drip plate is included/required. Please contact HPS customer service if you have any questions.

Note: Always measure and secure mounting brackets to the wall surface first, then lift the transformer (using appropriate lifting equipment) onto the brackets and attach using minimum Grade 8 hardware.

Enclosure Case Style	Mounting Type	Wall Mounting Kit Part Number
NQ0-NQ8	Wall	Included
NQS10	Wall or Floor	NQTW2
NQT3-NQT6	Wall	Included
NQT7-NQT8	Wall or Floor	NQTW1
NQT9A	Floor	N/A
NQT9*	Wall or Floor	NQTW2

*Applies to HPS Fortress line only.

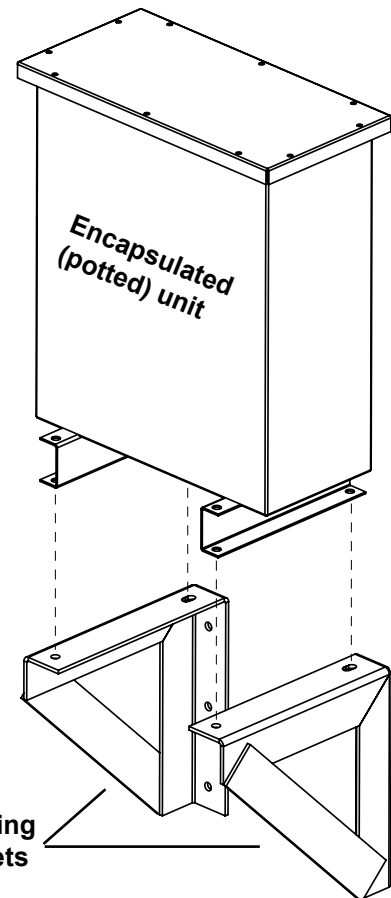

GENERAL INFORMATION

