

	PART No.	DESCRIPTION	SPECIFICATION
	<p>WR-6221K-82 16 Amp Rated KO Relay</p>	<ul style="list-style-type: none"> ▪ Knockout mount relay, 1 pole. ▪ Branch circuit, 16 Ampere latching relay. ▪ Screw terminals on load side and colored pre-stripped leads on control side. ▪ Manual operation lever and indicator built-in for convenient operation and status check at the panel. ▪ Relay fits to standard 1/2 inch pipe knock out (7/8 in hole). ▪ Use Douglas WEx series relay panels (sizes 6, 12, 24, 36, 48, 60 and 72). <p>NOTE: The WR-6221K-82 Relay is identical to the WR-6221 Relay except for the 16A contact rating.</p>	<p>Control Input</p> <ul style="list-style-type: none"> ▪ Class 2 circuit ▪ 0.350 A (350mA) ▪ 24 volt reversible polarity pulse ▪ Input terminals: #16 - #20 AWG <p>Output Contact Ratings</p> <ul style="list-style-type: none"> ▪ More than 30,000 operations @20 times / min. switch speed. ▪ UL Listings 16A 300 VAC 1920 W 120 VAC Tungsten 16A 300 VAC Ballast ▪ CSA Certifications 16A 347 VAC 1920 W 120 VAC Tungsten 16A 347 VAC Ballast ▪ Output terminals: #12 - #14 AWG

WR-6221K-82 Relay

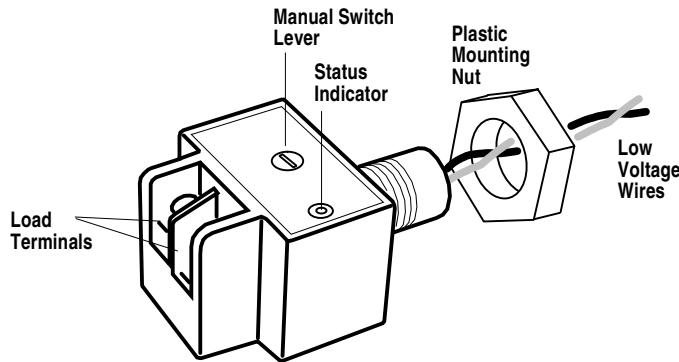

Environment

- Indoors, stationary, non-vibrating, non-corrosive atmosphere and non-condensing humidity.
- Ambient temperature: -20° to +120°F (-28° to +50°C)

DIMENSIONS & MOUNTING

- WR-6221K-82 relays mount through a 1/2" Knock out (7/8" hole). Douglas WEx series relay panels are made with barriers that have 1/2" KO's suited to WR-6221K-82 relays.

WR-6221K-82

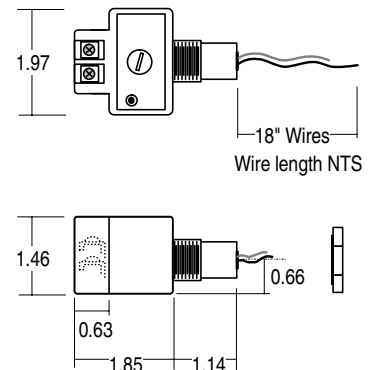

CONNECTIONS

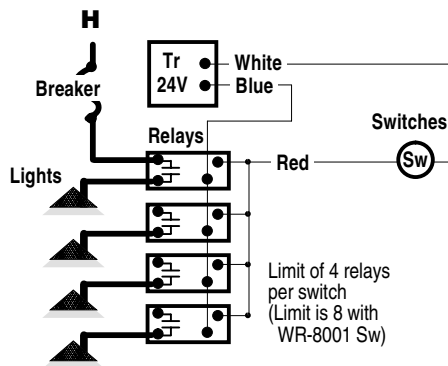
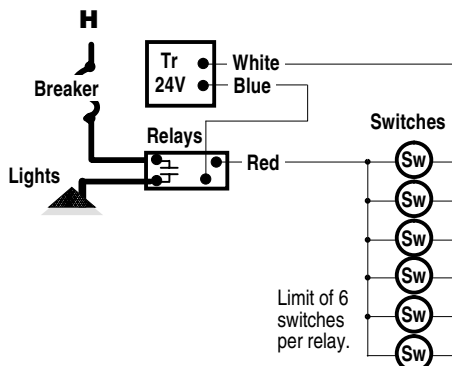

2-WIRE RELAY TECHNOLOGY

Douglas 2-wire relays utilize an ingenious control method that permits simple and minimal wiring. All functions for low voltage control: **on, off, indication** and **location** are provided with only a 2-wire connection of which one is often a common. All Douglas relays manufactured over the past 35 years utilize the same principle. Thus, any Douglas switching device is compatible with any model of Douglas relay.

Operational Principle

- A negative pulse turns the relay ON and a positive pulse turns it OFF. Using a diode, an AC signal can be rectified to turn the relay either ON or OFF. Douglas switches have 2 diodes built into the switch to provide the ON and OFF signals.
- The relay has 2 similar diodes built inside that are in series with the relay coil. The diodes in the relay act as gates for the switch signal.
- To turn the relay ON or OFF, the rocker switch completes the circuit by selecting the ON or OFF diode. If the diode selected is in the same direction as the gate diode in the relay, the relay will switch. If the gate diode is not in the correct direction, then nothing will happen since the relay is already in the correct state for the action selected by the switch. When the switch is released, a spring returns it to the central neutral position.
- Indication (ON state) and location (OFF state) are obtained by utilizing LED diodes built into the switch. Only the LED which is connected in the same direction as the gate diode in the relay will light. Although the LED current passes through the relay coil, it is not large enough to cause the relay to trip. However, there is a limit: the maximum number of LED switches that can be connected to the same relay is 6.
- For additional convenience (especially during installation) all standard models have a manual control lever and indicator permitting a non-electrical method of switching and status check at the panel.

Detailed 2-wire Relay / Switch Circuit

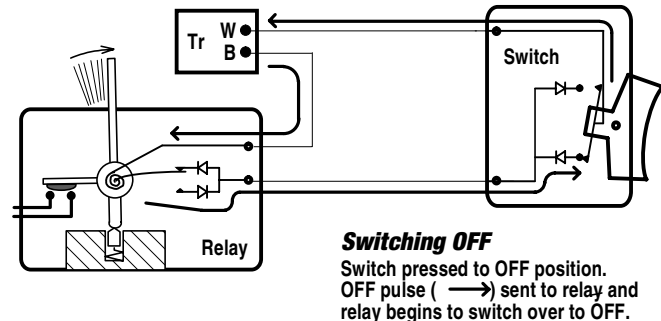
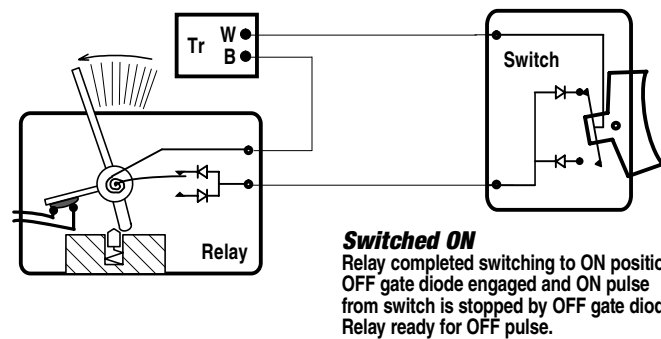
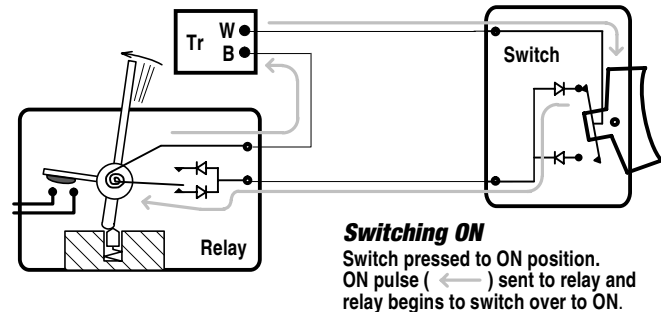
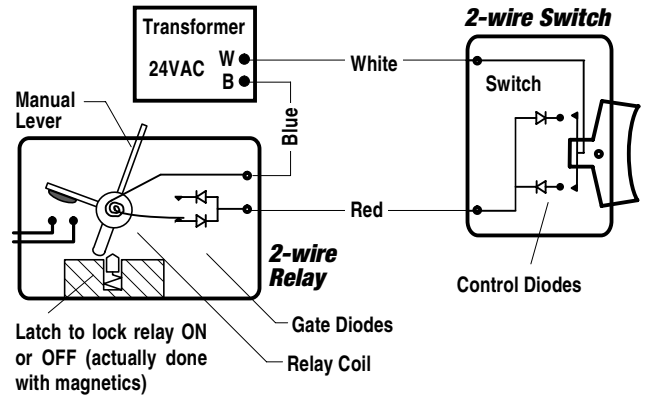

Detailed LED Switch Circuit *

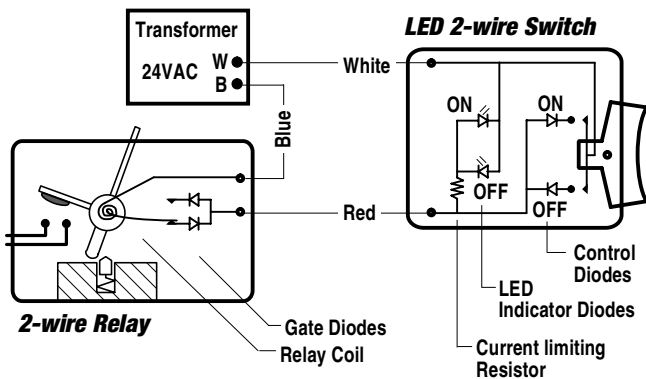

* LED Switch circuit actually not as shown. Switch is functionally similar except rocker switch is replaced with single push button.

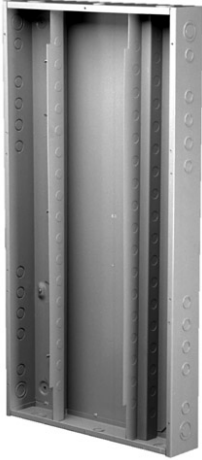
	PART No. WEx Panels	DESCRIPTION <ul style="list-style-type: none"> • Douglas WEx series relay panels are a versatile line of panels used for WR-6221K-82 KO mount relays. • Standard sizes range from 6 to 72 relays. • A barrier is provided to separate the line and low voltage areas of the panel. The barrier has knock outs and is specially shaped for mounting WR-6221K-82 relays and the transformer. • A DIN rail is installed in the center of the enclosure. The DIN rail provides mounting for optional controls. • Enclosure walls have knockouts located so that panels of same horizontal or vertical dimension can be joined with conduit nipples. • Panels that have hinged covers have a lockable latch. 	SPECIFICATION <ul style="list-style-type: none"> • Enclosures, barriers and covers are made of steel coated with ANSI/ASA 61 Grey. Coating is a heat fused, polyester epoxy finish applied on all surfaces. Certifications <ul style="list-style-type: none"> • UL listed, CSA approved • EEMAC/NEMA 1 Standard Options <ul style="list-style-type: none"> • Hinged, surface or flush covers. Covers are reversible for either left-to-right or right-to-left door opening. • Driphoods (surface mount only). • Voltage barriers to divide line voltage compartment for different line voltages.
---	-------------------------------	--	---

WEx Panel Numbering System

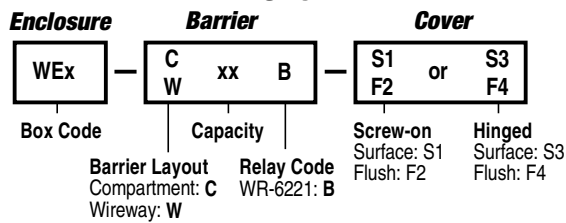

Compartment Style Barrier Layout

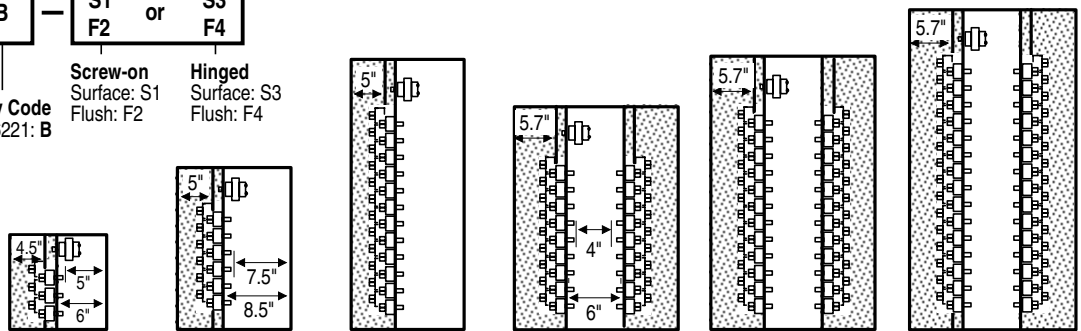

CAPACITY	6	12	24	36	48	60
PART No.	WE0 - C06B - **	WE1 - C12B - **	WE2 - C24B - **	WE3 - C36B - **	WE4 - C48B - **	WE6 - C60B - **
SIZE (H x W x D)	12 x 12 x 4.25	20 x 14 x 4.25	33 x 14 x 4.25	27 x 20 x 4.25	33 x 20 x 4.25	39 x 20 x 4.25

** Add cover style number at end of P/N

Wireway Style Barrier Layout

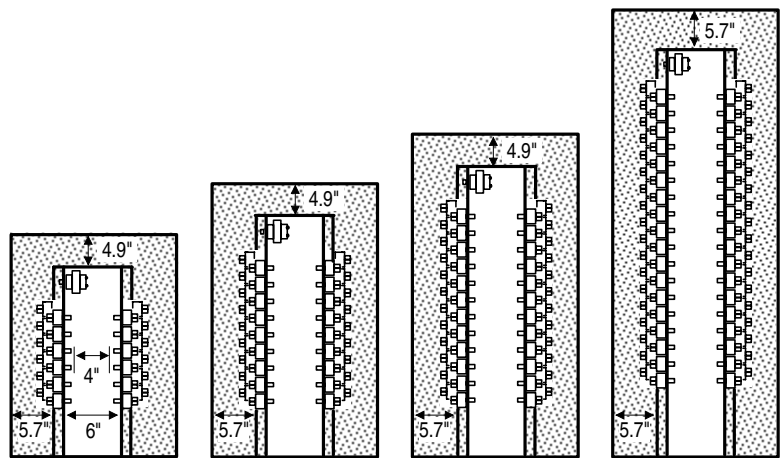

Symbols

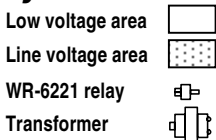

CAPACITY	24	36	48	72
PART No.	WE3 - W24B - **	WE4 - W36B - **	WE6 - W48B - **	WE8 - W72B - **
SIZE (H x W x D)	27 x 20 x 4.25	33 x 20 x 4.25	39 x 20 x 4.25	54 x 20 x 4.25

WEx Panels: Exploded View

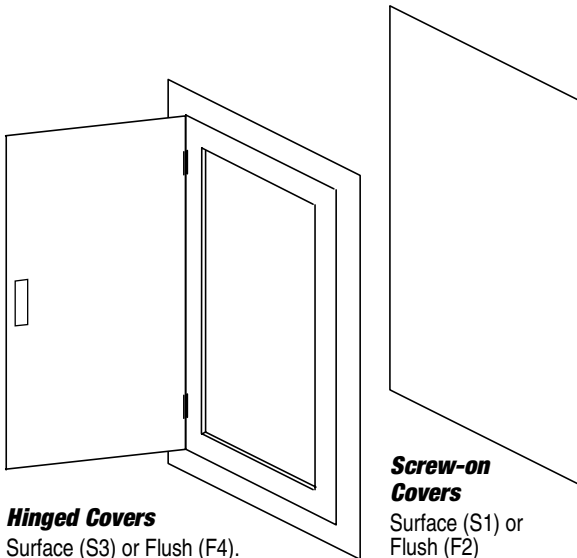

Hinged Covers

Surface (S3) or Flush (F4).
 Install right side up or upside down for right-to-left or left-to-right door.
 Cover latch can be locked if desired.
 The trim of the hinged cover covers over some of the line voltage wiring.
 A space is left open for access to the relay's manual control levers.

Screw-on Covers
 Surface (S1) or Flush (F2)

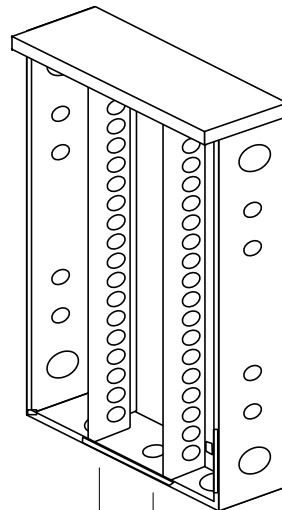

Drip Shields

Optional, surface cover panels only.

Enclosure & Barriers

Enclosures are supplied with barriers installed in either the compartment or wireway format. (See drawing below)
 Relays & transformers mount thru 1/2" KO's in barrier.
 Barrier is of special shape to accommodate WR-6221K-82 relay.

Stacking Panels

Panels of equal dimension on a side have matching KO pattern to provide easy stacking.

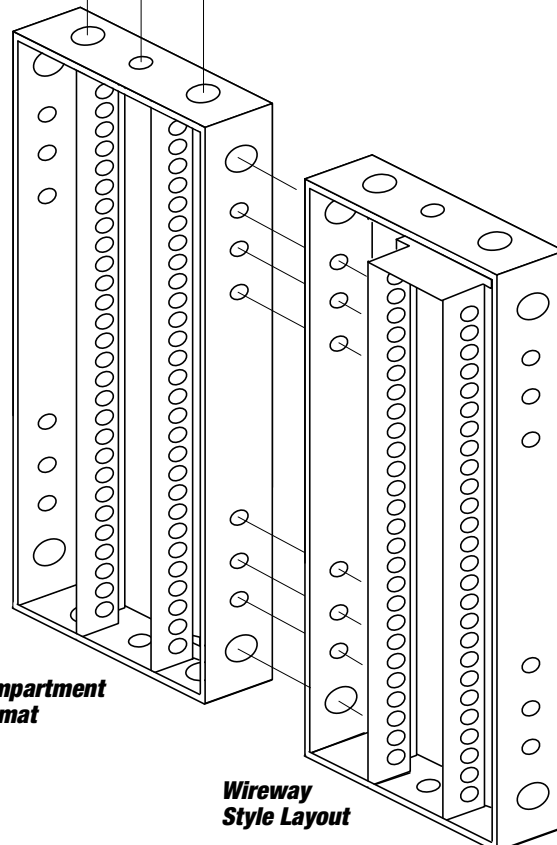

Compartment Format

Wireway Style Layout

INSTALLATION & ASSEMBLY

- WEx series relay panels for WR-6221K-82 KO mount relay are supplied with steel barrier(s) installed inside of the enclosure. The barrier(s) have 1/2" knock outs that are used to mount the transformer and WR-6221K-82 relays.
- WEx panels are primarily intended for field installation of relays and controls. WEx panels generally are not factory pre-assembled. To install the relay panel the following sequence is recommended:
 - 1) Mount the panel onto the wall and pull wires. It is recommended that all (or most) of the wires be pulled prior to installing any relays or other components. This will prevent component damage from the wire pulling operation.
 - 2) Relay line voltage terminals are sized for a maximum of 12AWG wire.
 For low voltage wiring 18AWG solid is recommended.
 - 3) Once the wires have been pulled, install relays into KO's. Make line connections to relays. To test circuit, turn circuit breaker off, use manual lever to turn relay on and then turn on the circuit breaker. This will help prevent relay contact welding due to dead shorts.
 - 4) Record which circuit the relay operates. Use blank panel schedule provided.
 - 5) Once the line circuits are connected and identified, install and wire low voltage controls (relay scanners, etc).