

BURNDY® Grounding Products

TYPE BCR-17 MOLDS

Horizontal Run and Tap Cables to Ground Rod

Type BCR-17 Molds are used to join horizontal run and tap cables to the top of a vertical ground rod.

Size range is #4 through 750 kcmil solid or concentric stranded copper conductors; 1/2" through 1" for the ground rod.

Contact BURNDY® Products for information on molds for conductors not listed below.

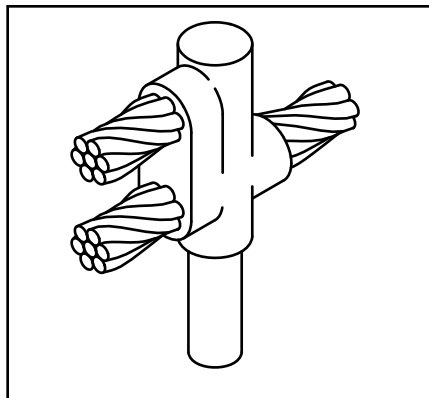

Cable		Mold Number	Price Key	Weld Metal	Handle Clamps
Grd Rod	Tap				
1/2"	#4	B-5416	4	90	B-106
	#2	B-6165	4	90	B-106
	#1	B-5830	4	90	B-106
	1/0	B-5940	4	115	B-106
	2/0	B-5850	4	150	B-106
	3/0	B-5833	4	200	B-106
	4/0	B-5380	4	200	B-106
5/8"	#4	B-5972	4	90	B-106
	#2	B-5935	4	115	B-106
	#1	B-5699	4	115	B-106
	1/0	B-5746	4	150	B-106
	2/0	B-5963	4	200	B-106
	3/0	B-5734	4	250	B-106
	4/0	B-5732	4	250	B-106
	250 kcmil	B-5722	5	2-150	B-107

- For sizes not listed, contact BURNDY® Products.
- Molds listed are for concentric stranded cable. Add suffix "-S" to mold number for solid conductors.
- Molds listed are for copperclad ground rods. For welding to steel, stainless steel or galvanized steel ground rods add suffix "-N" to mold number.
- For heavy duty molds, molds with wear plates or molds for Copperweld® cable, contact BURNDY® Products.
- For expedited service, contact BURNDY® Products.

Cable		Mold Number	Price Key	Weld Metal	Handle Clamps	
Grd Rod	Tap					
3/4"	#4	B-5698	4	90	B-106	
	#2	B-5294	4	115	B-106	
	#1	B-5390	4	115	B-106	
	1/0	B-6025	4	150	B-106	
	2/0	B-5738	4	200	B-106	
	3/0	B-6003	4	250	B-106	
	4/0	B-2566	4	250	B-106	
	250 kcmil	B-5904	5	2-150	B-107	
	300 kcmil	B-5857	5	2-200	B-107	
	350 kcmil	B-5777	5	2-200	B-107	
	500 kcmil	B-5961	5	3-200	B-106	
	1"	#4	B-5556	4	115	B-106
		#2	B-5555	4	150	B-106
#1		B-6048	4	150	B-106	
1/0		B-5992	4	200	B-106	
2/0		B-5877	4	250	B-106	
3/0		B-5821	5	2-150	B-107	
4/0		B-5820	5	2-150	B-107	
250 kcmil		B-5804	5	2-200	B-107	
300 kcmil		B-5803	5	500	B-107	
350 kcmil		B-5561	5	500	B-107	
500 kcmil		B-5515	6	3-250	B-107	
750 kcmil		B-5513	6	2-500	B-107	

- Required Tools:
 Handle Clamps (see chart for correct handles)
B38-0309-00 Flint Ignitor
 Other recommended accessories:
B38-3922-00 Mold Cleaning Brush (pg 93)
B38-0135-00 Cable Cleaning Brush (pg 93)
B38-0330-00 Cable Clamp (pg 92)
B38-0304-00 File (pg 94)

**For mold types or BURNDYWeld® items not shown,
 please contact factory.**

Throughout the catalog you will notice blue highlighted items. These are the most frequently ordered BURNDY® Products.

TYPE BCR-24 MOLDS

Horizontal Parallel Run Cables to Ground Rod

Type BCR-24 Molds are used to join horizontal parallel cables to the top of a vertical ground rod.

Size range is #4 through 750 kcmil solid or concentric stranded copper conductors; 1/2" through 1" for the ground rod.

Contact BURNDY® Products for information on molds for conductors not listed below.

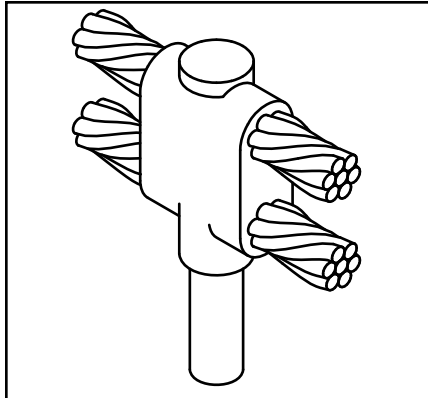

Cable		Mold Number	Price Key	Weld Metal	Handle Clamps
Grd Rod	Tap				
1/2"	#4	B-5640	4	115	B-106
	#2	B-5667	4	115	B-106
	#1	B-6002	4	115	B-106
	1/0	B-5767	4	150	B-106
	2/0	B-5604	4	200	B-106
	3/0	B-5560	4	250	B-106
	4/0	B-6766	4	250	B-106
5/8"	#4	B-6208	4	115	B-106
	#2	B-5702	4	150	B-106
	#1	B-5517	4	150	B-106
	1/0	B-5573	4	200	B-106
	2/0	B-8451	4	250	B-106
	3/0	B-2510	5	2-150	B-107
	4/0	B-5428	5	2-150	B-107
	250 kcmil	B-1212	5	2-200	B-107
	300 kcmil	B-2084	5	500	B-107
	350 kcmil	B-2558	5	500	B-107
	500 kcmil	B-2450	5	3-250	B-107

- For sizes not listed, contact BURNDY® Products.
- Molds listed are for concentric stranded cable. Add suffix "-S" to mold number for solid conductors.
- Molds listed are for copperclad ground rods. For welding to steel, stainless steel or galvanized steel ground rods add suffix "-N" to mold number.
- For heavy duty molds, molds with wear plates or molds for Copperweld® cable, contact BURNDY® Products.
- For expedited service, contact BURNDY® Products.

Cable		Mold Number	Price Key	Weld Metal	Handle Clamps
Grd Rod	Tap				
3/4"	#4	B-8011	4	115	B-106
	#2	B-2320	4	150	B-106
	#1	B-2235	4	150	B-106
	1/0	B-6051	4	200	B-106
	2/0	B-8802	4	250	B-106
	3/0	B-8726	5	2-150	B-107
	4/0	B-5677	5	2-150	B-107
	250 kcmil	B-8461	5	2-200	B-107
	300 kcmil	B-8428	5	500	B-107
	350 kcmil	B-6294	5	500	B-107
	500 kcmil	B-8214	5	3-250	B-107
1"	750 kcmil	B-8027	6	2-500	B-107
	#4	B-5330	4	150	B-106
	#2	B-5332	4	200	B-106
	#1	B-5333	4	200	B-106
	1/0	B-5334	4	250	B-106
	2/0	B-5335	5	2-150	B-107
	3/0	B-5336	5	2-200	B-107
	4/0	B-5337	5	2-200	B-107
	250 kcmil	B-5338	5	500	B-107
	300 kcmil	B-5341	5	3-200	B-107
	350 kcmil	B-5351	5	3-200	B-107
	500 kcmil	B-5352	6	2-500	B-107
	750 kcmil	B-5353	6‡	5-250	B-107

- Required Tools:
- Handle Clamps (see chart for correct handles)
 - B38-0309-00 Flint Ignitor
 - ‡ Crucible B-181 required
- Other recommended accessories:
- B38-3922-00 Mold Cleaning Brush (pg 93)
 - B38-0135-00 Cable Cleaning Brush (pg 93)
 - B38-0330-00 Cable Clamp (pg 92)
 - B38-0304-00 File (pg 94)

For mold types or BURNDYWeld® items not shown, please contact factory.

Throughout the catalog you will notice blue highlighted items. These are the most frequently ordered BURNDY® Products.