



ESL Series

6, 12 and 24 Volts
Steel Battery Units

Project/Location:
Contractor:
Date:
Prepared by:

Features

- Rugged steel cabinet with corrosion-resistant undercoating
- Removable front panel on cabinet provides easy access and allows unit to be mounted at ceiling height
- Solid-state pulse-type charger – current-limited, temperature-compensated, short-circuit proof and reverse-polarity protected.
- Unit comes standard with electronic lockout and brownout circuits
- Sealed dust-proof transfer relay, test switch and LED indicator lights
- Long-life, maintenance-free lead acid battery
- NEXUS® compatible

nexus®



Typical Specification

Supply and install a complete emergency lighting system as described herein and shown on the drawings.

The Emergi-Lite Smart Diagnostic micro-controller board shall supply the rated load for a minimum of a 1/2 hour to 87.5% of the rated battery voltage. The unit shall be rated 120V or 347V, 60 Hz and be CSA listed.

The charger shall be fully computer tested and its charge voltage factory set to $\pm 1\%$ tolerance. Chargers with field-adjusted potentiometers are not acceptable. A pulse-type charger shall be employed to promote long battery life and reduce the potential for grid corrosion. The charger shall provide a continuous high charge to recharge the battery, when the battery is at full capacity, the charger will shut-off. Periodically the charger shall provide a pulse of energy to keep the battery topped off. The pulse charger shall be current limited and precisely regulated by a micro-controller circuit, which samples the battery in relation to its temperature, state of charge and input voltage fluctuations. The charger shall be current limited, temperature compensated, short-circuit proof and reverse polarity protected. The unit shall be furnished with an electronic lockout circuit, which will connect the battery when the AC circuit is activated, and an electronic brownout circuit, which will activate the emergency lights when utility power dips below 75% of nominal voltage. A low voltage battery protection circuit shall be provided and will disconnect the load and circuitry from the fused output circuit when the battery reaches the end of discharge. The unit shall self-test for 1 minute every 30 days, 10 minutes on the 6th month and 30 minutes every 12 months. The unit shall be capable of full recharge in compliance with CSA specifications. The unit shall be furnished with sealed dust tight relay, a test switch and diagnostic LED indicator lights to continuously monitor the status of the unit: Battery Failure, Battery Disconnected, Charger Failure, Lamp Failure, Service Alarm, AC "ON", Charger High Rate. The unit shall come complete with tool-less emergency lighting heads requiring no tools to adjust or aim.

The unit shall be Emergi-Lite model: _____.

Wire Guards

460.0078-E	Wall Mount - "A" Cabinet
460.0081-E	Wall Mount - "B" Cabinet
460.0034-E	Wall Mount - "C" Cabinet

Power Consumption and Unit Rating

Model Number	AC Specs		Emergency power available for lamps				
			30min	1h00	1h30	2h00	4h00
06ESL36	120 to 347Vac	0.10 / 0.04 Amp	36	21	15	12	6
06ESL72		0.22 / 0.08 Amp	72	42	30	24	12
06ESL108		0.22 / 0.08 Amp	108	63	45	36	18
06ESL180		0.22 / 0.08 Amp	180	105	75	60	30
12ESL36		0.09 / 0.03 Amp	36	21	5	2	6
12ESL72		0.15 / 0.06 Amp	72	42	30	24	12
12ESL100		0.34 / 0.12 Amp	100	58	42	33	17
12ESL144		0.40 / 0.14 Amp	144	84	60	48	24
12ESL216		0.41 / 0.14 Amp	216	117	83	67	33
12ESL250		0.41 / 0.14 Amp	250	144	100	83	42
12ESL360		0.43 / 0.15 Amp	360	210	150	120	60
24ESL144		0.55 / 0.20 Amp	144	84	60	48	24
24ESL200	0.67 / 0.23 Amp	200	117	83	67	33	
24ESL288	0.67 / 0.23 Amp	288	168	120	96	48	
24ESL350	0.67 / 0.23 Amp	350	200	144	120	60	
24ESL432	0.67 / 0.23 Amp	432	250	180	144	72	
24ESL550	0.88 / 0.33 Amp	550	320	230	180	90	
24ESL720	0.88 / 0.33 Amp	720	420	300	240	120	

Project/Location: _____

Contractor: _____

Date: _____

Prepared by: _____

ESL Series

6, 12 and 24 Volts
Steel Battery Units



Dimensions

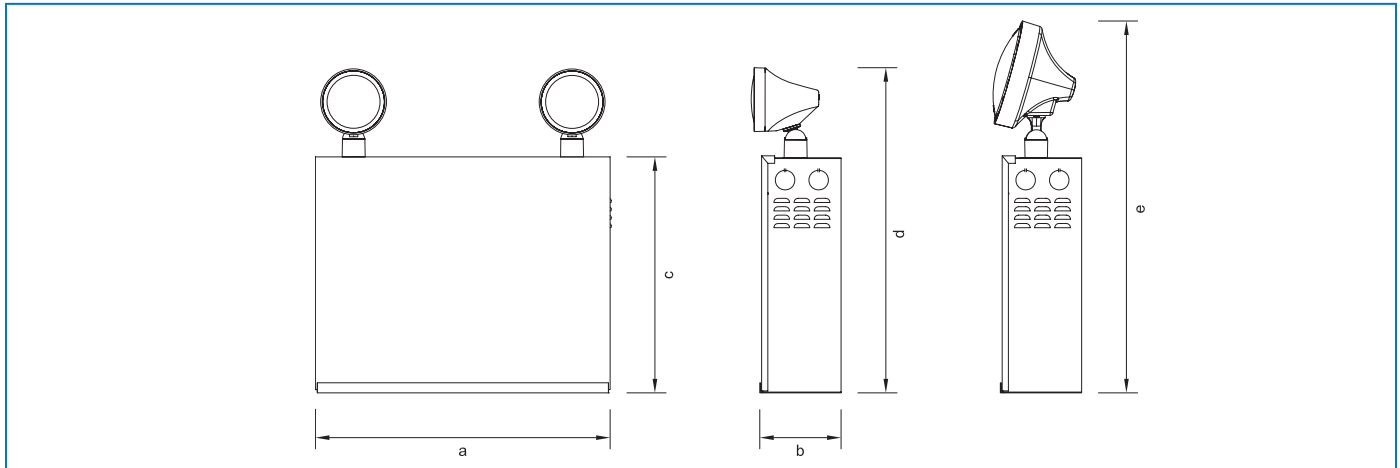

Dimensions

Cabinet	Dimensions				
	a	b	c	d	e
A	13¼ in. [33.4 cm]	3½ in. [9.2 cm]	10¼ in. [26.8 cm]	14¼ in. [36.8 cm]	16½ in. [42.2 cm]
B	16¼ in. [41.0 cm]	5½ in. [13.8 cm]	10¼ in. [26.1 cm]	14¼ in. [36.1 cm]	16½ in. [41.4 cm]
C	23¼ in. [58.8 cm]	5½ in. [13.8 cm]	10¼ in. [26.1 cm]	14¼ in. [36.1 cm]	16½ in. [41.4 cm]

Replacement Lamps

Ordering Code	Lamp Type	Voltage-Wattage
570.0016-E	Mini tungsten (MT9W)	6V - 9W
570.0025-E		12V - 9W
570.0045-E		24V - 9W

For the complete list please refer to the Lamp Chart on page 91

Ordering Information

Series	Capacity and Cabinet Size	Colour	Voltage	Options	Number of Heads	Head Style and Wattage
06ESL = 6 volts	36 = 36 watts (A) 72 = 72 watts (A) 108 = 108 watts (A) 180 = 180 watts (B)	blank = factory white BK = black	Blank = 120/347Vac input -2 = 277Vac input -8 = 240Vac input -9 = 220/50hz Vac input	A = ammeter CT = Cabtire D = time delay LW = twist-lock plug NEX = NEXUS® system interface** NEXRF = wireless NEXUS® system interface** P = light activated test switch T = lamp disconnect TB = DC terminal block TBAC = AC/DC terminal block TXC = remote test transmitter U = auto diagnostic UN = auto diagnostic non-audible V = voltmeter X = remote test receiver* FB6 = 6 circuit fuse panel	/0 = no head /1 = one head /2 = two heads /3 = three heads	M = mini tungsten, 6V, 12V, 24V - 9 watts, wedge base M18 = mini tungsten, 12V, 24V - 18 watts, wedge base MQ = mini halogen, 6V, 12V, 8 watts, quartz bi-pin MQ12 = mini halogen, 6V, 12V - 12 watts, quartz bi-pin MA = mini halogen, 12V - 20 watts, MR16 MI = mini halogen, 6V, 6 watts, MR16 MJ = mini halogen, 6V - 10 watts, MR16 MK = mini halogen, 12V - 12watts, MR16 MS = mini halogen, 24V - 12watts, MR16 MN = mini halogen, 24V-20watts, MR16 Blank = large tungsten, 6V, 12V, 24V, 9 watts, wedge base -18 = large tungsten, 12V, 24V - 18 watts, wedge base -25 = large tungsten, 6V, 12V, 24V- 25 watts, DCB Q = large halogen, 6V, 12V - 8 watts, quartz bi-pin Q12 = large halogen, 6V, 12V - 12 watts, quartz bi-pin Q20 = large halogen, 6V - 12V - 20 watts, quartz bi-pin Q55 = large halogen, 12V - 55 watts, quartz bi-pin Q70 = large halogen, 24V, 70 watts, quartz bi-pin S = large tungsten, 6V -9watts, sealed beam S18 = large tungsten, 6V, 12V -18 watts, sealed beam S25 = large tungsten, 6V, 12V - 25 watts, quartz sealed beam H = large halogen, 6V, 12V - 8watts, quartz sealed beam H12 = large halogen, 6V - 12V-12watts, quartz sealed beam H20 = large halogen, 6V - 20watts, quartz sealed beam
12ESL = 12 volts	36 = 36 watts (A) 72 = 72 watts (A) 100 = 100 watts (B) 144 = 144 watts(B) 216 = 216 watts (B) 250 = 250 watts (B) 360 = 360 watts (C) 650 = 650 watts* (C) 900 = 900 watts* (C)					
24ESL = 24 volts	144 = 144 watts (A) 200 = 200 watts (B) 288 = 288 watts (B) 350 = 350 watts (C) 432 = 432 watts (C) 550 = 550 watts (C) 720 = 720 watts (C)					

*Remote test transmitter needed.
**Not all options available with NEXUS®.
Consult your sales representative.

EXAMPLES: 06ESL108U/2M, 12ESL100U/2M, 24ESL144U/2M