



JMLC Series

Compact 6 and 12 Volts Steel Battery Unit

Project/Location: _____

Contractor: _____

Date: _____

Prepared by: _____

Features

- Compact steel cabinet with corrosion-resistant undercoating
- Quick and easy installation – pre-assembled cordset, no batteries or board to remove before installation
- Universal Spider knockout pattern for junction box mounting
- Fully automatic solid-state charger with test switch and AC-on pilot light
- Sealed dust-proof transfer relay circuit and low-voltage disconnect
- Long-life, maintenance-free sealed lead battery
- NEXUS® compatible



Typical Specification

The contractor shall install the Emergi-Lite **JMLC Series** battery units. The emergency lighting system shall consist of fully automatic equipment with two emergency lighting heads.

The charger shall be factory set with a charging voltage tolerance of $\pm 1\%$ to enable a longer battery life. The emergency light heads shall require no tools for adjusting or aiming. The metal cabinet shall be made of steel with anti-corrosion undercoating.

The unit equipped with the auto diagnostic micro-controller board shall self-test 1 minute every 30 days, 10 minutes the 6th month and 30 minutes every 12 months. The unit shall be supplied with a test switch and diagnostic LED indicator lights to continuously monitor the status of the unit: Battery Failure, Battery Disconnect, Charger Failure, Lamp Failure, Service Alarm, main voltage AC "ON", Charger High Rate.

The unit shall be CSA Certified to C22.2 no.141.

The unit shall be Emergi-Lite model: _____.

Dimensions

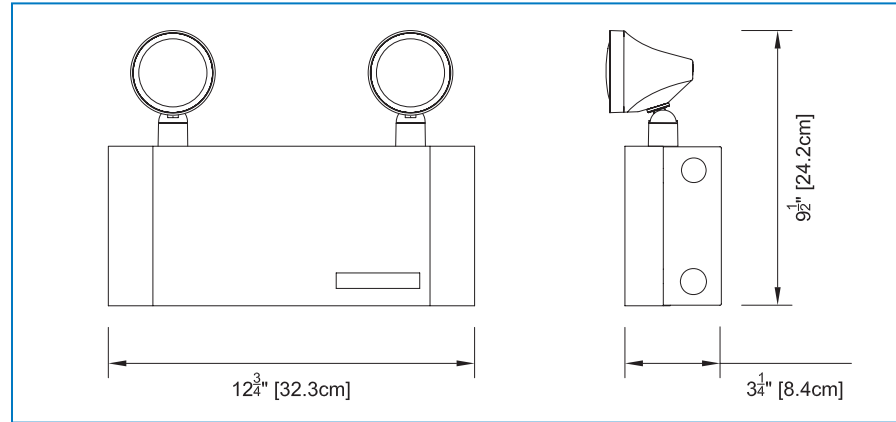

Wire Guards

460.0080-E	Wall Mount
------------	------------

Replacement Lamps

Ordering Code	Type	Voltage-Wattage
570.0012-E	Mini tungsten (MT9W)	6V - 9W
570.0025-E	Mini tungsten (MT9W)	12V - 9W

For the complete list please refer to the Lamp Chart on page 91

Power Consumption and Unit Rating

Model Number	AC Specs	Emergency power available for lamps					
		30min	1h00	1h30	2h00	4h00	
06JMLC27	120 / 347Vac	0.06 / 0.02 Amp	27	15	11	9	-
06JMLC44		0.18 / 0.06 Amp	44	26	18	15	7
06JMLC72		0.19 / 0.07 Amp	72	42	30	24	12
12JMLC44	120 / 347Vac	0.31 / 0.10 Amp	44	26	18	15	7
12JMLC72		0.31 / 0.10 Amp	72	42	30	24	12

Ordering Information

Series	Capacity	Colour	Voltage	Options	Number of Heads	Head Style and Wattage
06JMLC = 6 volts 12JMLC = 12 volts Commercial series	27 = 27 watts* 44 = 44 watts 72 = 72 watts	Blank = factory white BK = black	Blank = 120Vac c/w linecord -2 = 277Vac input -3 = 120/347Vac input -8 = 240Vac input*	Blank = no options CT = cab-tire LW = cab-tire twist lock plug U = auto diagnostic* UN = auto diagnostic, non-audible* NEX = NEXUS® system interface** NEXRF = wireless NEXUS® system interface**	/0 = no heads /1 = one head /2 = two heads	Blank = large tungsten, 6V, 12V - 9 watts, wedge base M = mini tungsten, 6V, 12V - 9 watts, wedge base MR18 = mini tungsten, 12V - 18 watts, wedge base MQ = mini halogen, 6V, 12V - 8 watt, quartz bi-pin MQ12 = mini halogen, 6V, 12V - 12 watt, quartz bi-pin MA = mini halogen, 12V - 20 watt, MR16 MI = mini halogen, 6V - 6 watt, MR16 MJ = mini halogen, 6V - 10 watt, MR16 MK = mini halogen, 12V - 12 watt, MR16 -18 = large tungsten, 12V - 18 watt, wedge base -25 = large tungsten, 6V, 12V - 25 watt, DCB
	Q = large halogen, 6V, 12V - 8 watt, quartz bi-pin Q12 = large halogen, 6V, 12V - 12 watt, quartz bi-pin Q20 = large halogen, 6V, 12V - 20 watt, quartz bi-pin S = large tungsten, 6V - 9 watt, sealed beam S18 = large tungsten, 6V, 12V - 18 watt, sealed beam S25 = large tungsten, 6V, 12V - 25 watt, sealed beam H = large halogen, 6V, 12V - 8 watt, quartz sealed beam H12 = large halogen, 6V, 12V - 12 watt, quartz sealed beam H20 = large halogen, 6V - 20 watt, quartz sealed beam					

EXAMPLE: 06JMLC44/2M