

Overview

Cylindrical fuses are standard in Europe. There are a range of different cylindrical fuse links and holders that comply with the standards IEC 60269-1, -2 and -3. They are suitable for use in industrial applications. In South West Europe they are also approved for use in residential buildings.

The cylindrical fuse holders are also approved to UL 512. The cylindrical fuse holders are tested and approved as fuse disconnectors in accordance with the switching device standard IEC 60947-3. They are not suitable for switching loads.

Cylindrical fuse holders can be supplied with or without signal detectors. In the case of devices with signal detectors, a small electronic device with LED is located behind an inspection window in the plug-in module. If the inserted fuse link is tripped, this is indicated by the LED flashing





An auxiliary switch, which can be laterally mounted, enables the forwarding of the switching state of the fuse holder, and thus an integration of the fuses in the automation processes.

Benefits

- Devices with pole number 1P+N are available in a single modular width. This reduces the footprint by 50 %.
- The sliding catch for type ranges 8 x 32 mm and 10 x 38 mm enables the removal of individual devices from the assembly.
- Space for a spare fuse in the plug-in module enables the fast replacement of fuses. This saves time and money and increases plant availability.
- A flashing LED signals that a fuse link has been tripped. This enables fast detection during runtime.

Technical specifications

		Cylindrical fuse links						
		3NW6 3..	3NW6 0..	3NW6 1..	3NW6 2..	3NW8 0..	3NW8 1..	3NW8 2..
Sizes	mm x mm	8 x 32	10 x 38	14 x 51	22 x 58	10 x 38	14 x 51	22 x 58
Standards		IEC 60269-1, -2, -3; NF C 60-200; NF C 63-210, -211; NBN C 63269-2, CEI 32-4, -12						
Operational class		gG					aM	
Rated voltages U_n	V AC	400 or 500						
Rated current I_n	A	2 ... 20	2 ... 32	4 ... 50	8 ... 100	0.5 ... 25	2 ... 50	10 ... 100
Rated breaking capacity								
• 500 V versions	kA AC	100						
• 400 V versions	kA AC	20						
Mounting position		Any, but preferably vertical						

		Cylindrical fuse holders			
		3NW7 3..	3NW7 0..	3NW7 1..	3NW7 2..
Sizes	mm x mm	8 x 32	10 x 38	14 x 51	22 x 58
Standards		IEC 60269-1, -2, -3; NF C 60-200, NF C 63-210, -211; NBN C 63269-2-1; CEI 32-4, -12			
Certifications	Acc. to UL Acc. to CSA	-- --	 	 	-- --
Rated voltage	U_n Acc. to UL/CSA	V AC V AC	400 400	690 600	
Rated current I_n	A AC	20	32	50	100
Rated breaking capacity	kA	20	100		
Switching capacity	• Utilization category	AC-20B (switching without load), DC-20B			
No-voltage changing	of fuse links	Yes			
Sealable	when installed	Yes			
Mounting position		Any, but preferably vertical			
Degree of protection	Acc. to IEC 60529	IP20, with connected conductors			
Terminals	with touch-protection acc. to BGV A3 at incoming and outgoing feeder	Yes			
Ambient temperature	°C	-5 ... +40, humidity 90 % at +20			
Conductor cross-sections					
• Rigid	mm ²	0.5 ... 10		2.5 ... 10	4 ... 10
• Stranded	mm ²	0.5 ... 10		2.5 ... 25	4 ... 50
• Finely stranded, with end sleeve	mm ²	0.5 ... 10		2.5 ... 16	4 ... 35
• AWG (American wire gauge)		--	10 ... 20	6 ... 10	--
Tightening torques	Nm	1.2		2.0	2.5

BETA Protecting Low-Voltage Fuse Systems



3NW cylindrical fuse systems

3

Sizes	I_n	U_n	DT	Order No.	Price per PU	PG	PU	PS*/ P. unit	Weight per PU approx.	
mm x mm	A	V AC					Unit(s)	Unit(s)	kg	
	22 x 58	10	500	B	3NW8 203-1		018	1	10/50	0.051
		12		B	3NW8 206-1		018	1	10/50	0.051
		16		B	3NW8 205-1		018	1	10/50	0.051
		20		B	3NW8 207-1		018	1	10	0.051
		25		B	3NW8 210-1		018	1	10	0.051
		32		B	3NW8 212-1		018	1	10	0.051
		40		B	3NW8 217-1		018	1	10	0.051
		50		B	3NW8 220-1		018	1	10	0.051
		63		B	3NW8 222-1		018	1	10	0.051
		80		B	3NW8 224-1		018	1	10	0.051
		100	400	B	3NW8 230-1		018	1	10	0.051

Number of poles	I_n	For fuse links of size	MW	DT	Order No.	Price per PU	PG	PU	PS*/ P. unit	Weight per PU approx.
	A	mm x mm						Unit(s)	Unit(s)	kg

Cylindrical fuse holders With signal detector

	1P	20	8 x 32	1	C	3NW7 314		018	1	1	0.059
		32	10 x 38	1	A	3NW7 014		018	1	1	0.059
		50	14 x 51	1.5	B	3NW7 112		018	1	1	0.095
		100	22 x 58	2	B	3NW7 212		018	1	1	0.145
	1P+N	20	8 x 32	1	C	3NW7 354		018	1	1	0.072
		32	10 x 38	1	A	3NW7 054		018	1	1	0.072
		50	14 x 51	3	B	3NW7 152		018	1	1	0.215
		100	22 x 58	4	B	3NW7 252		018	1	1	0.330
	2P	20	8 x 32	2	C	3NW7 324		018	1	1	0.123
		32	10 x 38	2	A	3NW7 024		018	1	1	0.123
	50	14 x 51	3	B	3NW7 122		018	1	1	0.195	
	100	22 x 58	4	B	3NW7 222		018	1	1	0.300	
	3P	20	8 x 32	3	C	3NW7 334		018	1	1	0.180
		32	10 x 38	3	A	3NW7 034		018	1	1	0.180
		50	14 x 51	4.5	B	3NW7 132		018	1	1	0.295
		100	22 x 58	6	B	3NW7 232		018	1	1	0.480
	3P+N	20	8 x 32	3	C	3NW7 364		018	1	1	0.193
		32	10 x 38	3	A	3NW7 064		018	1	1	0.193
	50	14 x 51	6	B	3NW7 162		018	1	1	0.315	
	100	22 x 58	8	B	3NW7 262		018	1	1	0.475	



Without signal detectors

	1P	20	8 x 32	1	A	3NW7 313		018	1	1	0.056
		32	10 x 38	1	▶	3NW7 013		018	1	1/12	0.056
		50	14 x 51	1.5	▶	3NW7 111		018	1	1	0.095
		100	22 x 58	2	▶	3NW7 211		018	1	1	0.145
	1P+N	20	8 x 32	1	A	3NW7 353		018	1	1	0.069
		32	10 x 38	1	▶	3NW7 053		018	1	1	0.069
		50	14 x 51	3	B	3NW7 151		018	1	1	0.215
		100	22 x 58	4	B	3NW7 251		018	1	1	0.330
	2P	20	8 x 32	2	A	3NW7 323		018	1	1	0.118
		32	10 x 38	2	▶	3NW7 023		018	1	1/6	0.118
	50	14 x 51	3	▶	3NW7 121		018	1	1	0.195	
	100	22 x 58	4	▶	3NW7 221		018	1	1	0.300	

BETA Protecting Low-Voltage Fuse Systems

3NW cylindrical fuse systems

3

Number of poles	I_n	For fuse links of size mm × mm	MW	DT	Order No.	Price per PU	PG	PU Unit(s)	PS*/ P. unit Unit(s)	Weight per PU approx. kg	
	A										
 3P	20	8 × 32	3	A	3NW7 333		018	1	1	0.172	
	32	10 × 38	3	▶	3NW7 033		018	1	1/4	0.172	
	50	14 × 51	4.5	▶	3NW7 131		018	1	1	0.295	
	100	22 × 58	6	▶	3NW7 231		018	1	1	0.691	
 3P+N	20	8 × 32	3	A	3NW7 363		018	1	1	0.185	
	32	10 × 38	3	▶	3NW7 063		018	1	1	0.185	
	50	14 × 51	6	A	3NW7 161		018	1	1	0.315	
	100	22 × 58	8	A	3NW7 261		018	1	1	0.475	
 Auxiliary switches	For indicating disconnection of the fuse link, solely for application of striker fuse links. For retrofitting using the factory-fitted brackets. Contact: 250 V AC, 5 A, Minimum contact load: 12 V, 25 mA										
	For fuse bases		14 × 51	0.5	B	3NW7 901		018	1	1	0.050
	For fuse bases		22 × 58		B	3NW7 902		018	1	1	0.050
											
For indicating the switching state of the fuse holder. For retrofitting using the factory-fitted brackets. Contact: 230 V AC, 6 A/110 V DC, 1 A Minimum contact load: 12 V, 25 mA Terminals 1.5 mm ² - 0.5 Nm											
	For fuse holders		10 × 38	0.5	B	3NW7 903		018	1	1	0.034

Dimensional drawings

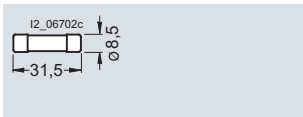

Sizes
8 × 32 mm

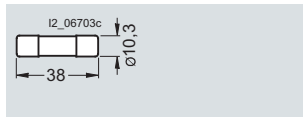

10 × 38 mm

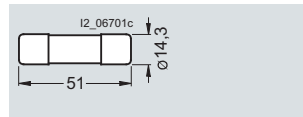

14 × 51 mm

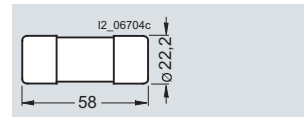

22 × 58 mm

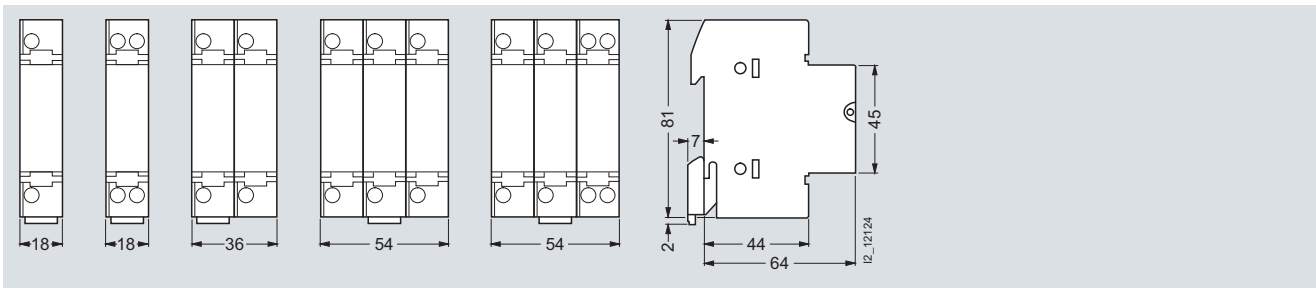

3NW7 0, 3NW7 3
1P 1P+N 2P 3P 3P+N

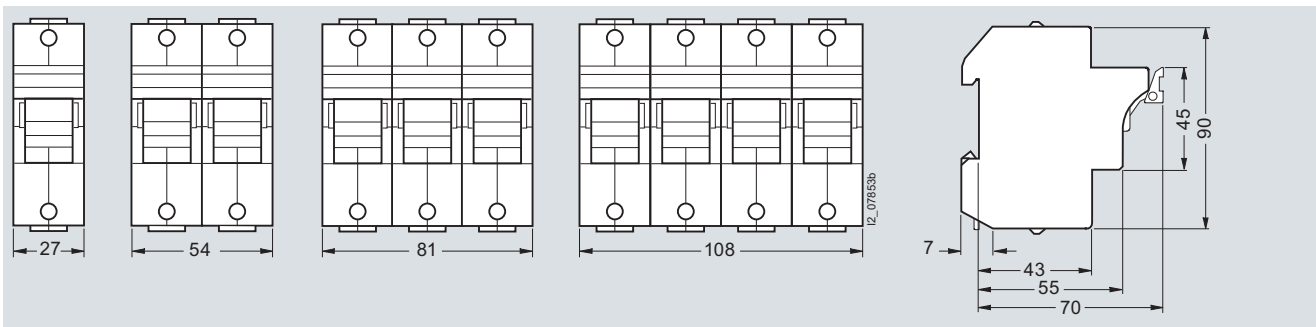

3NW7 1
1P 1P+N / 2P 3P 3P+N

* You can order this quantity or a multiple thereof.

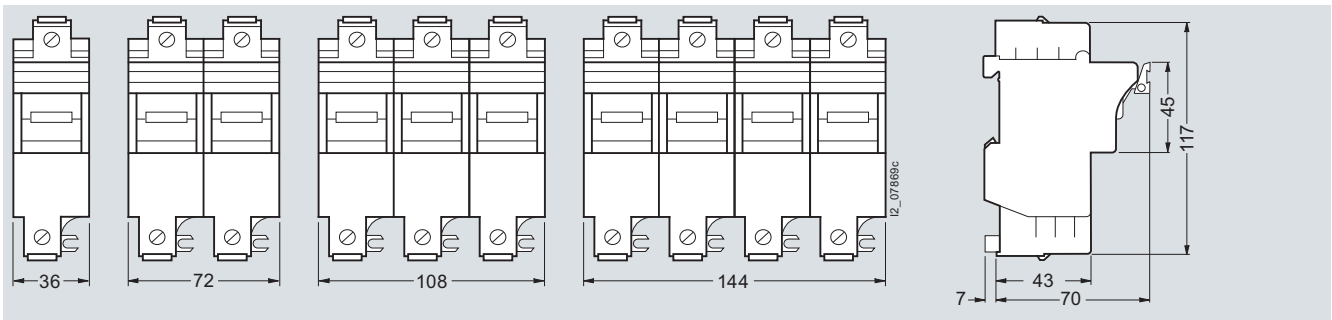

3NW7 2

1P

1P+N / 2P

3P

3P+N

Auxiliary switches

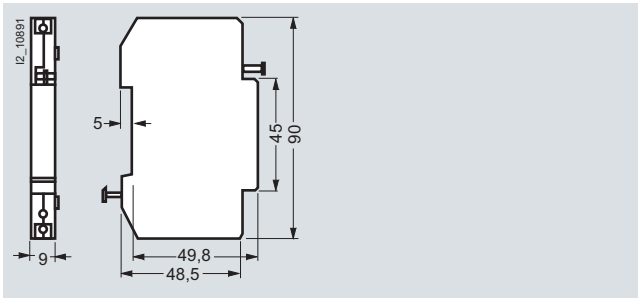
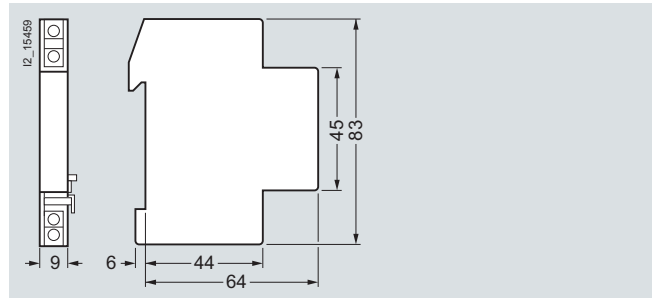
3NW7 901
3NW7 902

3NW7 903

Schematics

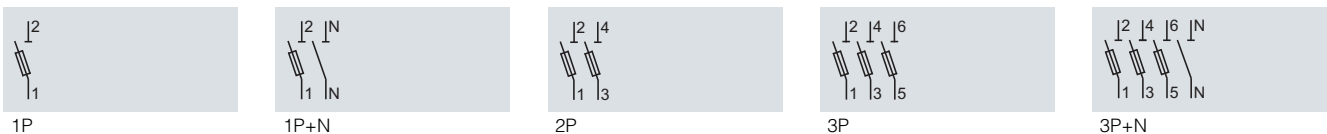

1P

1P+N

2P

3P

3P+N

Auxiliary switches

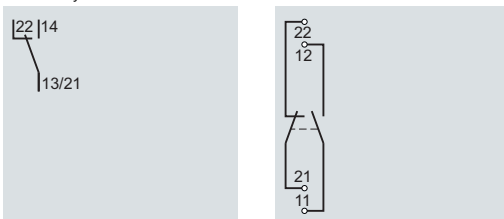
3NW7 901
3NW7 902

3NW7 903

More information

Installation

Fuse holders, sizes 8 mm × 32 mm and 10 mm × 38 mm have a sliding catch that enables the removal of individual devices from the assembly.

The infeed can be from the top or the bottom. Because the cylindrical fuse holders are fitted with the same anti-slip terminals at the top and the bottom, the devices can also be bus-mounted at the top or the bottom.

Auxiliary switches

Auxiliary switches are available for the cylindrical fuse holders. These are simply clipped onto the base using the factory-fitted brackets.

Sizes 8 mm × 32 mm and 10 mm × 38 mm:

The auxiliary switches support the remote display of the ON/OFF switching state of the fuse holder.

Sizes 14 mm × 51 mm and 22 mm × 58 mm:

The auxiliary switches support the remote display of fuse failure. However, fuse links with strikers are required for this function. When the fuse is tripped, a small striking pin – the striker – shoots out of the front of the fuse. Over an armature link in the auxiliary switch, the kinetic energy of this striker is used to switch a mini switch, which then initializes this signal over a floating contact.