

Load Feeders and Motor Starters for Use in the Control Cabinet

SIRIUS 3RA6 Compact Starters

General data

Overview

3RA6 fuseless compact starters and infeed system for 3RA6



3RA62 reversing starter

Integrated functionality

The SIRIUS 3RA6 compact starters are a generation of innovative load feeders with the integrated functionality of a motor starter protector, contactor and electronic overload relay. In addition, various functions of optional mountable accessories (e.g. auxiliary switches, surge suppressors) are already integrated in the SIRIUS compact starter.

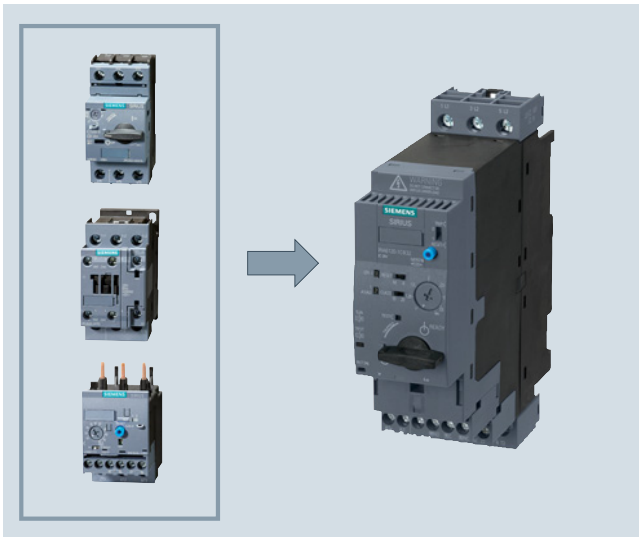

3RA6 compact starters with the integrated functionality of a motor starter protector, contactor and electronic overload relay.

Applications

SIRIUS compact starters can be used wherever standard three-phase motors or resistive loads up to 32 A (approx. 15 kW/400 V) are directly started or switched.

The compact starters are not suitable for the protection of DC loads.

Approvals according to IEC, UL, CSA and CCC standards have been issued for the compact starters.

Low variance of devices

Thanks to wide setting ranges for the rated current and wide voltage ranges, the equipment variance is greatly reduced compared to conventional load feeders.

Very high operational reliability

The high short-circuit breaking capacity and defined shut-down when the end of service life is reached means that the SIRIUS compact starter achieves a very high level of operational reliability that would otherwise have only been possible with considerable additional outlay. This sets it apart from devices with similar functionality.

Safe disconnection

The auxiliary switches (NC contacts) of the 3RA6 compact starters are designed as mirror contacts. This enables their use for safe disconnection – e.g. EMERGENCY STOP up to SIL 1 (IEC 62061) or PL c (ISO 13849-1) or, if used in conjunction with an additional infeed contactor, up to SIL 3 (IEC 62061) or PL e (ISO 13849-1).

Communications integration through AS-Interface

For the integration of communication via AS-Interface there is an AS-i add-on module available in several versions for mounting instead of the control circuit terminals on the SIRIUS compact starter.

The design of the AS-i add-on module permits a group of up to 62 feeders with a total of four cables to be connected to the control system. This reduces wiring work considerably compared to the parallel wiring method.

Communications integration using IO-Link

Up to four compact starters in IO-Link version (reversing and direct-on-line starters) can be connected together and conveniently linked to the IO-Link master through a standardized IO-Link connection. The SIRIUS 4SI electronic modules are used e.g. as IO-Link masters for connection to the SIMATIC ET 200S distributed I/O system.

The IO-Link connection enables a high density of information in the local range.

For details of the communication connection using IO-Link, [see page 2/98 onwards](#).

The diagnostics data of the process collected by the 3RA6 compact starter, e.g. short circuit, end of service life, limit position etc., are not only indicated on the compact starter itself but also transmitted to the higher-level control system through IO-Link.

Thanks to the optionally available operator panel, which can be installed in the control cabinet door, it is easy to control the 3RA6 compact starters with IO-Link from the control cabinet door.

Permanent wiring/easy replacement

Using the SIRIUS infeed system for 3RA6 ([see page 8/80](#)), it is possible to carry out the wiring in advance without a compact starter having to be connected.

A compact starter is very easily replaced simply by pulling it out of the device without disconnecting the wiring.

Even with screw connections or mounting on a standard mounting rail there is no need to disconnect any wiring (on account of the removable main and control circuit terminals) in order to replace a compact starter.

Consistent solution from the infeed to the motor feeder

The SIRIUS infeed system for 3RA6 with integrated PE bar is offered as a user-friendly possibility of feeding in summation currents up to 100 A with a maximum conductor cross-section of 70 mm² and connecting the motor cable directly without additional intermediate terminals.

Load Feeders and Motor Starters for Use in the Control Cabinet

SIRIUS 3RA6 Compact Starters

General data

Screw and spring-type terminals

The SIRIUS compact starters and the infeed system for 3RA6 are available with screw and spring-type terminals.



Screw terminals



Spring-type terminals

The terminals are indicated in the corresponding tables by the symbols shown on orange backgrounds.

System configurator for engineering

A free system configurator is available to reduce further the amount of engineering work for selecting the required compact starters and matching infeed.

Use of load feeders in conjunction with IE3 motors

Note:

For the use of SIRIUS 3RA6 compact starters in conjunction with highly energy-efficient IE3 motors, please observe the information on dimensioning and configuring, see "Configuration Manual for SIRIUS Controls with IE3 Motors", <https://support.industry.siemens.com/cs/ww/en/view/94770820>.

For more information, see Preface, page 5.

Types of infeed for the 3RA6 fuseless compact starters

On the whole four different infeed possibilities are available:

- Parallel wiring
- Use of 3-phase busbars (combination with SIRIUS motor starter protectors and SIRIUS contactors possible)
- 8US busbar adapters
- SIRIUS infeed system for 3RA6 (see page 8/80)

To comply with the clearance and creepage distances demanded according to UL 508 there are the following infeed possibilities:

| Type of infeed | Infeed terminal (according to UL 508, type E) | Type |
|-------------------------|--|---|
| Parallel wiring | Terminal block for "Self-Protected Combination Motor Controller (Type E)" | 3RV2928-1H |
| Three-phase busbars | Three-phase infeed terminal for constructing "Type E Starters", UL 508 | 3RV2925-5EB |
| Infeed systems for 3RA6 | Infeed on left, 50/70 mm ² , screw terminal with 3 sockets, outgoing terminal with screw/spring-type terminals incl. PE bar | 3RA6813-8AB (screw terminals), 3RA6813-8AC (spring-type terminals) |

SIRIUS 3RA6 compact starters

SIRIUS 3RA6 compact starters are universal motor feeders according to IEC 60947-6-2. As control and protective switching devices (CPS) they can connect, convey and disconnect the thermal, dynamic and electrical loads from short-circuit currents up to $I_q = 53$ kA, i. e. they are practically weld-free. They combine the functions of a motor starter protector, a contactor and an electronic overload relay in one enclosure. 45-mm-wide direct-on-line starters and 90-mm-wide reversing starters are available as variants.

The reversing starter version comes with not only an internal electrical interlock but also with a mechanical interlock to prevent simultaneous actuation of both directions of rotation.

The compact starters have isolating features in accordance with IEC 60947.2 and can be used as disconnecter units (main control switch according to EN 60204 or DIN VDE 0113). Isolation is effected by moving the actuator into the "OFF" position; disconnection by means of the control contacts is not enough.

3RA6 fuseless compact starters are available in five current setting ranges. The 3RA61 and 3RA62 have two control voltage ranges (AC/DC), and the 3RA64 and 3RA65 have one control voltage range (DC):

| Current setting range | At 400 V AC for three-phase motors Standard output P | Rated control supply voltage for | |
|-----------------------|---|----------------------------------|---|
| | | 3RA61, 3RA62 compact starters | 3RA64, 3RA65 compact starters for IO-Link |
| A | kW | V AC/DC | V DC |
| 0.1 ... 0.4 | 0.09 | 24 | 24 |
| 0.32 ... 1.25 | 0.37 | 110 ... 240 | |
| 1 ... 4 | 1.5 | | |
| 3 ... 12 | 5.5 | | |
| 8 ... 32 | 15 | | |

Note:

The 3RA1 load feeders can be used for fuseless load feeders > 32 A up to 100 A.

The SENTRON 3VL circuit breakers and the SIRIUS 3RT contactors can be used for fuseless load feeders > 100 A.

Operating conditions

The SIRIUS 3RA6 compact starters are suitable for use in any climate. They are intended for use in enclosed rooms in which no severe operating conditions (such as dust, caustic vapors, hazardous gases) prevail. Suitable covers must be provided for installation in dusty and damp locations.

The SIRIUS compact starters are generally designed to degree of protection IP20. The permissible ambient temperature during operation is -20 to +60 °C.

The rated short-circuit current I_{CS} according to IEC 60947-6-2 is 53 kA at 400 V.

Note:

The maximum permissible short-circuit currents of the device versions for the various line system configuration and currents are available on request from Technical Assistance:

Tel.: +49 (0) 911-895-5900

Email: technical-assistance@siemens.com

Overload tripping times

The tripping time in the event of overload can be set on the device to normal starting conditions (CLASS 10) and to heavy starting conditions (CLASS 20). As the breaker mechanism still remains closed after an overload, resetting is possible by either local manual reset or auto reset after three minutes cooling time.

With auto reset, there is no need to open the control cabinet.

Load Feeders and Motor Starters for Use in the Control Cabinet

SIRIUS 3RA6 Compact Starters

General data

Diagnostics options

The compact starter provides the following diagnostics options:

- With LEDs
 - Connection to the control voltage
 - Position of the main contacts
- With mechanical display
 - Tripping due to overload
 - Tripping due to short circuit
 - Tripping due to malfunction (end of service life reached because of worn switching contacts or a worn switching mechanism or faults in the control electronics)

These states can also be evaluated in the higher-level control system:

- With parallel wiring using the integrated auxiliary and signaling switches of the compact starter
- With AS-Interface or IO-Link in even greater detail using the respective communication interface

Four complement versions for 3RA61 and 3RA62 compact starters

- For standard mounting rail or screw fixing:
Basic version including 1 pair of main circuit terminals and 1 pair of control circuit terminals
- For standard mounting rail or screw fixing when using the AS-i add-on module:
Without control circuit terminals because the AS-i add-on module is plugged on instead
- For use with the infeed system for 3RA6:
Without main circuit terminals because they are supplied with the infeed system and the expansion modules
- For use with the infeed system for 3RA6 and AS-i add-on module:
Without terminal complement (also for reordering when replacing the compact starter)

The control circuit terminals are always required by the compact starters for IO-Link; the main circuit terminals depend on the use of the infeed system.

Article No. scheme

| Digit of the Article No. | 1st - 4th | 5th | 6th | 7th | 8th | 9th | 10th | 11th | 12th |
|---|----------------|--------------------------|--------------------------|--------------------------|--------------------------|--------------------------|--------------------------|--------------------------|--------------------------|
| SIRIUS 3RA6 compact starters | 3 R A 6 | | | | | | | | |
| Version (direct-on-line starter = 1, reversing starter = 2, direct-on-line starter for IO-Link = 4, reversing starter for IO-Link = 5, infeed system = 8, accessories = 9) | | <input type="checkbox"/> | | | | | | | |
| Details of accessories | | | <input type="checkbox"/> | <input type="checkbox"/> | | | | | |
| Connection method (0 = without terminals, 1 = screw terminals, 2 = spring-type terminals) | | | | | <input type="checkbox"/> | | | | |
| Setting range | | | | | | <input type="checkbox"/> | | | |
| Rated control supply voltage | | | | | | | <input type="checkbox"/> | <input type="checkbox"/> | |
| Terminals complement variant | | | | | | | | | <input type="checkbox"/> |
| Special versions | | | | | | | | | |
| Example | 3 R A 6 | 1 | 2 | 0 | - | 0 | A | B | 3 0 |

Note:

The Article No. scheme is presented here merely for information purposes and for better understanding of the logic behind the article numbers.

For your orders, please use the article numbers quoted in the catalog in the Selection and ordering data.

More components of the 3RA6

Apart from the control supply voltage, "Overload" (1 CO) and "Short circuit / Function fault" (1 NO) signaling contacts are already integrated into the 3RA61/3RA62 – and lockable via two 6-pole removable control circuit terminals. The 3RA61 has two auxiliary contacts (1 NO + 1 NC) for displaying the position of the main contacts. Unlike the 3RA61 direct-on-line starter, the 3RA62 reversing starter has one auxiliary contact (1 NO) per direction of rotation per main contact.

Available for the 3RA61 and 3RA64 direct-on-line starters is a slot for an optional auxiliary switch block (optionally 2 NO, 2 NC or 1 NO + 1 NC) and for the 3RA62 and 3RA65 reversing starters there are two slots (for auxiliary switch blocks, see "Accessories" on page 8/73).

Positively-driven operation of the auxiliary contacts

Positively-driven operation between individual auxiliary circuits exists for the compact starter in the version as a direct-on-line starter for parallel wiring (3RA61) between the auxiliary circuits of the NC contacts (NC 21-22) and the NO contacts (NO 13-14) in the basic unit.

In addition, the optional auxiliary switch block offers positively driven contacts in the 3RA6913-1A version, each with one normally closed contact and one normally open contact.

Load Feeders and Motor Starters for Use in the Control Cabinet

SIRIUS 3RA6 Compact Starters

General data

Benefits

Advantages through energy efficiency

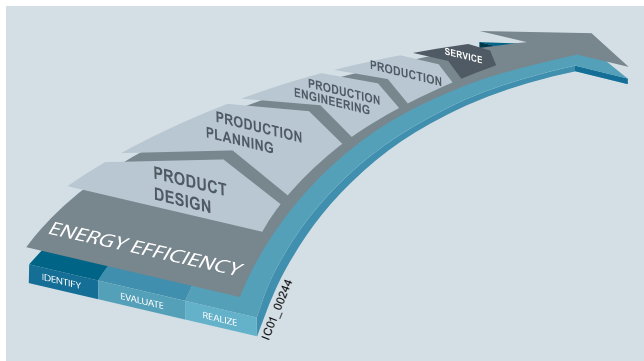

Overview of the energy management process

We offer you a unique portfolio for industrial energy management, using an energy management system that helps to optimally define your energy needs. We split up our industrial energy management into three phases – identify, evaluate, and realize – and we support you with the appropriate hardware and software solutions in every process phase.

The innovative products of the SIRIUS industrial controls portfolio can also make a substantial contribution to a plant's energy efficiency (see www.siemens.com/sirius/energysaving).

With the 3RA6 compact starters, control cabinets heat up less because power losses have been minimized by operation:

- Lower intrinsic power loss (than comparable motor feeders with thermal overload trips) thanks to electronic current analysis
- Lower power losses (than conventional load feeders) because there is only one switching point for short circuit and operational switching
- Lower control circuit power losses (compared with conventional switching devices) as a result of electronic control of switching points
- Thanks to the above advantages, additional energy savings are possible because less cooling is required (and a more compact design is possible)

Product advantages

The SIRIUS 3RA6 compact starters offer a number of benefits:

- Compact design saves space in the control cabinet
- Little planning and assembly work and far less wiring thanks to a single complete unit with one article number
- Low variance and therefore low stock levels, with two wide voltage ranges and five wide setting ranges for the rated current
- High plant availability through integrated functionalities such as prevention of main contact welding and disconnection at end of service life
- Enhanced productivity through automatic device reset in case of overload and differentiated detection of overload and short circuit
- Easy checking of the wiring and testing of the motor direction prior to start up thanks to optional "control kits"
- Speedy replacement of devices thanks to removable terminals with spring-type and screw connections in the main and control circuit
- Efficient power distribution through the related SIRIUS infeed system for 3RA6
- Direct connection of the motor feeder cable to the SIRIUS infeed system for 3RA6 thanks to integrated PE bar
- Connecting and looping through incoming feeders up to a cross-section of 70 mm²
- When using the infeed system for 3RA6, possibility of directly connecting the motor cable without intermediate terminals
- Integration in Totally Integrated Automation thanks to the optional connection to AS-Interface or IO-Link

The SIRIUS 3RA6 compact starters create the basis for high-availability and future-proof machine concepts.

Load Feeders and Motor Starters for Use in the Control Cabinet

SIRIUS 3RA6 Compact Starters

General data

Technical specifications

| Type | | 3RA61 | 3RA62 | 3RA64 | 3RA65 |
|---|---|-------|--|--|----------------|
| Size | | S0 | | | |
| Number of poles | | 3 | | | |
| Mechanics and environment | | | | | |
| Mounting dimensions (W x H x D) | | mm | 45 x 170 x 165 | 90 x 170 x 165 | 45 x 170 x 165 |
| <ul style="list-style-type: none"> Screw terminals Spring-type terminals | | mm | 45 x 191 x 165 | 90 x 191 x 165 | 45 x 191 x 165 |
| Depth from standard mounting rail | | mm | 160 | | |
| Permissible ambient temperature | | °C | -20 ... +70, restriction as from 60 depending on design | | |
| <ul style="list-style-type: none"> During operation (for permissible operational current, see the following section "Electrical specifications") During storage During transport | | °C | -55 ... +80 | | |
| | | °C | -55 ... +80 | | |
| Permissible mounting position | | | | | |
| Shock resistance (sine-wave pulse) | | | $a = 60 \text{ m/s}^2 = 6 \text{ g}$ with 10 ms; for every 3 shocks in all axes | | |
| Vibratory load | | | $f = 4 \dots 5.8 \text{ Hz}$; $d = 15 \text{ mm}$; $f = 5.8 \dots 500 \text{ Hz}$; $a = 20 \text{ m/s}^2$; 10 cycles | | |
| Degree of protection | Acc. to IEC 60947-1 | | IP20 | | |
| Installation altitude | | m | Up to 2 000 above sea level without restriction | | |
| Relative air humidity | | % | 10 ... 90 | | |
| Degree of pollution | | | 3 | | |
| Electrical specifications | | | | | |
| Device standard | | | IEC 60947-6-2 | | |
| Maximum rated operational voltage U_e | | V | 690 | | |
| | | V | 400 at 3RA6250-E... and 3RA6500-E... (Reversing starter 32 A designs) | | |
| Rated frequency | | Hz | 50/60 | | |
| Rated insulation voltage U_i (Pollution degree 3) | | V | 690 | | |
| Rated impulse withstand voltage U_{imp} | | kV | 6 | | |
| Rated operational current $I_e^{(1)}$ | 0.1 ... 0.4 A | A | 0.4 | | |
| And setting range for overload release | 0.32 ... 1.25 A | A | 1.25 | | |
| | 1 ... 4 A | A | 4 | | |
| | 3 ... 12 A | A | 12 | | |
| | 8 ... 32 A | A | 32 | | |
| Permissible operational current of the compact starter⁽²⁾ | When several compact starters are mounted side-by-side in the infeed system for 3RA6 (for more details on the various design variants, see System Manual "SIRIUS 3RA6 Compact Feeders", https://support.industry.siemens.com/cs/ww/en/view/27865747) | | | | |
| | • For a control cabinet inside temperature of +40 °C | % | 100 | | |
| | • For a control cabinet inside temperature of +60 °C | % | 80 | | |
| | • For a control cabinet inside temperature of +70 °C | % | 60 | | |
| Trip class (CLASS) | Acc. to IEC 60947-4-1, EN 60947-4-1 (VDE 0660 Part 102) | | 10/20 | | |
| Overload function | | | 1:4 | | |
| Ratio of lower to upper current mark | | | | | |
| Rated service short-circuit breaking capacity I_{CS} at 50/60 Hz, 400 V AC | | kA | 53 | | |
| Rated service short-circuit breaking capacity I_{CSIT} at 50/60 Hz 400/690 V AC in IT systems | | kA | 1.5 | | |
| Power loss P_V max of all main current paths | 0.4 A | mW | 10 | | |
| Dependent on rated current I_e | 1.25 A | mW | 100 | | |
| (upper setting range) | 4 A | W | 1 | | |
| | 12 A | W | 1.8 | | |
| | 32 A | W | 5.4 | | |
| Max. switching frequency | AC-41 | 1/h | 750 | | |
| | AC-43 | 1/h | 250 | | |
| | AC-44 | 1/h | 15 | | |
| No-load switching frequency | | 1/h | 3 600 | 3 600, depending on the IO-Link communication time | |
| Touch protection | Acc. to DIN VDE 0106, Part 100 | | Finger-safe | | |

¹⁾ For use of 3RA6 compact starters in conjunction with highly energy-efficient IE3 motors, please observe the information on dimensioning and configuring in the "Configuration Manual for SIRIUS Controls with IE3 Motors", see <https://support.industry.siemens.com/cs/ww/en/view/94770820>.

²⁾ Details about installation conditions and the use of the compact starters, and particularly about the derating of the rated current, can be found in the System Manual "SIRIUS Compact Starters and Accessories".

Load Feeders and Motor Starters for Use in the Control Cabinet

SIRIUS 3RA6 Compact Starters

General data

| Type | | 3RA61 | 3RA62 | 3RA64 | 3RA65 |
|--|--|--|-----------------------------|-------------------------|-----------------------------|
| Size | | S0 | | | |
| Number of poles | | 3 | | | |
| Electrical specifications (continued) | | | | | |
| Isolating features of the compact starter | Acc. to IEC 60947-3 | ✓ Isolation is assured only by moving the actuator into the "OFF" position. | | | |
| Main and EMERGENCY-STOP switch characteristics of the compact starter and accessories | Acc. to IEC 60204 | ✓ | | | |
| Protective separation | Acc. to IEC 60947-2 | | | | |
| Control circuit to auxiliary circuit | | V | Up to 400 | | |
| • Horizontal standard mounting rail | | V | Up to 250 | | |
| • Other mounting position | | | | | |
| Auxiliary circuit to auxiliary circuit | | V | Up to 400 | | |
| • Horizontal standard mounting rail | | V | Up to 250 | | |
| • Other mounting position | | | | | |
| Main circuit to auxiliary circuit | | V | Up to 400 | | |
| • Any mounting position | | | | | |
| EMC interference immunity | Acc. to IEC 60947-1 | Corresponds to degree of severity 3 | | | |
| Conducted interference | BURST Acc. to IEC 61000-4-4 | | | | |
| • In the main circuit | | kV | 4 | 4 | |
| • In the auxiliary circuit | | kV | 3 | 2 | |
| Conducted interference | SURGE Acc. to IEC 61000-4-5 | | | | |
| • In the main circuit | | kV | 4 | 2 | |
| - Conductor - Ground | | kV | 2 | 1 | |
| • In the auxiliary circuit | | kV | 2 | 0.5 ¹⁾ | |
| - Conductor - Ground | | kV | 1 | 0.5 ¹⁾ | |
| - Conductor - Conductor | | | | | |
| Auxiliary switches | | | | | |
| • Integrated | | | 1 NO + 1 NC | 2 NO | 1 NO + 1 NC 2 NO |
| - Position of the main contacts | | | 1 CO/1 NO | | |
| • Expandable | | | 2 NO, 2 NC, 1 NO, 1 NC | | |
| - Position of the main contacts | | | | | |
| Surge suppressors | | Integrated (Varistor) | | | |
| Electromagnetic operating mechanisms | | | | | |
| Control voltage | | V | 24 AC/DC | | 24 DC |
| | | V | 110 ... 240 AC/DC | | -- |
| Frequency | At AC | Hz | 50/60 (±5 %) | | |
| Operating range | | | 0.7 ... 1.25 U _s | | 0.85 ... 1.2 U _s |
| No-load switching frequency | | 1/h | 3 600 | | |
| Line protection | At 10 kA | mm ² | 2.5 | | |
| | At 50 kA | mm ² | 4 | | |
| Shock resistance | | | | | |
| • Breaker mechanism OFF | | g | 25 | | |
| • Breaker mechanism ON | | g | 15 | | |
| Normal switching duty | | | | | |
| Making capacity | | | 12 x I _n | | |
| Breaking capacity | | | 10 x I _n | | |
| Switching capacity dependent on rated current | Up to 12 A | kW | 5.5 | | |
| | Up to 32 A | kW | 15 | | |
| Endurance in operating cycles | | | | | |
| • Electrical endurance | At I _e = 0.9 x I _n and 400 V | | 3 ... 10 000 000 | 2 x 3 ... 10 000 000 | 3 000 000 2 x 1 500 000 |

✓ Function available

¹⁾ To maintain maximum interference immunity in a harsh electromagnetic environment, additional overvoltage protection should be provided in the control circuit. A suitable answer is for example the Dehn Blitzductor BVT AD 24 V, Art. No. 918 402 or an equivalent protection element.

Manufacturer:
DEHN+SÖHNE GmbH+Co. KG
Hans-Dehn-Straße 1
Postfach 1640
D-92306 Neumarkt.

Load Feeders and Motor Starters for Use in the Control Cabinet

SIRIUS 3RA6 Compact Starters

General data

| Type | | 3RA6120-□B3., 3RA6250-□B3. □ = A, B, C or D Rated operational current ≤ 12 A | | | | 3RA6120-EB3., 3RA6250-EB3. Rated operational current 32 A | | | |
|--|----|--|--------|--------|--------|--|--------|--------|--------|
| Rated control supply voltage | V | 24 AC | | 24 DC | | 24 AC | | 24 DC | |
| Inrush peak current | A | 0.59 | | 0.47 | | 0.59 | | 0.47 | |
| Hold current | A | 0.13 | | 0.12 | | 0.17 | | 0.14 | |
| Closed | W | 2.8 | | 2.9 | | 3.5 | | 3.1 | |
| Operating times, typical | | | | | | | | | |
| • On | ms | <160 | | <140 | | <160 | | <140 | |
| • Off | ms | <35 | | <35 | | <30 | | <30 | |
| Type | | 3RA6 20-□P3., 3RA6250-□P3. □ = A, B, C or D Rated operational current ≤ 12 A | | | | 3RA6120-EP3., 3RA6250-EP3. Rated operational current 32 A | | | |
| Rated control supply voltage | V | 110 AC | 240 AC | 110 DC | 240 DC | 110 AC | 240 AC | 110 DC | 240 DC |
| Inrush peak current | A | 0.24 | 0.40 | 0.17 | 0.29 | 0.24 | 0.40 | 0.17 | 0.29 |
| Hold current | A | 0.06 | 0.08 | 0.03 | 0.02 | 0.06 | 0.07 | 0.04 | 0.03 |
| Closed | W | 3.8 | 6 | 3.1 | 5.1 | 3.7 | 5.2 | 3.4 | 5.8 |
| Operating times, typical | | | | | | | | | |
| • On | ms | <160 | <140 | <150 | <140 | <160 | <140 | <150 | <140 |
| • Off | ms | <50 | <80 | <50 | <70 | <40 | <60 | <40 | <60 |
| Type | | 3RA6400-□B4., 3RA6500-□B4. □ = A, B, C or D Rated operational current ≤ 12A | | | | 3RA6400-EB4., 3RA6500-EB4. Rated operational current 32 A | | | |
| Rated control supply voltage | V | 24 DC | | | | 24 DC | | | |
| Inrush peak current | A | 0.39 | | | | 0.53 | | | |
| Hold current | A | 0.13 | | | | 0.15 | | | |
| Closed | W | 2.9 | | | | 3.4 | | | |
| Operating times, typical ¹⁾ | | | | | | | | | |
| • On | ms | <140 | | | | <140 | | | |
| • Off | ms | <35 | | | | <30 | | | |

¹⁾ Plus IO-Link communication

Load Feeders and Motor Starters for Use in the Control Cabinet

SIRIUS 3RA6 Compact Starters

General data

| Type | | 3RA61 | 3RA62 | 3RA64 | 3RA65 |
|--|---|------------------|---|-------|-----------|
| Size | | S0 | | | |
| Number of poles | | 3 | | | |
| Control circuit | | | | | |
| Rated operational voltage | | | | | |
| • External auxiliary switch block | V | 400/690 | | | |
| • Internal auxiliary switch | V | 400/690 | | | |
| • Short-circuit signaling switch | V | 400 | | | |
| • Overload signaling switch | V | 400 | | | |
| Switching capacity | | | | | |
| • External auxiliary switch block | | | | | |
| | AC-15 | | | | |
| | • Up to $U_e = 230$ V | A | 6 | | |
| | • Up to $U_e = 400$ V | A | 3 | | |
| | • Up to $U_e = 289/500$ V | A | 2 | | |
| | • Up to $U_e = 400/690$ V | A | 1 | | |
| | DC-13 | | | | |
| | • Up to $U_e = 24$ V | A | 6 | | |
| | • Up to $U_e = 60$ V | A | 0.9 | | |
| | • Up to $U_e = 125$ V | A | 0.55 | | |
| | • Up to $U_e = 250$ V | A | 0.27 | | |
| • Internal auxiliary switch | | | | | |
| | AC-15 | | | | |
| | • Up to $U_e = 230$ V | A | 6 | | |
| | • Up to $U_e = 400$ V | A | 3 | | |
| | • Up to $U_e = 289/500$ V | A | 2 | | |
| | • Up to $U_e = 400/690$ V | A | 1 | | |
| | DC-13 | | | | |
| | • Up to $U_e = 24$ V | A | 10 | | |
| | • Up to $U_e = 60$ V | A | 2 | | |
| | • Up to $U_e = 125$ V | A | 1 | | |
| | • Up to $U_e = 250$ V | A | 0.27 | | |
| | • Up to $U_e = 480$ V | A | 0.1 | | |
| • Signaling switches | | | | | |
| | AC-15 | | | | |
| | • Up to $U_e = 230$ V | A | 3 | | |
| | • Up to $U_e = 400$ V | A | 1 | | |
| | DC-13 | | | | |
| | • Up to $U_e = 24$ V | A | 2 | | |
| | • Up to $U_e = 250$ V | A | 0.11 | | |
| External auxiliary switch blocks, internal auxiliary switches | | | | | |
| Endurance in operating cycles | | | | | |
| • Mechanical endurance | | | 10 000 000 | | 3 000 000 |
| • Electrical endurance | | | | | |
| | AC-15, 230 V | | | | |
| | • Up to 6 A | | 200 000 | | |
| | • Up to 3 A | | 500 000 | | |
| | • Up to 1 A | | 2 000 000 | | |
| | • Up to 0.3 A | | 10 000 000 | | |
| | DC-13, 24 V | | | | |
| | • Up to 6 A | | 30 000 | | |
| | • Up to 3 A | | 100 000 | | |
| | • Up to 0.5 A | | 2 000 000 | | |
| | • Up to 0.2 A | | 10 000 000 | | |
| | DC-13, 110 V | | | | |
| | • Up to 1 A | | 40 000 | | |
| | • Up to 0.55 A | | 100 000 | | |
| | • Up to 0.3 A | | 300 000 | | |
| | • Up to 0.1 A | | 2 000 000 | | |
| | • Up to 0.04 A | | 10 000 000 | | |
| | DC-13, 220 V | | | | |
| | • Up to 0.3 A | | 110 000 | | |
| | • Up to 0.1 A | | 650 000 | | |
| | • Up to 0.05 A | | 2 000 000 | | |
| | • Up to 0.018 A | | 10 000 000 | | |
| Contact reliability | At 17 V and 5 mA | Operating cycles | 1 incorrect switching operation per 100 000 000 | | |
| Short-circuit protection | | | | | |
| • Short-circuit current $I_K \leq 1.1$ kA | Fuse links, operational class gG - NEOZED Type 5SE - DIAZED Type 5SB - LV HRC Type 3NA | A | 10 | | |
| • Short-circuit current $I_K < 400$ A | Miniature circuit breaker up to 230 V with C characteristic | A | 10 | | |

Load Feeders and Motor Starters for Use in the Control Cabinet

SIRIUS 3RA6 Compact Starters

General data

| Type | | | 3RA61 | 3RA62 | 3RA64 | 3RA65 |
|---|---|------------------|---|-------|-------|-------|
| Size | | | S0 | | | |
| Number of poles | | | 3 | | | |
| Signaling switches | | | | | | |
| Endurance in operating cycles | | | | | | |
| • Mechanical endurance | | | 20 000 | | | |
| • Electrical endurance AC-15 | At 230 V and 3 A | | 6 050 | | | |
| Contact reliability | At 17 V and 5 mA | Operating cycles | 1 incorrect switching operation per 100 000 000 | | | |
| Short-circuit protection | | | | | | |
| • Short-circuit current $I_K \leq 1.1$ kA | Fuse links operational class gG - NEOZED Type 5SE - DIAZED Type 5SB - LV HRC Type 3NA | A | 6 | | | |
| • Short-circuit current $I_K < 400$ A | Miniature circuit breaker up to 230 V with C characteristic | A | 6 | | | |
| Overload (short-circuit current $I_K \leq 1.1$ kA) | Fuse links operational class gG - NEOZED Type 5SE - DIAZED Type 5SB - LV HRC Type 3NA | A | 4 | | | |

More information

Notes on safety

System networking requires suitable protective measures (including network segmentation for IT security) in order to ensure safe plant operation.

For more information about the subject of Industrial Security, see www.siemens.com/industrialsecurity.

Accessories

Further information

You will find all information on configuring and dimensioning the accessories in the 3RM1 manual:

<https://support.industry.siemens.com/cs/ww/en/view/66295730>

3-phase infeed system (3RM19 3-phase busbar system)

The system permits an easy, time-saving and safe means of feeding two or more 3RM1 motor starters. It can be used only with motor starters with screw terminals in the main circuit.

The maximum summation current must not exceed 25 A. The primary infeed is connected via a 3-phase infeed terminal.

The busbars are available in three lengths, with two, three or five sockets. More than five devices can be connected by clamping the connection tags of a second busbar rotated by 180°.

The 3-phase busbars are finger-safe but empty connection tags must be fitted with covers.

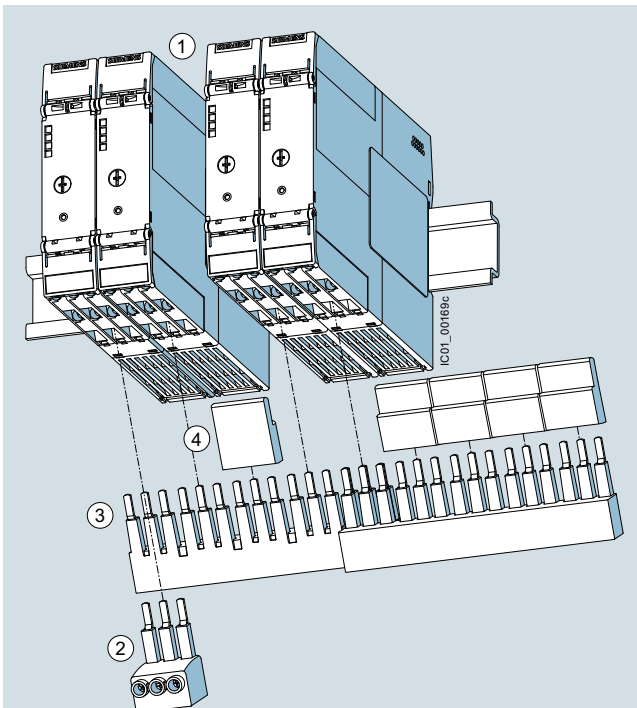

- ① Four 3RM1 motor starters on standard mounting rail with one free slot
- ② 3RM1920-1AA three-phase feeder terminal
- ③ Two 3RM1910-1DA three-phase busbars rotated through 180° for the connection of up to nine motor starters
- ④ Covers for three 3RM1910-6AA connection tags respectively

3RM19 infeed system with three-phase infeed terminal: In the above example, two three-phase busbars (5-pole busbars) rotated through 180° allow up to 9 3RM1 motor starters to be connected. Contact with the unused connection tags in unoccupied positions is prevented safely by the covers.

Device connectors for the control circuit

The device connectors for 3RM1 motor starters (only 24 V DC control supply voltage) reduce the outlay for cabling by looping through the control supply voltage. The device connectors can be snapped onto a standard mounting rail or fixed to a level mounting panel using screws.

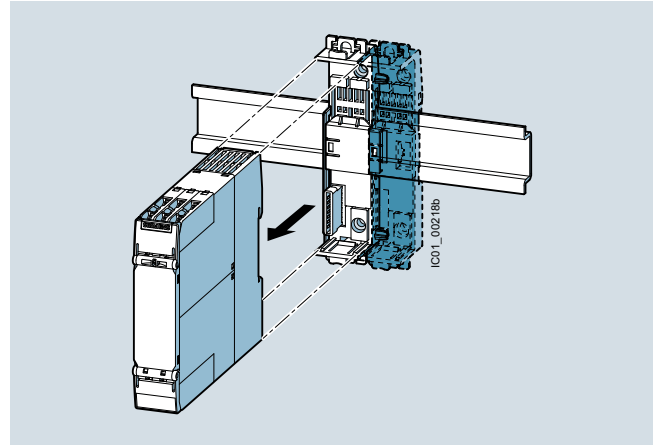

Device connectors with 3RM1 motor starter

Using the device connectors exclusively for feeding in the control supply voltage

By using device connectors, a maximum of five motor starters can be supplied with 24 V DC control supply voltage. This requires the control supply voltage to be applied to the A1 and A2 terminals of only one motor starter.

Device daisy chain connectors can be used for gaps between two motor starters. Device termination connectors terminate a group.

Using the device connectors for safe group shutdown

In combination with the 3RM11 and 3RM13 Failsafe motor starters, the device connector can also be used for safety-related shutdown. For this application, groups of no more than five Failsafe motor starters can be connected using a device connector, and the group must be terminated with a terminating connector. Removing the control voltage supply from the first motor starter will safely shut down the whole group.

Safe group shutdown can be implemented particularly easily in conjunction with 3SK safety relays. In this case, up to five motor starters can be directly connected to 3SK safety relays via the device connector and then safely shut down (see page 11/13).

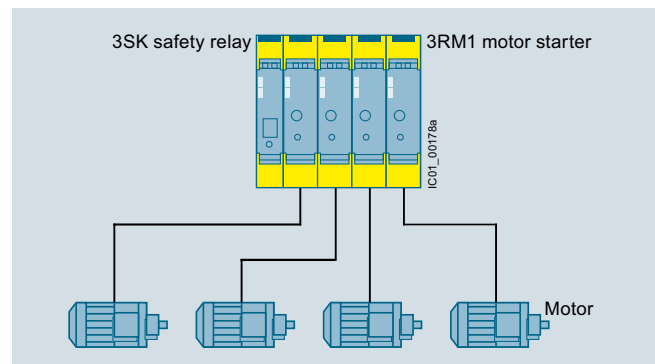

Ideal connection: Combination of four SIRIUS 3RM1 Failsafe motor starters with SIRIUS 3SK1 safety relay