

# U-Line™ Factory Sealed 15 and 20 Amp Plugs and Receptacles

## Explosionproof, Dust-Ignitionproof

Dead-Front Safety Construction – Grounding through Extra Pole and Shell.

### CEC:

Class I, Division 1 and 2 Groups B, C, D  
Class II, Division 1 and 2 Group G – Coal Dust  
Class III  
CSA Type 7BCD, 9G

### Applications

- Locations where receptacles are used with stationary or portable electrically operated devices such as:
  - Lighting systems
  - Conveyors
  - Heaters
  - Motor-generator sets
  - Air conditioners
  - Compressors
  - Pumps
- Locations with damp or corrosive conditions.
- Class I: classified locations where ignitable vapors or gases are present such as:
  - Petrochemical plants
  - Petroleum refineries
  - Paint and chemical plants
- Class II: classified locations such as:
  - Process industries where there are dust hazards from handling such products as flour, grain and starch or any location where ignitable amounts of dust are present or amounts which would adversely affect performance.

### Features

- Intermateable with competitor's plugs of like configurations.
- Factory sealed, external seals not required. Arcing is safely confined to receptacle interior.
- Energized receptacle contacts deeply recessed to reduce danger of accidental touching.
- Unique blade-type, brass contacts exert constant pressure along entire contact surface and provide superior electrical contact.
- Insulators provide superior dielectric and mechanical strength and lowest arc tracking.
- ECP plug fits any standard non-explosionproof receptacle (NEMA 5-15R, 5-20R, or 6-20R) as well as U-Line™ explosionproof receptacles.



### Standard Materials

- Receptacle, cover and mounting box: copperfree (4/10 of 1% max.) aluminum
- ECP plugs: copperfree (4/10 of 1% max.) aluminum housings
- Insulating blocks: glass-filled reinforced polyester

### Standard Finishes

- Receptacles: epoxy powder coat
- Cord connector housings and caps: epoxy powder coat

### CEC Certifications and Compliances

- CSA Standard: C22.2 No. 25, C22.2 No. 30, C22.2 No 42, C22.2 No. 159
- CSA Certified: 038644

### Illustrated Features



CSA Approved when used with Killark® "UGR" Series and Crouse-Hinds® "ENR" Series receptacles. Crouse-Hinds and ENR are registered trademarks of Cooper Crouse-Hinds. Killark and UGR are registered trademarks of Hubbell Incorporated

# U-Line™ Factory Sealed 15 and 20 Amp Plugs and Receptacles

## Explosionproof, Dust-Ignitionproof

Dead-Front Safety Construction – Grounding through Extra Pole and Shell.

### CEC:

Class I, Division 1 and 2 Groups B, C, D  
Class II, Division 1 and 2 Group G – Coal Dust  
Class III  
CSA Type 7BCD, 9G

### Illustrated Features

**Spring door cover** keeps dust out of receptacle when plug is not in use, which may be rotated 180° or completely removed. Stainless steel cover spring-completely enclosed for protection from corrosive environments. Cover may be used with hinge at top (standard) or rotated 180° to put hinge at bottom.

**Factory sealed receptacle/switch interior.** Switch is an integral part of receptacle interior, contained in an aluminum sleeve. Protective xylan coating on inside of sleeve provides smooth "rotating" action of internal switch, which is activated by rotating plug in receptacle. Entire aluminum sleeve is sealed at both ends with neoprene O-rings to protect receptacle/switch interior against moisture.

**ECP Interchanger plug** fits ordinary location receptacles (NEMA 5-20R or 15R and NEMA 6-20R) and explosionproof U-Line™ receptacle as well competitors comparable NEMA blade configured receptacles.

**Solderless lugs**—all terminals are pressure type to facilitate wiring.

**Longer plug housing** for better gripping and easier plug insertion and withdrawal.

**Knock-out in plug** insulator permits "potting" of terminations for positive protection in severe environments.

**A twist of the plug** produces audible "click" to indicate fast make and break of built-in switch contacts. Twisting plug locks it in place—cannot be accidentally pulled out.

**With plug in use,** neoprene gasket in throat of receptacle "seals" around plug keeping out dirt, water, dust and other foreign matter.

**With plug not in use,** spring-loaded door seats against neoprene gasket to seal receptacle from corrosive atmospheres.



**For safety...** Ordinary location plug will NOT activate explosionproof U-Line™ receptacle.

**Plug mechanical cable clamps** on the plug prevent strain on cables and meet or exceed UL 150 lb. strain relief pull-out test for classified locations.



**Special neoprene watertight plug bushing** accommodates flexible cord ranging from .538" to .639" in diameter.



# U-Line™ Factory Sealed 15 and 20 Amp Plugs and Receptacles



## Explosionproof, Dust-Ignitionproof

Dead-Front Safety Construction – Grounding through Extra Pole and Shell.



**CEC:**

Class I, Division 1 and 2 Groups B, C, D  
 Class II, Division 1 and 2 Group G – Coal Dust  
 Class III  
 CSA Type 7BCD, 9G

### Receptacle and Cover Assembly

Description	Catalog Number	
	125 Vac, 1 HP 	250 Vac, 2 HP 
 20 Amp	ECSK-2023	ECSK-20232

### Mounting Box – Complete with 1 Close-Up Plug

	Hub Size	Catalog Number
<b>Single Gang</b>		
	3/4"	ECS175
	1"	ECS110
<b>Two Gang</b>		
	3/4"	ECS275
	1"	ECS210

### Dimensions in Millimeters (Inches)

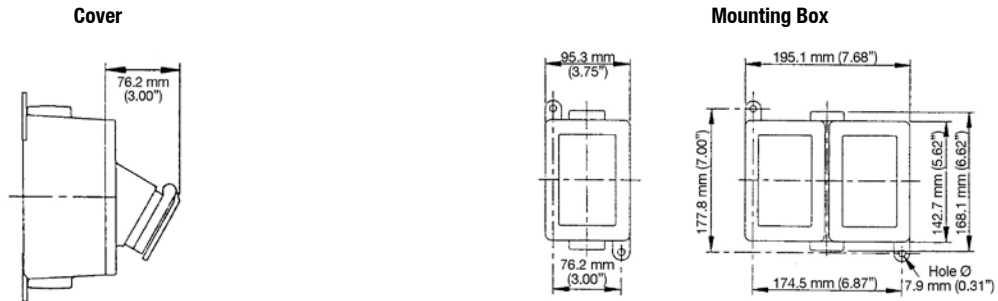

Appleton®

PLUGS AND RECEPTACLES: NEC/CEC HAZARDOUS LOCATION