

FREE-STAND SINGLE AND DUAL ACCESS WITH 3-POINT LATCHES, TYPE 4X



of 19-in. rack-mounting accessories makes these enclosures ideal for providing rugged protection for sensitive rack-mounted components in harsh industrial environments. These enclosures are used extensively in automotive, pulp and paper, wood products, textile and similar industries.

Four styles are available to provide maximum flexibility:

1. One-Door Single-Access Enclosures (single door on front)
2. One-Door Dual-Access Enclosures (single door on front and rear)
3. Two-Door Single-Access Enclosures (doors close on a removeable centerpost)
4. Two-Door Dual-Access Enclosures (doors close on a removeable centerpost on front and rear)

SPECIFICATIONS

- 12 gauge Type 304 stainless steel
- Seams continuously welded and ground smooth; no holes or knockouts
- Two-door enclosures provided with a removeable centerpost for easy panel installation
- Heavy-duty lifting eyes are Type 316L stainless steel
- Heavy-duty three-point latching mechanism operated by Type 316L stainless steel POWERGLIDE padlocking handle
- Seamless foam-in-place gasket assures a water-tight and dust-tight seal
- Body flange trough collar excludes liquids and contaminants
- Heavy-gauge continuous hinges support each door
- High-impact thermoplastic data pocket provided with each enclosure
- Mounting channels welded horizontally to interior body sides at top, bottom and center
- Optional panels and rack mounting angles can be mounted anywhere along channels
- Bonding provision on door; grounding stud on body
- Accessory mounting channel provided in enclosure top

FINISH

Enclosures are unpainted. Cover, sides, top and bottom have smooth #4 brushed finish. Optional steel panels, swing-out panels, side-mounted panels, rack-mounting frames, heavy-duty panel supports and center panel supports are white. Optional full, half and side-mounted conductive panels are available.

ACCESSORIES

See also Accessories.

Caster Kit

Clamping Nut Package

Floor Stand Kit, Stainless Steel

Center Panel Supports

Panels for Free-Stand Type 4, 4X and 12 Single- and Dual-Access

One-Door Enclosures with Mounting Channel

Panels for Free-Stand Type 4, 4X and 12 Single- and Dual-Access

Two-Door Enclosures with Mounting Channel

MODIFICATION AND CUSTOMIZATION

Hoffman excels at modifying and customizing products to your specifications. Contact your local Hoffman sales office or distributor for complete information.

BULLETIN: A30S4

INDUSTRY STANDARDS

UL 508A Listed; Type 3R, 4, 4X, 12; File No. E61997
cUL Listed per CSA C22.2 No 94; Type 3R, 4, 4X, 12; File No. E61997

NEMA/EEMAC Type 3, 3R, 4, 4X, 12, 13

E.I.A. RS-310-D

IEC 60529, IP66

Meets NEMA Type 3RX requirements

APPLICATION

Designed to house systems incorporating large components or complex mounting configurations. Three-point latching and sealing provide industry-leading protection from dust, dirt, oil and water. These enclosures are used in machine tool applications for housing motor starters, drives, contactors and PLCs, as well as a wide variety of other electrical and electronic equipment. The addition

Standard Product **One-Door Single-Access**

Catalog Number	AxBxC in./mm	F in./mm	G in./mm
A602418SSFSN4	60.06 x 24.06 x 18.06 1526 x 611 x 459	32.03 814	23.12 587
A722418SSFSN4	72.06 x 24.06 x 18.06 1830 x 611 x 459	38.03 966	29.12 740
A723018SSFSN4	72.06 x 30.06 x 18.06 1830 x 764 x 459	38.03 966	29.12 740
A723618SSFSN4	72.06 x 36.06 x 18.06 1830 x 916 x 459	38.03 966	29.12 740
A902420SSFSN4	90.06 x 24.06 x 20.06 2288 x 611 x 510	47.03 1195	38.12 968
A903620SSFSN4	90.06 x 36.06 x 20.06 2288 x 916 x 510	47.03 1195	38.12 968
A603624SSFSN4	60.06 x 36.06 x 24.06 1526 x 916 x 611	32.03 814	23.12 587
A722424SSFSN4	72.06 x 24.06 x 24.06 1830 x 611 x 611	38.03 966	29.12 740
A723024SSFSN4	72.06 x 30.06 x 24.06 1830 x 764 x 611	38.03 966	29.12 740
A723624SSFSN4	72.06 x 36.06 x 24.06 1830 x 916 x 611	38.03 966	29.12 740
A903624SSFSN4	90.06 x 36.06 x 24.06 2288 x 916 x 611	47.03 1195	38.12 968
A723630SSFSN4	72.06 x 36.06 x 30.06 1830 x 916 x 764	38.03 966	29.12 740
A723636SSFSN4	72.06 x 36.06 x 36.06 1830 x 916 x 916	38.03 966	29.12 740
A903636SSFSN4	90.06 x 36.06 x 36.06 2288 x 916 x 916	47.03 1195	38.12 968

Purchase panels and accessories separately.

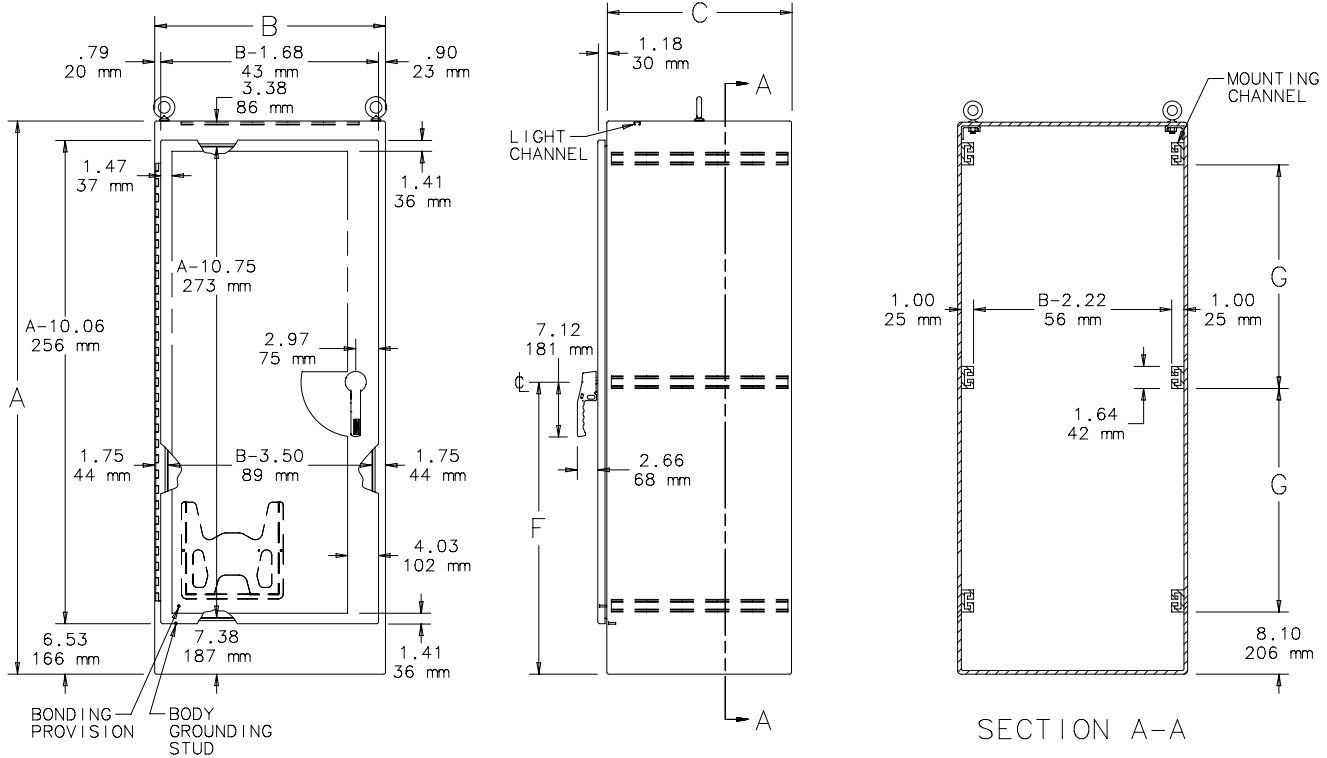

87576784

- NOTES:
1. Four lifting eyes are furnished if C=30.06 (764mm) or more.
 2. See General Accessories chapter for section views A-A and B-B showing accessories.
 3. Removable 12.00 x 12.00 (305mm x 305mm) data pocket.