

## Ground Rod Accessories and Ground Plates

For joining non-threaded, copper-bonded steel ground rods.

### Threadless Couplings and Driving Cap

- Couplings manufactured of high-strength, corrosion-resistant copper alloy
- High-strength hardened steel driving cap prevents “mushrooming” of ground rod while driving to ensure proper fit of coupling



CAT. NO.	DESCRIPTION	DIMENSIONS (IN.)	
		LENGTH	DIAMETER
50LCNT*	1/2" L Threadless Coupling	3.0	.78
60CNT2*	5/8" Threadless Coupling	2.5	.69
70CNT*	3/4" Threadless Coupling	3.0	.97
60DSNT	5/8" Threadless Driving Cap	4.0	.88

\* UL® Listed.

As efficient as two 10-ft. x 5/8" ground rods.

### Galvanized Ground Plates

- 1/4" thick, hot-dipped galvanized
- Must be buried at least 600mm (24") below finish grade level, according to CEC Rule 10-702

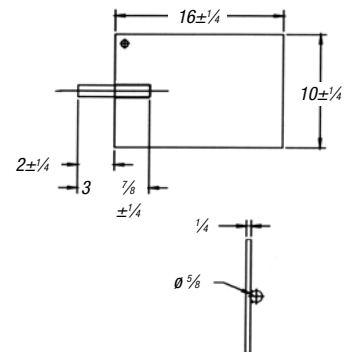

CAT. NO.	DESCRIPTION	CONDUCTOR RANGE
1016TB	Galvanized Ground Plates	#8 Sol. to 1/0 Str.
1016BTB	Galvanized Ground Plates with JAB58H Connector	#8 Sol. to 1/0 Str.