



Premier™ Series

Thermoplastic Combination Unit

Project/Location: _____

Contractor: _____

Date: _____

Prepared by: _____

Features

The Premier™ Series of combination units (unit equipment with an exit sign) are designed with aesthetics, ease of installation and performance in mind.

- One-pack combination of battery unit and exit sign, a compact and contemporary design
- Durable injection-molded thermoplastic housing with push-to-snap design
- Available in single or double face configurations both with means for ceiling mounting
- Comes with the Emergi-Light Premier™ E2Z canopy and field-selectable snap chevrons for quick and easy installation
- Exit sign module illuminated by long-life ALINGAP red LEDs
- Two MR16 halogen lamps, shielded by a clear polycarbonate cover
- Optional MR16 LED lamps with life expectancy 50,000+ hours
- Sealed, maintenance-free, Lead-Calcium or Nickel-Metal-Hydride batteries
- Remote load capacity, up to 92Watts
- Dual voltage input: 120/347 VAC or 120/277 VAC.
- Optional advanced diagnostic circuitry, flasher/buzzer, fire alarm activated flasher
- Optional vandal resistant shield with tamper proof screws
- Certified CSA C22.2 No141
- Certified CSA C860-01



Typical Specification

Supply and install the Premier™ Series combination of unit equipment and exit sign. The standard equipment shall operate with a dual voltage input of 120/347VAC. The unit shall be suitable for wall or ceiling mount. The unit frame and face plates shall be made of injection-molded durable high-impact thermoplastic and come standard with snap in/out chevrons. No screws are necessary to hold the faceplate or backplate to the housing. The one piece thermoplastic frame is molded in white (optional black). The faceplates shall feature a uniformly illuminated legend. The light source shall be light emitting diodes (LED) and shall provide illumination in normal and emergency operation and shall be mounted inside the combination housing. Red LED technology shall be ALINGAP. An LED-sensitive diffuser shall be mounted behind the legend to provide the 6" high by 3/4" stroke letters with even illumination. The unit shall be equipped with two emergency heads with tool-less adjustable swivels (lamps of 12W or less) and long-life MR-16 halogen lamps of ___ V and ___ W. Each lamp shall be protected by a snap-on, shock-absorbent, transparent polycarbonate cover.

The unit shall be equipped with a test switch and a green pilot light, located on the face plate above the EXIT legend. The battery charger shall be driven by a micro-controller. All electronic circuitry (charger, LED driver, LED's) shall be installed on a single printed circuit board PCB. The unit equipped with self-testing / self-diagnostic features shall automatically self test for one minute every 30 days, 10 minutes in the 6th month and 30 minutes annually. When a fault is detected, the bi-color pilot-light shall turn from green to red and shall flash, identifying the source of the failure: battery, charger circuitry, lamp load, LED strip. The exit sign module shall be CSA-C860 approved.

The combo unit shall be Emergi-Lite model: _____.

Dimensions

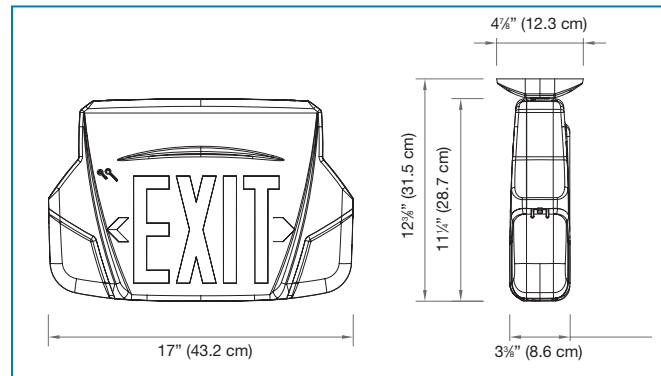

Power Consumption and Unit Rating

Model	AC Specs	Wattage Capacity					
		30min	1h00	1h30	2h00	4h00	
Exit Sign module	120 / 347Vac	Less than 2W	-	-	-	-	-
L2		0.11/0.04 Amp	20	15	12	8	-
L5		0.22/0.08 Amp	50	30	24	16	8
L5A			50	30	24	16	8
H5A			50	36	24	18	9
H10A			100	72	48	36	18

Ordering Information

Series	Colour	Voltage	Powerpack	Legend	Options	Number of Heads	Head Style and Wattage	
PRE1 = single face ceiling or wall mount PRE2 = double face ceiling mount PRE1N = single face wall mount (less canopy) PREU = universal, 2 faces backplate and canopy	W = factory white B = black	3 = 120/347Vac 2 = 120/277Vac	-L2 = 6V-20W Lead cal -L5 = 6V-50W Lead cal -L5A = 12V-50W Lead cal -H5A = 12v-50W Nimh -H10A = 12V-100W Nimh	Blank = red letters G = green letters	Blank = no options D3 = 15 min. time delay U = auto-diagnostics UN = auto-diagnostics non-audible FZ = flasher buzzer FA = fire alarm activated flasher FBF = flasher buzzer +fire alarm activated flasher 990.0119-E = tamper proof bit* *One bit per order. Sold separately.	VRTP = polycarbonate shield with tamper proof screws TP = tamper proof screws BA = brushed aluminum exit stencil FL = flasher	/0 = no heads /2 = two heads	MI = 6V 6 watts MR16 MJ = 6V10W MR16 MO = 12V10W MR16 MK = 12V12W MR16 LG = 12V4W LED MR16

EXAMPLE: PRE1W3-L2/2MI