

Type S611, Soft Starter



Contents

Description	Page
Type S611, Soft Starters	
Features and Benefits	V6-T1-44
Operation.	V6-T1-47
Catalog Number Selection	V6-T1-50
Product Selection	V6-T1-51
Accessories	V6-T1-52
Replacement Parts	V6-T1-53
Technical Data and Specifications	V6-T1-54
Dimensions	V6-T1-57
Type S801+, Soft Starters	V6-T1-59
Type S811+, Soft Starters with DIM	V6-T1-75

Type S611, Soft Starters

Product Description

Eaton revolutionized the reduced voltage control marketplace with its advanced feature set and user-friendly user interface module to enhance system performance and reduce commissioning times. The S611 adds enhanced functionality with network communications, metering, monitoring and diagnostics capabilities.

The Eaton line of S611 reduced voltage soft starters is multi-functional, easy to install and easy to program. Designed to control the acceleration and deceleration of three-phase motors up to 600 V, the line is available from 26 amps through 414 amps.

The S611 is designed to be a complete package combining the SCRs, bypass contactor and overload in one unit.

Application Description

Designed to control the acceleration and deceleration of three-phase motors, the S611 soft starter uses Silicon Controlled Rectifiers (SCRs) to control the voltage to soft start and soft stop the motor. After the motor is started, internal run bypass contactors close, resulting in the motor running directly across-the-line. The built-in solid-state overload protects the motor from overload conditions with sophisticated algorithms that model true motor heating, resulting in better motor protection and fewer nuisance trips. Advanced protective and diagnostic features reduce downtime.

A voltage ramp start or current limit start is available. Kick start is available in either starting mode. The soft stop option allows for a ramp stop time that is longer than the coast to stop time. The pump control option provides a smooth transition for starting and stopping a motor and eliminating the “water-hammer” effect that can damage pipes, valves and pumps.

The S611 offers an impressive array of advanced protective features. Not only are the protective features selectable, but many offer variable settings allowing the user to fine tune the soft starter to meet specific system requirements.

The S611 has an easy to use User Interface Module (UI) that allows the user to configure the device and to read system parameters and values. The UI includes an LED display and keypad to scroll through the various parameters. The UI allows the user to modify control parameters, enable or disable protections, set communication variables, monitor system values such as line voltages and currents, and access the fault queue.

User Interface Module (UI)

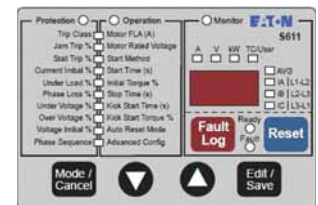

The UI can be removed from the S611 and remote mounted. Kits are available to door mount the UI, enabling users to safely configure, commission, monitor and troubleshoot the system at the electrical panel without opening the enclosure door. This will help eliminate the possibility of an arc flash incident.

Standards and Certifications

- IEC 60947-4-2
- UL listed
- CSA certified (3211 06)



1

Edge and Level Sensing Control

Edge or Level Sensing is selected with the Start Control parameter in the Advanced Configuration Menu. Factory default is Level Sensing.

Edge Sensing

Edge sensing requires 120 Vac power be momentarily applied to the Start terminal (with the Permissive terminal 120 Vac) to initiate a start under all conditions. After a stop or fault occurs, the 120 Vac must be reapplied to the start terminal before another start can occur. This control configuration should be used when restarting of the motor after a fault or stop must be supervised manually or as a part of a control scheme. The cycling of 120 Vac power to the Permissive terminal before starting is required regardless of the position of the auto reset parameter.

Level Sensing

Level sensing will enable a motor to restart after a fault is cleared without cycling 120 V AC to the Permissive terminal as long as:

- Permissive terminal is supplied with 120 Vac
- The auto reset parameter is set to enabled
- All faults have cleared or have been reset

This control configuration should be used where it is desirable to restart a motor after a fault without additional manual or automatic control. An example of this condition would be on a remote pumping station where it is desirable to automatically restart a pump after a power outage without operator intervention.

Note: If the auto reset feature is used, CAUTION must be exercised to assure that any restart occurs in a safe manner.

Catalog Number Selection

S611 Soft Starters

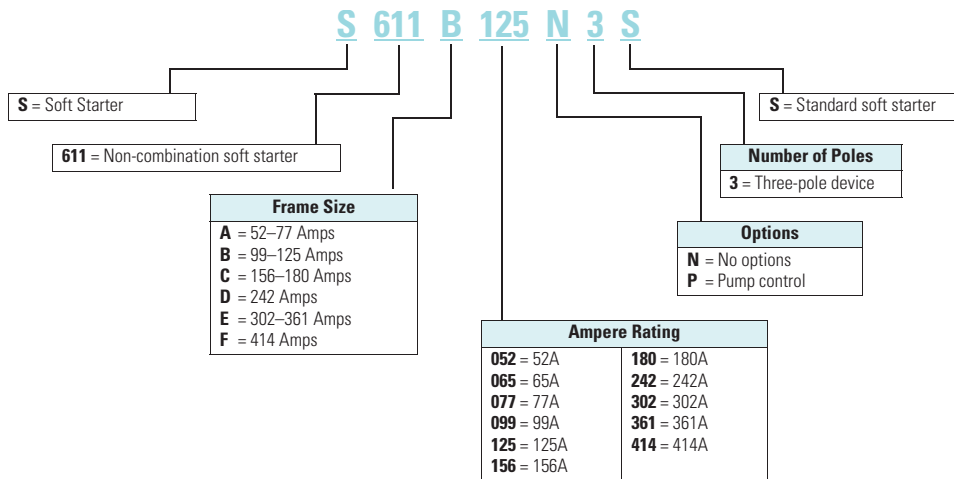

Product Selection

Motor applications and customer needs come in many different varieties. With the standard and severe duty rating tables, we have attempted to provide

guidelines on what the soft starter is capable of. If the application falls under these categories, you can use these charts. For other applications, or when a question arises,

consult with your local Eaton Representative or call the Eaton Technical Resource Center.

Pump Control Option

For pump control option, change the **8th** digit in the Catalog Number to **P**, as in S611XXX**P**3S.

Horsepower Ratings

Note: Always refer to motor plate FLA and ensure that the motor plate FLA is equal to or lower than the maximum current value in the tables.

S611



Standard Duty—300% Current for 15 Seconds, 115% Continuous

Rated Current (Amps)	Horsepower Rating				Catalog Number
	208V	240 V	480 V	600 V	
52	15	15	40	50	S611A052N3S
65	20	20	50	60	S611A065N3S
77	25	25	60	75	S611A077N3S
99	30	30	75	100	S611B099N3S
125	40	40	100	125	S611B125N3S
156	50	60	125	150	S611C156N3S
180	60	60	150	150	S611C180N3S
242	75	75	200	250	S611D242N3S
302	100	100	250	300	S611E302N3S
361	125	150	300	350	S611E361N3S
414	150	150	350	450	S611F414N3S

Standard Duty Plus—350% FLA for 30 Seconds, 115% Continuous

Rated Current (Amps)	Horsepower Rating				Catalog Number
	208V	240 V	480 V	600 V	
52	15	15	40	50	S611A052N3S
65	20	20	50	60	S611A065N3S
71	20	25	60	75	S611A077N3S
99	30	30	75	100	S611B099N3S
119	40	40	100	125	S611B125N3S
156	50	60	125	150	S611C156N3S
180	60	60	150	150	S611C180N3S
242	75	75	200	250	S611D242N3S
302	100	100	250	300	S611E302N3S
361	125	150	300	350	S611E361N3S
407	150	150	350	400	S611F414N3S