

Fusible Disconnect switches



Fusible disconnect switches 30A – 1200A, 600VAC



ABB PowerLine includes seven different amperage sizes from 30A to 1200A. All ABB fusible switches are designed to meet customer requirements in terms of high interrupting capacity and long electrical life while occupying little more panel space than the appropriate fuses. The basic construction provides flexibility and high performance in an extremely compact size. ABB PowerLine switches are a perfect choice to withstand the heat and humidity of the tropics, the extreme cold of the arctic and any rugged industrial environment you may have.

International acceptance

ABB fusible switches are available with a wide range of fuse clip options:

UL	USA	CSA	Canada
DIN	Europe	BS	United Kingdom
NFC	France	Ultra-rapid	

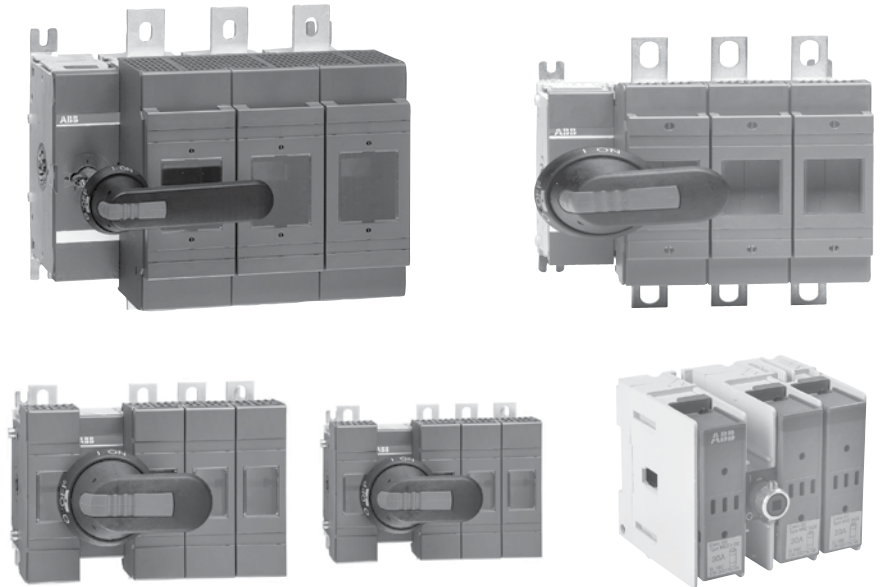
As well as the corresponding approvals: UL listed, CSA approved, IEC rated, CE marked, and most other international standards.

UL98 (CSA 22.2 No.4) – UL File # E101914, CSA File #LR58077

For 30A – 1200A switches, OH_ pistol grip handles

Suitable for use as motor disconnects or industrial control panel disconnects on service entrance equipment, panelboards, switchboards, industrial control equipment, motor control centers, etc. and are horsepower rated and ampere rated.

IEC

Tested in accordance to IEC 947-1 and 3, IEC 664, IEC 269, and IEC 204

CE

Compliance with the European Machine Directive IEC 204 (EN 60204)

Selection guide

OS30FACC12 – OS1200L03

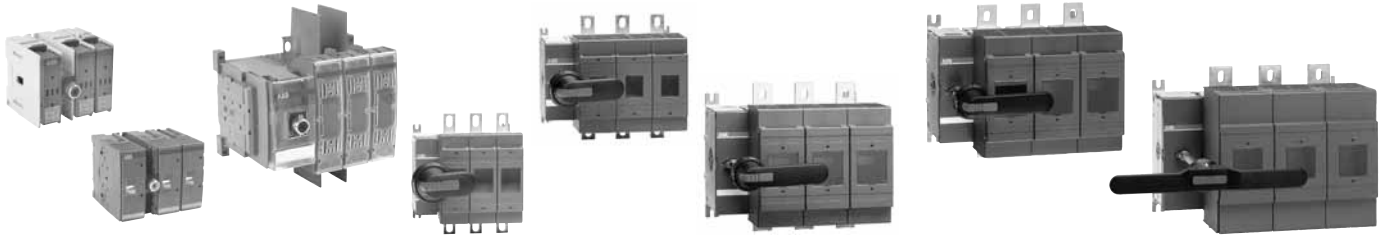

OS30FA_12 OS60J12 OS100J03 OS200J03 OS400J03 OS600J03 OS800L3 OS1200L03

Catalog number 3 pole			OS30FACC12	OS30FAJ12	OS60GJ12	OS100GJ03	OS200J03	OS400J03	OS600J03	OS800L3	OS1200L03	
General purpose amp rating			A	30	30	60	100	200	400	600	800	1200
Approvals ①			2 pole 3 pole 4 pole	N/A UL98 & IEC UL98 & IEC	N/A UL98 & IEC UL98 & IEC	N/A UL98 & IEC UL98 & IEC	UL98 & IEC UL98 & IEC UL98 & IEC	UL98 & IEC UL98 & IEC UL98 & IEC	UL98 & IEC UL98 & IEC UL98 & IEC	UL98 & IEC UL98 & IEC UL98 & IEC	UL98 & IEC UL98 & IEC IEC	
Technical ratings (UL, CSA)												
Max operating voltage			V	600	600	600	600	600	600	600	600	600
Max horsepower rating												
Three phase												
240V			HP	7.5	7.5	15	30	60	125	200	250	—
480V			HP	15	15	30	60	125	250	400	500	—
600V			HP	20	20	50	75	150	350	500	600	—
Single phase												
120V			HP	2	2	—	—	—	—	—	—	—
240V			HP	3	3	—	—	—	—	—	—	—
UL fuse class				CC	J	J	J	J	J	J	L	L
Technical ratings (IEC)												
Rated insulation and operational voltage. AC20 and DC20			V	1000	1000	1000	1000	1000	1000	1000	1000	1000
Rated thermal current, I _{th}												
AC 20/DC 20 open			A	32	32	63	160	200	400	630	800	1250
AC 20/DC 20 enclosed			A	32	32	63	160	200	400	600	720	1250
AC 21A ≤500V			A	32	32	63	160	200	400	630	800	1250
AC 21A ≤690V			A	32	32	63	160	200	400	630	800	1250
Rated operational power AC23												
400/415V			kW	14/15	14/15	30	80/90	110	220/230	355	350/380	560
690V			kW	25	25	60	132	200	400	560	600	1000
Physical characteristics												
Weight												
3 pole switch			lb	1.54	1.54	2.86	3.30	5.9	12.56	28.66	37.44	63.93
4 pole			lb	1.98	1.98	3.52	3.96	7.5	15.21	37.48	46.26	—
Dimension												
3 pole			H in	3.66	3.60	3.94	5.67	6.5	9.29	12.03	12.03	16.7
			W in	4.15	4.15	5.63	7.07	7.1	10.04	13.86	13.86	16.42
			D in	4.10	4.10	5.04	5.10	5.2	6.93	9.18	9.18	11.62
Accessories												
Double break contacts				S	S	S	S	S	S	S	S	S
Fuse cover				S	S	S	S	S	S	S	S	S
Terminal lug kit				Integral	Integral	Integral	OZXA-24	OZXA-200	OZXA-400	OZXA-800	OZXA-1200	OZXA-1200
Terminal shroud				Not required	Not required	Not required	•	•	•	•	•	•
Auxiliary contact				•	•	•	•	•	•	•	•	•
Shaft/handle diameter				6mm .24 x .24"	6mm .24 x .24"	6mm .24 x .24"	6mm .24 x .24"	6mm .24 x .24"	12mm .47 x .47"	12mm .47 x .47"	12mm .47 x .47"	12mm .47 x .47"
Handle UL/NEMA type												
Type 1, 3R, 12				•	•	•	•	•	•	•	•	•
Type 1, 3R, 4, 4X, 12				•	•	•	•	•	•	•	•	•
Recommended pistol handle length				45 - 65mm	45 - 65mm	45 - 65mm	45 - 65mm	65 - 80mm	125 - 175mm	125 - 175mm	125 - 175mm	125 - 175mm
Maximum recommended shaft length				290mm	290mm	290mm	290mm	290mm	595mm	595mm	595mm	595mm
Electrical interlock				—	—	—	—	—	•	•	•	•

S = Standard
• = Available
— = Not available

① UL listed switches are also CSA approved.

Selection information

Disconnect
switches
Fusible

Standard part number designation ①

Fusible OS Switches (30A)

OS 30 F A J 22 F

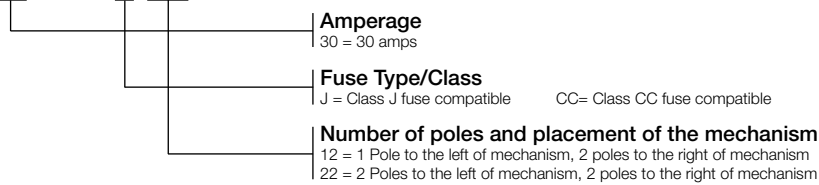

Fusible OS Switches (60 to 100A)

OS 100G J 03

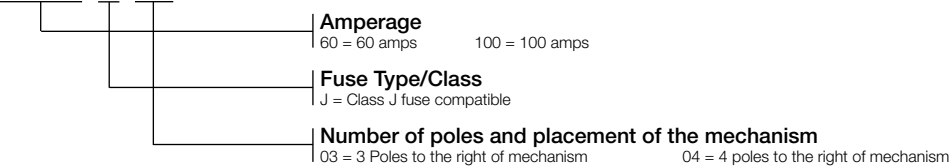

Fusible OS Switches (200A and above)

OS 200 J 04 F

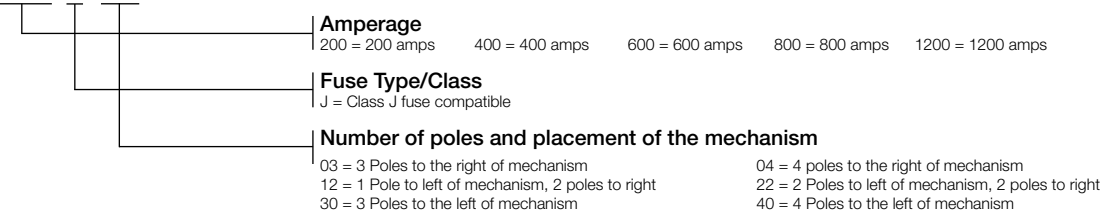

Pistol Handles

O H B 65 J 6 E011



① Part designation keys are provided for reference only. Not all variations or configurations are available.

Base & DIN rail mounted 30 – 1200A

For a complete assembly, please select one of each:

- 1 switch (page 19.22)
- 1 handle (page 19.30)
- 1 shaft (page 19.32)
- 1 terminal lug kit (page 19.34)

NOTE: For additional accessories, see pages 19.29 - 19.42.

(Only required for 100A & above.)

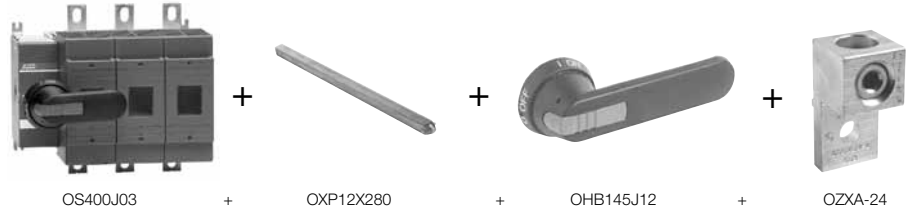

	UL general purpose amp rating	UL Fuse Type 600V	2 Pole	3 Pole	4 Pole
			Catalog number	Catalog number	Catalog number
UL 98	30	J CC ①	— —	OS30FAJ12 OS30FACC12	OS30FAJ22F OS30FACC22F
	60	J	—	OS60GJ12 ② OS60GJ03	OS60GJ22F
	100	J	—	OS100GJ12 ② OS100GJ03 ②	OS100GJ04F
	200	J	OS200J02	OS200J03 OS200J30 OS200J12	OS200J04F OS200J13F OS200J22F
	400	J	OS400J02	OS400J03 OS400J30 OS400J12	OS400J04F
	600	J	OS600J02	OS600J03 OS600J30 OS600J12	OS600J04F
	800	L	OS800L02	OS800L03	OS800L04F
	1200	L	OS1200L02	OS1200L03	OS1200L04F

① Rejection style fuses only.

② Din Rail Mountable: 60A & 100A requires Din Rail Adapter OSGZD1

Technical data

OS30FA_12 – OS1200L03

IEC

IEC

Catalog number	3 pole	OS30FA_12	OS60GJ12	OS100GJ03	OS200J03	OS400J03	OS600J03	OS800L03	OS1200L03	
Technical ratings	-40° to 40°C									
Rated insulation voltage										
Pollution degree 3 ⑥	V	1000	1000	1000	1000	1000	1000	1000	1000	
Dielectric strength 50Hz/60Hz, 1 min	kV	10	10	10	10	10	10	10	10	
Rated impulse withstand voltage	kV	12	12	12	12	12	12	12	12	
Rated thermal current, I _{th} /max. fuse power dissipation ①										
AC 20/DC 20 open ②	A/W	32/3.5	63/7.5	160/12	200/17	400/45	630/60	800/65	1250/110	
40°C enclosed	A/W	32/3.5	63/7.5	160/12	200/15	400/30	570/50	720/55	1000/85	
Enclosed with solid links	A/W	32	–	–	–	–	–	–	–	
with minimum cable cross section Cu	mm ²	6	16	70	95	240	2 x 185	2 x 240	1250/2 x 400	
Rated operational voltage AC 20 and DC 20V		1000	1000	1000	1000	1000	1000	1000	1000	
AC Rated operational currents										
AC 21A	≤500V	A	32	63	160	200	400	630	800	1250 Cat. B
	≤690V	A	32	63	160	200	400	630	800	1250 Cat. B
AC 22A	≤500V	A	32	63	160	200	400	630	800	1250 Cat. B
	≤690V	A	32	63	160	200	400	630	800	1250 Cat. B
AC 23A	≤500V	A	32	63 ③	160 ③	200	400	630	800	1000 Cat. B
	≤690V	A	32	63 ③	160 ③	200	400	630	800	1000 Cat. B
DC Rated operational currents/poles in series										
DC21A	48V	A	32/2 ③	63/2	160/2	200/1	400/2	630/1 CAT. B	800/1 CAT. B	–
	110V	A	32/2	63/2	125/2	200/1	400/2	630/1 CAT. B	800/1 CAT. B	–
	220V	A	32/2	63/2	125/2	200/1	400/2	630/1 CAT. B	800/1 CAT. B	–
	440V	A	32/4	50/4	125/4	200/2	400/3 CAT. B	630/2 CAT. B	800/2 CAT. B	–
	750V	A	–	④	④	180/4	400/4 CAT. B	630/4 CAT. B	720/4 CAT. B	–
	880V	A	–	④	④	180/4	–	630/4 CAT. B	720/4 CAT. B	–
DC22A	48V	A	32/2 ③	63/2	160/2	200/1	400/2	–	800/1 CAT. B	–
	110V	A	32/2	63/2	125/2	200/1	400/2	–	800/1 CAT. B	–
	220V	A	32/2	63/2	125/2	200/1	400/2	–	800/1 CAT. B	–
	440V	A	32/4	–	–	200/2	400/3 CAT. B	–	800/2 CAT. B	–
	750V	A	–	④	④	180/4	400/4 CAT. B	–	800/4 CAT. B	–
	880V	A	–	④	④	180/4	–	–	800/4 CAT. B	–
DC23A	48V	A	32/2 ③	63/2	160/2	200/1	400/2	–	800/1 CAT. B	–
	110V	A	32/2	63/2	125/2	200/1	400/2	–	800/1 CAT. B	–
	220V	A	32/2	63/2	125/2	200/1	400/2	–	800/1 CAT. B	–
	440V	A	32/4	–	–	200/2	400/3 CAT. B	–	800/2 CAT. B	–
	750V	A	–	–	–	180/4	400/4 CAT. B	–	720/4 CAT. B	–
	880V	A	–	–	–	180/4	–	–	720/4 CAT. B	–
Rated operational power	AC23A									
230V	kW	7.5	18.5	45	60	132	200	250	315	
400V	kW	15	30	75	110	220	355	450	560	
415V	kW	15	30	75	110	230	355	450	560	
500V	kW	18.5	37	90	132	280	450	560	710	
690V	kW	22	55	132	200	400	630	710	1000	

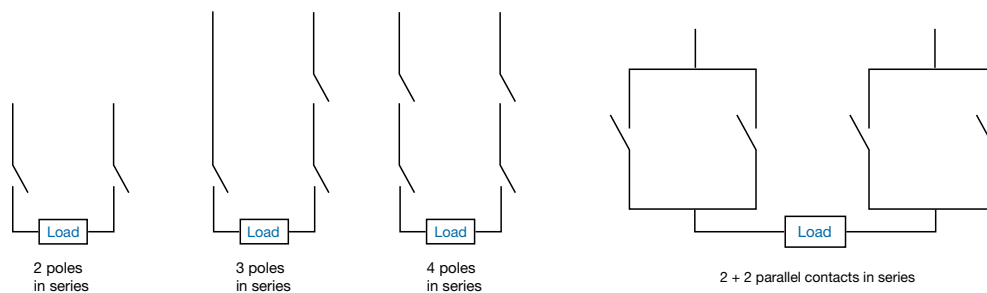

① Ambient temperature 60°C: derating 20 percent. Mounting on ceiling: derating 10 percent. Mounting on wall, horizontal fuses: derating 8 percent.
 ② The ambient air temperature does not exceed +40°C and its average over a period of 24h does not exceed +35°C according to IEC 947.
 ③ For 30A switches, use 2 + 2 parallel contacts in series.
 ④ Available on request.
 ⑤ IEC 947-3, utilization category B, infrequent operation.
 ⑥ Pollution degree 3: Conductive pollution occurs, or dry, non-conductive pollution occurs, which becomes conductive due to condensation.

Technical data

OS30FA_12 – OS1200L03

IEC

Disconnect
switches
Technical
data

IEC

Catalog number	3 pole	OS30FA_12	OS60GJ12	OS100GJ03	OS200J03	OS400J03	OS600J03	OS800L03	OS1200L03
Rated breaking capacity									
in category AC-23A	500V A	256	504	1280	1600	3200	5760	5760	8000
	690V A	256	504	1280	1600	3200	5760	5760	8000
Rated breaking capacity/poles in series									
in category DC-23	<220V A	128/2	252/2	640/2	—	—	—	—	—
	440V A	128/4	—	—	—	—	—	—	—
	500 – 750V A	—	—	—	—	—	—	—	—
	1000V A	—	—	—	—	—	—	—	—
Rated conditional short-circuit current r.m.s. ③									
	80 kA, 415V kA	9	13.5	22	35	40	75	75	89
	100 kA, 500 V kA	8	12.5	22	37.5	40	75	75	105
	50 kA, 690 V kA	7	9.5	15	—	—	—	—	—
	Rated short time withstand current, 1s. kA	1	2.5	5	8	14	18	18	40
Rated capacitor power									
The capacitor rating of the fusible disconnect switch is limited by the fuse link									
	400 V kVar	15	30	60	90	180	250	310	440
	415V kVar	15	32	65	100	200	270	340	460
	690V kVar	25	50	100	160	325	450	550	750
Power loss/pole									
with rated current, without fuse	W	2	4	9	8	30	46	75	75
Mechanical endurance	operations	20,000	20,000	20,000	20,000	16,000	10,000	10,000	6000
Physical characteristics									
Weight	3 pole kg	0.7	1.1	1.5	2.6	5.7	11.5	11.5	29.00
	4 pole kg	0.9	1.3	1.8	—	—	—	—	—
Dimension	3 pole H mm	93	100	144	198.5	236	306	282	424.18
	W mm	106	143	179	181.5	255	343	376	417.07
	D mm	104	120	129	132	176	233	233	295.14
Shaft size square	mm	6 x 6	6 x 6	6 x 6	6 x 6	12 x 12	12 x 12	12 x 12	12 x 12
Terminals									
Built-in terminal size	mm ²	0.5 – 10	2.5 – 25	—	—	—	—	—	—
Terminal bolt size, metric thread	—	—	—	M8 x 25	M8 x 25	M10 x 30	M12 x 40	M12 x 40	M12 x 40
diameter x length	mm	—	—	15-22	15 – 22	30 – 44	50 – 75	50 – 75	50 – 75
Terminal bolt tightening torque	Nm	2	3.5	15-22	15 – 22	20	M10:30 M12:40	M10:30 M12:40	M12:40
Fuse-links bolts tightening torque	Nm	2	3.5	M5:3.5 M8:5	4	20	M10:30 M12:40	M10:30 M12:40	M12:40
Operating torque	Nm	3	5	7	7	19	38	38	65
Auxiliary contacts									
		OA4G_ ①	OA1/3G ②	OA_G_ ②	OA_G_ ②	OA_G_ ②	OA_G_ ②	OA_G_ ②	OA_G ②
Ratings according to IEC 947-5-1									
Rated voltage, U _i	VAC	690	690	690	690	690	690	690	690
Thermal current, I _{th}	A	10	16	16	16	16	16	16	16
AC12 / DC12, I _e	U _e =24V A	— / 6	—	—	—	—	—	—	—
	120V A	— / 6	—	—	—	—	—	—	—
	125V A	—	—	—	—	—	—	—	—
	230V A	—	6 / —	6 / —	6 / —	6 / —	—	6 / —	6 / —
	250V A	—	—	—	—	—	—	—	—
	400V A	—	4 / —	4 / —	4 / —	4 / —	—	4 / —	4 / —
	415V A	—	—	—	—	—	—	—	—
	440V A	2 / —	—	—	—	—	—	—	—
	480V A	—	—	—	—	—	—	—	—
	500V A	—	—	—	—	—	—	—	—
	600V A	—	—	—	—	—	—	—	—
	690V A	—	2 / —	2 / —	2 / —	2 / —	2 / —	2 / —	2 / —

① AC15 / DC12, according to IEC 947-5-1

② AC15, according to IEC 947-5-1

③ Values shown are corresponding max. allowed cut-off current, peak-values per single phase fuse tests.