

FUHGX | OXFORD™

AGRICULTURAL UNIT HEATER



THE PREMIER CHOICE FOR AGRICULTURE

The FUHGX is specially designed to meet the needs of agricultural buildings, such as henhouses, stables, barns and dairies. It's built to last thanks to its satincoat finish, resistant to humidity and corrosion. The FUHGX's low density element assures heating power without over-heating. In addition, its motor is sealed and lubricated for life, making it maintenance-free. With manual thermal protection and a fan switch for fan use only, it's the ultimate in efficiency and safety for farms and other agricultural settings.

SPECIALLY DESIGNED TO MEET THE NEEDS OF AGRICULTURAL BUILDINGS

HUMIDITY AND CORROSION RESISTANT SATINCOAT FINISH CABINET

LOW DENSITY ELEMENT MAINTAINS A LOWER CABINET TEMPERATURE

BALL-BEARING MOTOR SEALED AND LUBRICATED FOR LIFE

MANUAL THERMAL PROTECTION WITH PILOT LIGHT

FAN SWITCH FOR FAN USE ONLY

IDEAL FOR:

agricultural building, dairy, barn, cow shed, stable, henhouse, category 1 and 2 spaces (where hazardous vapors, liquid or excessive humidity are present – article 22-002 of the Canadian Electrical Code)

COLOUR

- charcoal

FINISH

- satincoat steel cabinet, coated with a high-quality epoxy powder paint making it 10 times more resistant to corrosion

MANUFACTURING

- robust, 18-gauge satincoat steel cabinet
- five adjustable louvers and safety wire mesh
- accessible thermal protection with manual reset
- pilot light indicates when thermal protection has been activated
- easy access junction box
- holes on the bottom eliminate humidity accumulation inside the unit

MOTOR

- lubricated for life and totally enclosed ball-bearing motor

ELEMENT

- nickel-plated and sealed with silicone to prevent corrosion
- low density element helps to keep cabinet temperature lower than that of a conventional heater

FAN

- fan switch allows the unit to operate as a fan only
- fan delay allows the unit to cool down before shutting off

CONTROL

- double pole built-in thermostat (included)

INSTALLATION

- wall or ceiling with universal mounting bracket (included)

WARRANTY

- three years

°STELPRO

°STELPRO reserves the right to modify descriptions, manufacturing specifications or prices without prior notice. No returns accepted on optional-colour products. For all the latest models and prices, please refer to our website at www.stelpro.com.



FC_FUHGX_EN_051018



TECHNICAL SPECIFICATIONS

PRODUCT	POWER		VOLTAGE	THROW DISTANCE		HEAT RISE		WEIGHT		PRICE
CODE	WATTS	BTU/H	VOLTS	M	FT.	°C	°F	KG	LB	
FUHGX5TCHAR	5000/3750	17 065/12 798	240/208	6.1	20	40	72	18	40	1304.00

TECHNICAL DRAWINGS

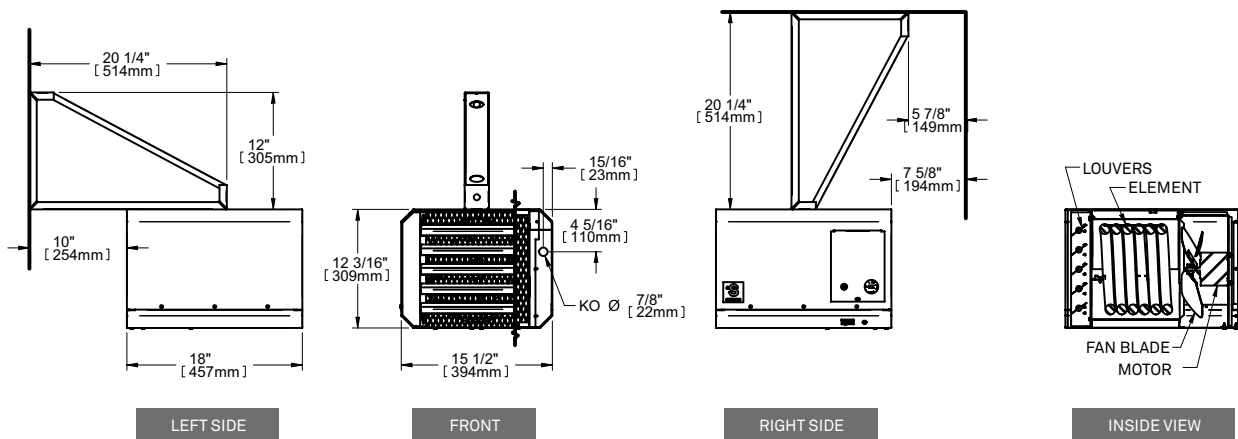

*STELPRO reserves the right to modify descriptions, manufacturing specifications or prices without prior notice. No returns accepted on optional-colour products. For all the latest models and prices, please refer to our website at www.stelpro.com.