

Day-Brite



by Signify

Linear

FluxStream EZ LED strip

4' and 8'



Day-Brite / CFI FluxStream EZ LED Strip is a high performing luminaire delivering smooth diffuse light ideal for light industrial, commercial and residential applications with unparalleled energy efficiency.

Project: _____
 Location: _____
 Cat.No: _____
 Type: _____
 Lumens: _____ Qty: _____
 Notes: _____

Ordering guide

Example: FSSEZ440L840-UNV-DIM

Series	Length (nominal)	Lumens ¹ (nominal)	Color temp. (K)	Voltage	Driver	Options
FSSEZ			-	UNV -	DIM	
FSSEZ FluxStream strip EZ	4' 4' length	40L 4000 lumens	830 80 CRI, 3000K 835 80 CRI, 3500K 840 80 CRI, 4000K 850 80 CRI, 5000K	UNV Universal voltage 120-277	DIM 0-10V Dimming	EMLED ³ Factory wired Bodine BSL310LP integral emergency pack. Nominal 1100 lm
	8' 8' length	80L 8000 lumens				LSXR10 120-347V motion sensor, factory installed on end cap

Footnotes

- Nominal delivered lumens at 25°C ambient.
- 8' is tandem (2) 4' lenses with single piece 8' body.
- EMLED on 8' model illuminates 4' section in emergency mode.
- Failure to properly select the "BAC" suffix could result in you receiving product that is not BAA compliant product with no recourse for an RMA or refund. This BAC designation hereunder does not address (i) the applicability of, or availability of a waiver under, the Trade Agreements Act, or (ii) the "Buy America" domestic content requirements imposed on states, localities, and other non-federal entities as a condition of receiving funds administered by the Department of Transportation or other federal agencies.
- Consult Signify to confirm whether specific accessories are BAA-compliant.

Accessories⁵ (order separately)

- FSSD4L - 4' Diffuse replacement lens
 - LSXR10 - Low bay PIR motion sensor, 120-277V
 - FSSWG4 - 4' Wire guard (order two for 8' model)
 - FSTH - Sliding hanger bracket (set of 2)
- (See last page for details and more options)

General notes

Many luminaire components, such as reflectors, refractors, lenses, sockets, lampholders, and LEDs are made from various types of plastics which can be adversely affected by airborne contaminants. If sulfur based chemicals, petroleum based products, cleaning solutions, or other contaminants are expected in the intended area of use, consult factory for compatibility.

PAF (Paint after fabrication) option is required for all products that will be used in a damp or humid location, such as under a canopy or covered parking area.



FSSEZ FluxStream strip EZ LED

4' and 8'

Features

- Compact design for installation in tight spaces
- Frosted acrylic diffuser provides wide light distribution and superior glare control
- Diffuser and LED plate snap into place allowing tool-free access to LED boards and driver
- Up to 50,000 hour predicted L70 LED lumen maintenance provides long service life to reduce maintenance costs
- Can be surface mounted on ceilings or walls, or suspended via chain, pendants or cables
- Wall mountable - ADA compliant
- Ideal for cold applications (-20°C)
- Continuous row mounting using standard end caps. No extra parts needed
- 7/8" knock out provided at each end and on base of luminaire. Note: Center knockout is covered and not useable in 4' version with EMLED option.

- 8' tandem unit is two 4' optical assemblies with a center mullion on a single full length chassis.
- Enclosed lens minimizes penetration of dust, insects, and other debris into the LED compartment.
- Fluxstream luminaires are Designlights Consortium® qualified. Please see the DLC QPL list for exact catalog numbers (<http://www.designlights.org/QPL>).
- 5 year manufacturer's limited warranty Visit www.philips.com/warranties for complete warranty information.

Finish

- Baked white acrylic matte high reflectance paint finish
- PAF (Paint after fabrication) option, which is required for all products that will be used in damp or humid locations, such as a canopy or covered parking area, provides extra corrosion resistance.

Shielding

- Contoured frosted acrylic lens

Electrical

- LED boards and drivers are RoHS (Restriction of Hazardous Substances) compliant. Total system life rated at 50,000 hours. Predicted L70 lifetime based on LED manufacturer's supplied LM-80 data and in-situ laboratory testing.

Materials

- Heavy gauge cold rolled steel housing and end caps

Labels

- cETLus listed (-20°C to 25°C)
- Suitable for damp locations

Performance data

Fixture	Lumens	Wattage	Efficacy
FSSEZ440L840	4130lm	31W	133lm/w
FSSEZ880L840	8260lm	62W	133lm/w

Dimensions

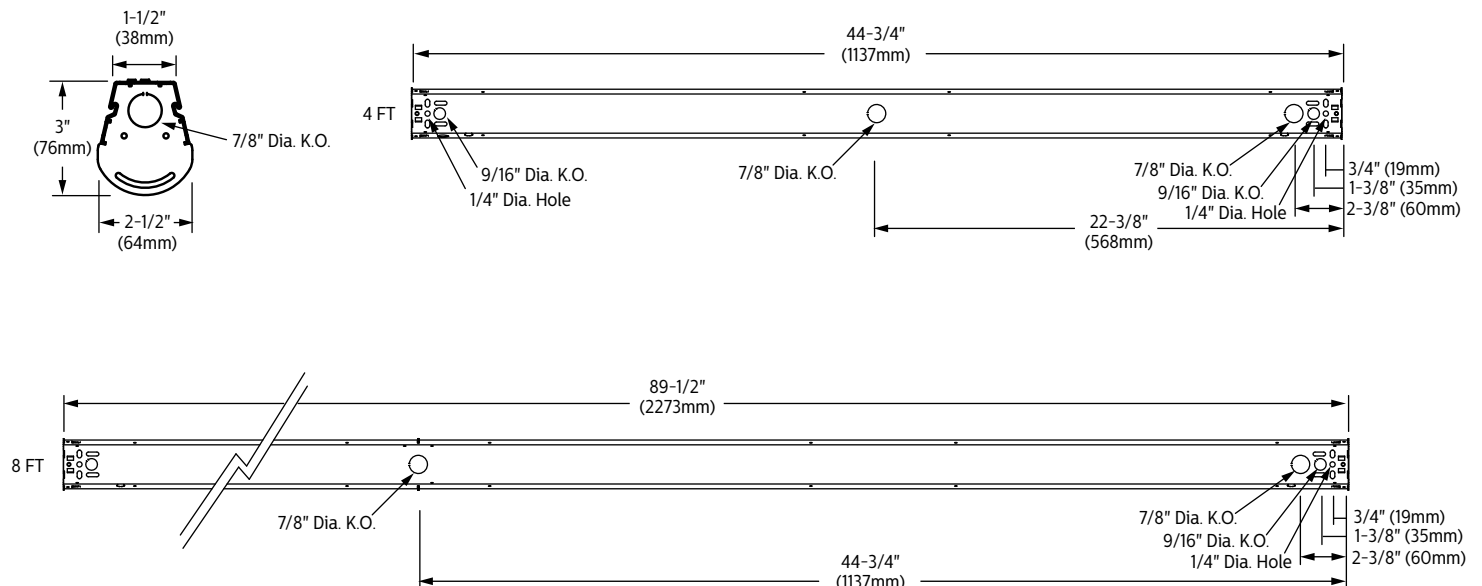

FSSEZ FluxStream strip EZ LED

4' and 8'

Photometry

FSSEZ440L840-UNV

Luminaire Lumens	4130
Luminaire Efficacy Rating (LER)	133
Total Luminaire Watts	31
Spacing Criterion (0-180)	1.3

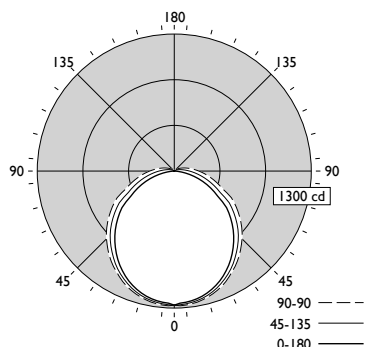

Candela Distribution					
	End	45	Cross	90	
0	1050	1050	1050	1050	
5	1031	1045	1053	1045	
15	989	1010	1025	1010	
25	904	938	967	938	
35	786	837	881	837	
45	647	726	782	726	
55	493	587	667	587	
65	309	421	545	421	
75	155	303	398	303	
85	29	204	298	204	

Zonal Lumen Summary		
Zone	Lumens	%Luminaire
0-30	817	22.4
0-40	1341	36.7
0-60	2416	66.1
0-90	3357	91.9
90-180	296	8.1
0-180	3653	100

Avg. Luminance (cd/m ²)			
	0	45	Cross
45	13707	11958	11915
55	12754	10817	11115
65	10675	9122	10361
75	8488	8267	9143
85	4081	7810	8995

Coefficients of Utilization %								
Pc---	80			70			50	
Pw---	70	50	30	70	50	30	50	30
RCR								
0	117	117	117	113	113	113	107	107
1	105	98	93	101	95	92	91	86
2	94	85	78	91	82	76	78	72
3	85	75	66	82	72	65	68	61
4	79	66	56	76	64	56	60	53
5	71	58	48	68	56	47	54	46
6	67	53	44	64	51	42	48	40
7	61	47	39	58	46	38	44	36
8	56	44	34	55	41	34	40	33
9	54	40	32	52	39	30	36	29
10	50	37	29	48	36	28	34	27

Accessories⁵



Accessory Catalog Code	Description	
FSTH	Sliding hanger bracket (pair)	
SV5F12	12" Stem and canopy kit	White stem and canopy kit, 1/4" trade size (1/2" O.D.) locknuts included. Works with 9/16" k.O. on base of housing.
SV5F18	18" Stem and canopy kit	
SV5F24	24" Stem and canopy kit	
SV5F36	36" Stem and canopy kit	
SV5F48	48" Stem and canopy kit	
FKR-126	Chain hanger set (pair)	Includes two 5' heavy duty link chains with "V" hooks. Attaches to base of housing.
DACHxx	Adjustable cable hanger kit (single)	Works with 1/4" hole on base of housing or FSTH hanger bracket. xx=cable length in inches, enter 48" to 180" lengths in 12" increments
DACHxx-1-SC	Adjustable cable hanger kit with white straight 18/3 cord (single)	
DACHxx-1-CC	Adjustable cable hanger kit with white coiled 18/3 cord (single)	
DACHxx-2-SC	Adjustable cable hanger kit with white straight 18/4 cord (single)	
DACHxx-2-CC	Adjustable cable hanger kit with white coiled 18/4 cord (single)	
DACHxx-1D-SC	Adjustable cable hanger kit with white straight 18/5 cord with dimming leads (single)	
LSXR10	Low bay pir motion sensor (120-277v)	
FSSWG4	4' Wire guard (order two for 8' models)	
FSSD4L	4' Diffuse replacement lens	

⁵ Consult Signify to confirm whether specific accessories are BAA-compliant.



© 2021 Signify Holding. All rights reserved. The information provided herein is subject to change, without notice. Signify does not give any representation or warranty as to the accuracy or completeness of the information included herein and shall not be liable for any action in reliance thereon. The information presented in this document is not intended as any commercial offer and does not form part of any quotation or contract, unless otherwise agreed by Signify.

Signify North America Corporation
200 Franklin Square Drive,
Somerset, NJ 08873
Telephone 855-486-2216

Signify Canada Ltd.
281 Hillmount Road,
Markham, ON, Canada L6C 2S3
Telephone 800-668-9008

All trademarks are owned by Signify Holding or their respective owners.